

2008 Bobcat T180 Compact Track Loader Service Repair Workshop Manual  
531411001-531511001



# S220

**TURBO**

# S220

**TURBO**

**HIGH FLOW**



# Bobcat®

## Service Manual

S/N 526211001 & Above  
S/N 526311001 & Above

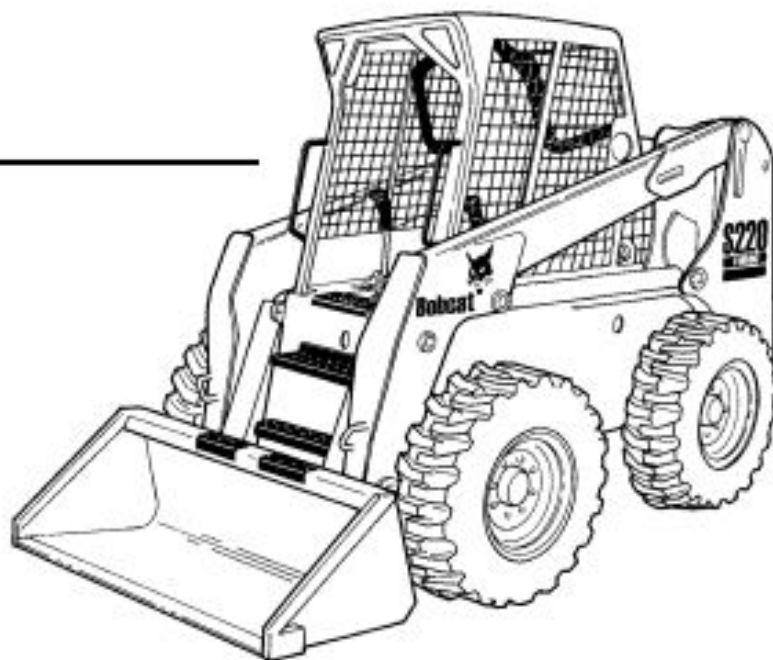

EQUIPPED WITH  
BOBCAT INTERLOCK  
CONTROL SYSTEM (BICS™)

6902722 (2-06)

1 of 1074

**IR** Ingersoll Rand  
Company Vehicle Technologies  
Printed in U.S.A.

© Bobcat Company 2006

Dealer Copy - Not for Resale

## BOBCAT LOADER IDENTIFICATION

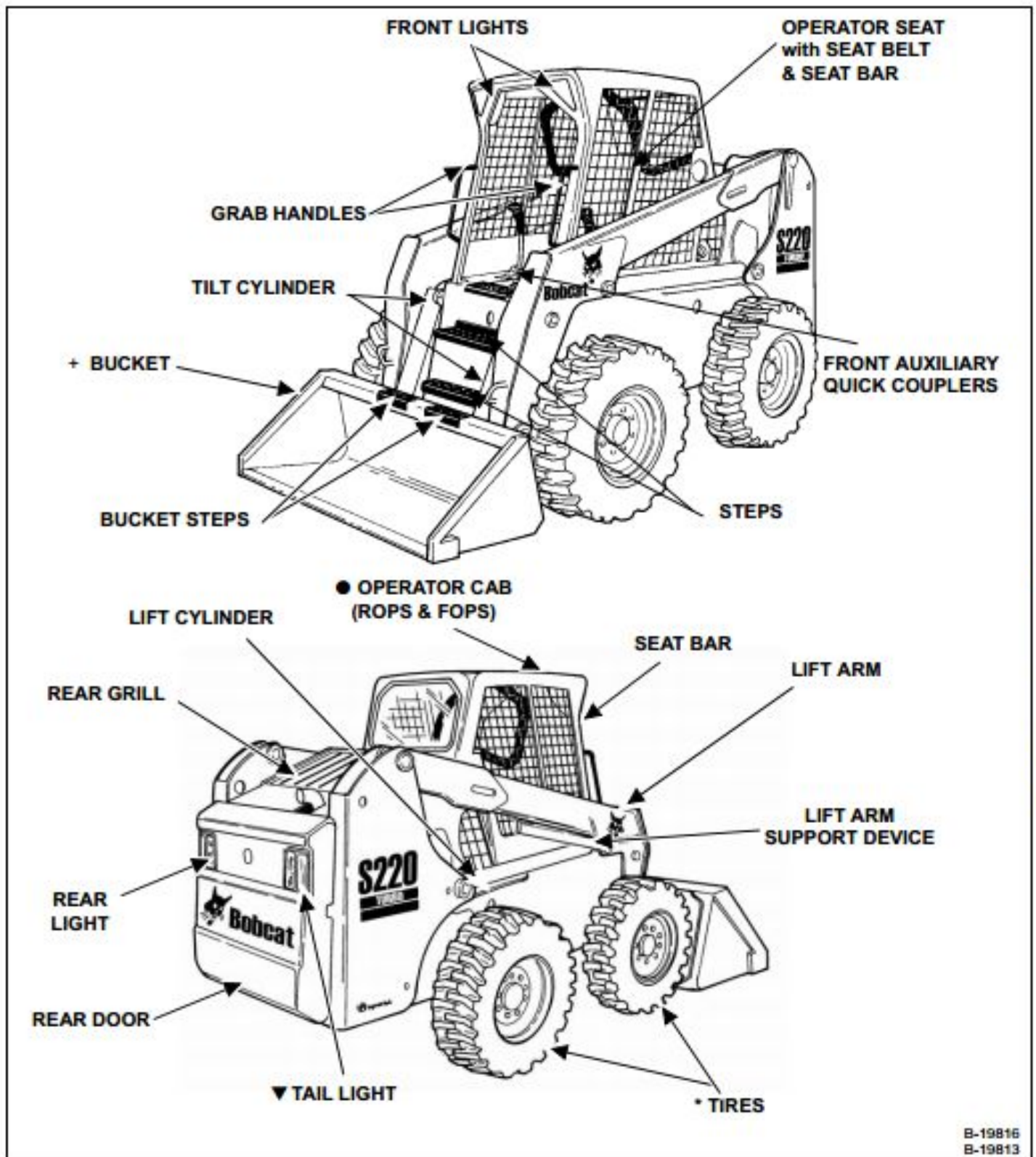

Dealer Copy -- Not for Resale

B-19816  
B-19813

▼ OPTIONAL OR FIELD ACCESSORY (Not Standard Equipment)

\* TIRES - Flotation tires ▼ are shown. The Bobcat loader is factory equipped with standard tires.

+ BUCKET - Several different buckets and other attachments are available for the Bobcat loader.

● ROPS, FOPS - Roll Over Protective Structure, per SAE J1040 and ISO 3471, and Falling Object Protective Structure per SAEJ1043 and ISO 3449, Level I. Level II is available. The Bobcat loader is base-equipped with a standard operator cab as shown. Extra insulated cab is available as an option (Reduced noise level).

## AIR CLEANER SERVICE

### Replacing Filter Element

Figure 10-80-1

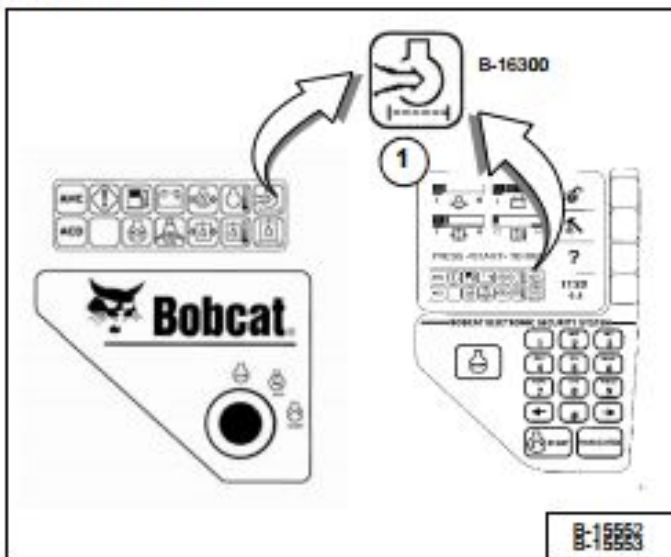

It is important to change the air filter element only when the Air Cleaner Icon in the right panel is ON (Item 1) [Figure 10-80-1] and you hear three beeps from the alarm.

Replace the inner filter every third time the outer filter is replaced or as indicated on See Replacing Filter Element (Cont'd) on Page 10-80-2.

Figure 10-80-2

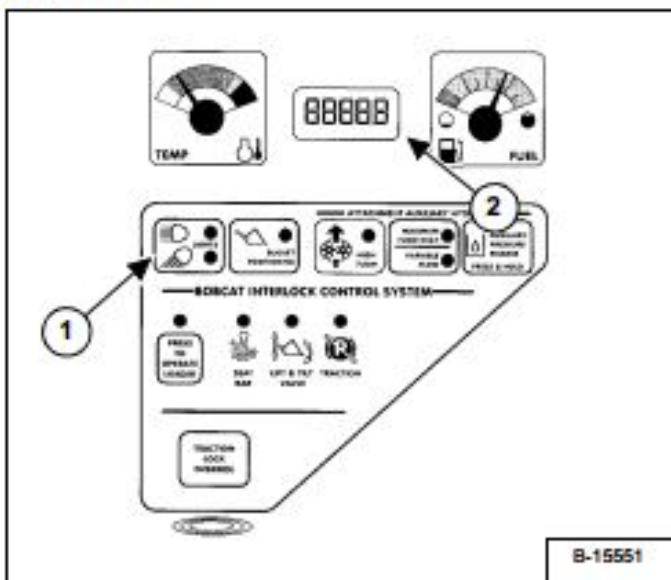

Press and hold the LIGHT Button (Item 1) [Figure 10-80-2] for two seconds.

If the filter element needs replacement, the CODE [01-17] (Air Filter Plugged) will show in the HOURMETER / CODE DISPLAY (Item 2) [Figure 10-80-2].

Figure 10-80-3



### OUTER FILTER

Disengage the wing nut (Item 1) [Figure 10-80-3] and remove the dust cover.

Figure 10-80-4

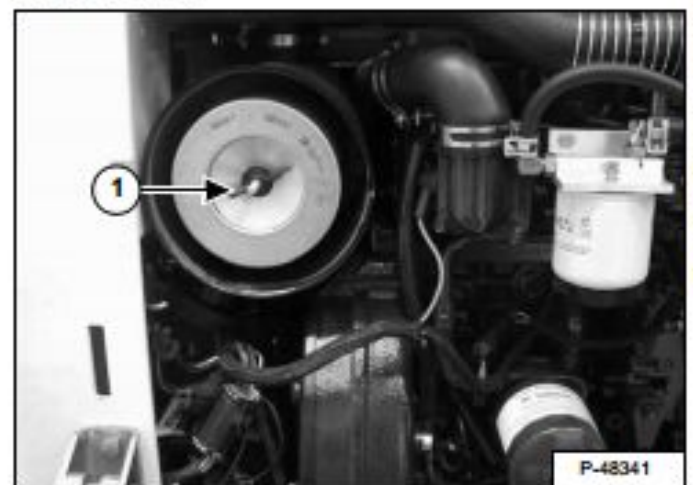

Remove the wing nut (Item 1) [Figure 10-80-4] and remove the outer filter element.

**NOTE:** Make sure all sealing surfaces are free of dirt and debris.

Install a new outer element, and install the wing nut.

Install the dust cover and install the outer wing nut.

Check the air intake hose and the air cleaner housing for damage. Make sure all connections are tight.

Dealer Copy -- Not for Resale



Thank you very much  
for your reading.  
Please click here  
to get more information.