

# JCB 506C,506CHL,508C Loadalls Telescopic Handler Service Repair Manual





# Service Manual

## JZ 70

From machine no.834000

PUBLISHED BY THE  
TECHNICAL PUBLICATIONS DEPARTMENT  
OF JCB SERVICE: ©  
CHEADLE ROAD, UTTOXETER  
STAFFORDSHIRE, ST14 7BS,  
ENGLAND

Tel. (01889) 590312  
PRINTED IN ENGLAND

Publication No. 9803/6030  
Issue 0

<b>General Information</b>	<b>1</b>
<b>Care &amp; Safety</b>	<b>2</b>
<b>Routine Maintenance</b>	<b>3</b>
<b>Attachments</b>	<b>A</b>
<b>Body &amp; Framework</b>	<b>B</b>
<b>Electrics</b>	<b>C</b>
<b>Controls</b>	<b>D</b>
<b>Hydraulics</b>	<b>E</b>
<b>Transmission</b>	<b>F</b>
<b>Track &amp; Running Gear</b>	<b>J</b>
<b>Engine</b>	<b>K</b>

You must grease the machine regularly to keep it working efficiently. Regular greasing will also lengthen the machine's working life.

Greasing should be done with a grease gun. Normally, two strokes of the gun should be enough. Stop greasing when fresh grease appears at the joint.

For the type of grease to use at each point, see Fluids and Lubricants - Capacities and Specifications.

Do not mix different types of grease. Keep them separate.

### **⚠ WARNING**

You will be working close into the machine for these jobs. Lower the attachments if possible. Remove starter key and disconnect the battery. This will prevent the engine being started.

4-2-1-3

## Slew Ring Teeth and Slew Pinion

Ensure slew ring is kept full of grease. Always grease whenever the machine has been steam-cleaned.

For location of the slew ring gear refer to Component Locations at the end of this section.

### 1 Make the Machine Safe

Stop the engine and remove the starter key.

### 2 Grease the Slew Ring

- a Remove cover A and discharge port plug B.
- b Apply grease to the slew ring via aperture C.

### 3 Slew the Machine

Start the engine and slew the machine a few degrees. Stop the engine, remove the starter key and apply grease again.

Repeat until the whole ring is greased. Check that grease exudes around the entire circumference.

### 4 Refit the Cover

Refit discharge port plug B and cover A.

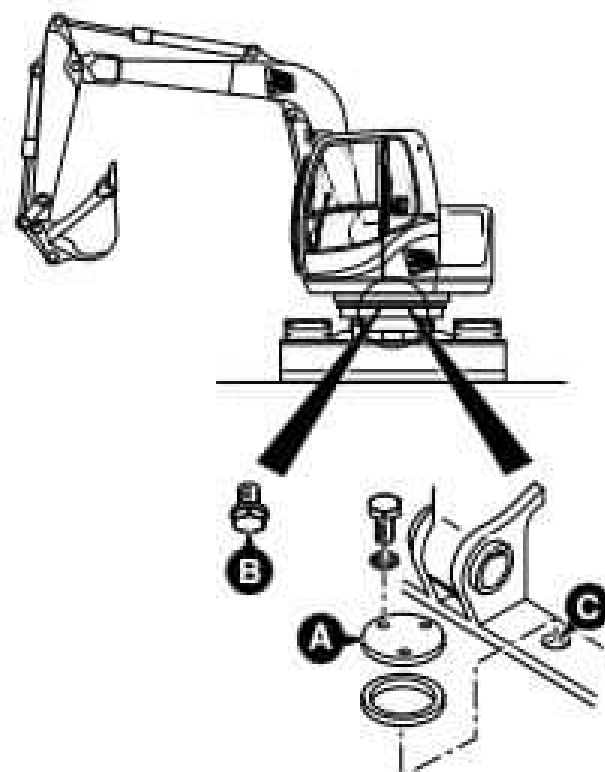

J508211

## Slew Ring Bearing

Three grease nipples are mounted on the slew ring D



A363230

## Checking the Coolant Level

### 1 Park the Machine on Level Ground

Stop the engine and let it cool down. Open the engine compartment.

#### WARNING

The cooling system is pressurised when the coolant is hot. Hot coolant will burn you. Make sure that the engine is cool before checking the coolant level or draining the system.

2-3-33

### 2 Release System Pressure

For location of engine cooling radiator, refer to **Component Locations** at the end of this section.

Carefully slacken cap **A**. Let any pressure escape. Remove the cap.

### 3 Check the Level

The level should be between the **FULL** and **LOW** marks on the expansion bottle **B**. Top up the bottle with pre-mixed water/antifreeze if necessary. See **Coolant Mixtures**.

### 4 Refit the Pressure Cap A

Make sure it is tight.

**Note:** Check the quality of the antifreeze mixture every year - before the cold weather starts. Change it every two years.

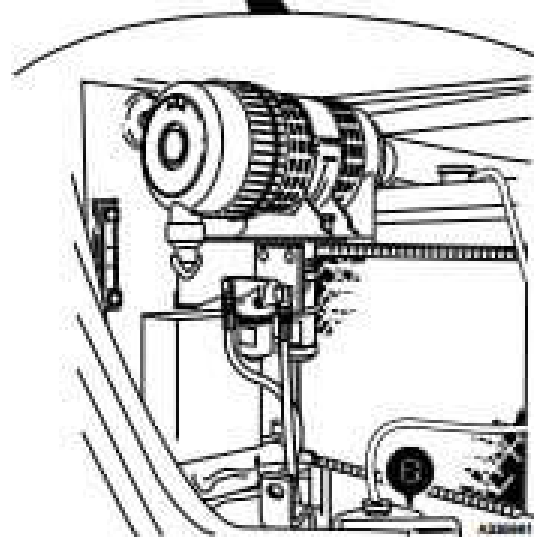
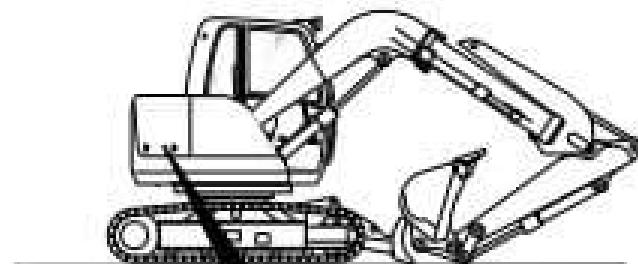
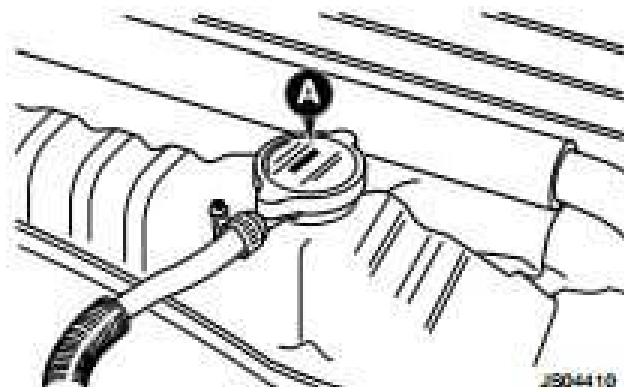

## Coolant Mixtures

To prevent the coolant freezing in cold conditions, antifreeze must be added. JCB Four Seasons Antifreeze and Summer Coolant will give protection down to the temperatures shown in the table.

Antifreeze Solution	Starts to freeze at
55%	-38 °C (-33 °F)

Never use less than a 50% solution otherwise there will not be enough corrosion protection.

Never use more than 60% solution otherwise the cooling system may be damaged.

Leave the antifreeze in all the year round as it gives protection against corrosion.

Check the strength of antifreeze solution at least once a year, preferably at the start of the cold period. Always renew the antifreeze every two years.

A 50% antifreeze mixture should be used even if frost protection is not needed. This gives protection against corrosion and raises the coolant's boiling point.



Thank you very much  
for your reading.  
Please click here  
to get more information.