

JCB 801 Tracked Excavator Service Repair Manual



PDF



DOWNLOAD



VMT860 Tier 3

Service Manual - VMT860 Tier 3

[Section 1 - General Information](#)

[Section 2 - Care and Safety](#)

[Section 3 - Maintenance](#)

[Section C - Electrics](#)

[Section E - Hydraulics](#)

[Section H - Steering](#)

[Section K - Engine](#)

[Section L - Vibration](#)



Publication No.
9813/0150-1



Copyright © 2001 JCB SERVICE. All rights reserved. No part of this publication may be reproduced, stored in a retrieval system, or transmitted in any form or by any other means, electronic, mechanical, photocopying or otherwise, without prior permission from JCB SERVICE.

Issued by JCB Technical Publications, JCB Aftermarket Training, Walsley, Rotherham, South Yorkshire, S71 10W, England. Tel: +44 (0)1909 891300 Fax: +44 (0)1909 891300

World Class
Customer Support

Changing the Oil and Filter

13-222-2

Drain the oil when the engine is warm as contaminants held in suspension will then be drained with the oil.

- 1 Get access to the engine. Refer to *Access Panels, Engine Cover*.
- 2 Place a container of suitable size beneath the sump drain plug C.

CAUTION

Oil will gush from the hole when the drain plug is removed. Hot oil and engine components can burn you. Keep to one side when you remove the plug.

13-3-1-15

- 3 Drain the engine oil.
 - a Machines with a sump plug, remove the sump drain plug C and its 'O' ring D. Let the oil drain out, then clean and refit the drain plug with a new 'O' ring. Torque the drain plug to 40-60Nm (30-44lbf ft).
 - b Machines with a drain valve, remove the dust cap K from the sump drain port. Attach drain tube L. With the free end of the tube in an oil container, screw in the drain tube assembly to open the valve.

When all the oil has drained, unscrew the drain tube assembly and fit the dust cap K.

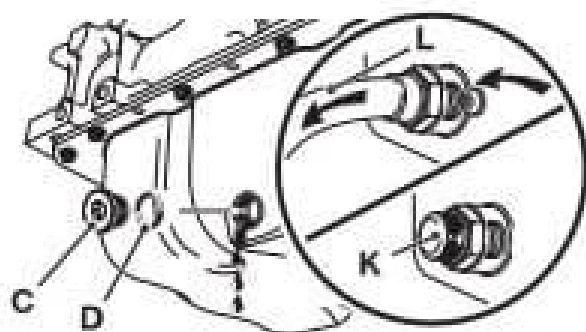

Fig 6.

020119-1

- 4 Place a container of suitable size under drain plug E to catch the oil. [➔ Fig 7. \(D 3-31\).](#)

- 5 Loosen and remove the filter housing drain plug E and its 'O' ring J. Let the oil fully drain, then clean and refit the drain plug with a new 'O' ring. Torque the drain plug to 40-60Nm (30-44lbf ft).
- 6 Unscrew the filter canister F, use a chain wrench if necessary.
- 7 Clean the seal face of the filter head G.
- 8 Smear the seal H on the new filter canister F with clean engine oil.
- 9 Screw the filter on until it just contacts the filter head.
- 10 Turn the filter at least a further 3/4 of a turn.
- 11 Through the top filler point, fill the engine with the recommended oil to the MAX mark on the dipstick. Refer to *Checking the Oil Level*. Wipe off any spill oil, refit the filler cap and make sure it is secure.
- 12 Operate the engine until the oil pressure low warning light has extinguished. Check for oil leakage. When the oil has cooled, check the oil level again, and if necessary top up with clean engine oil.

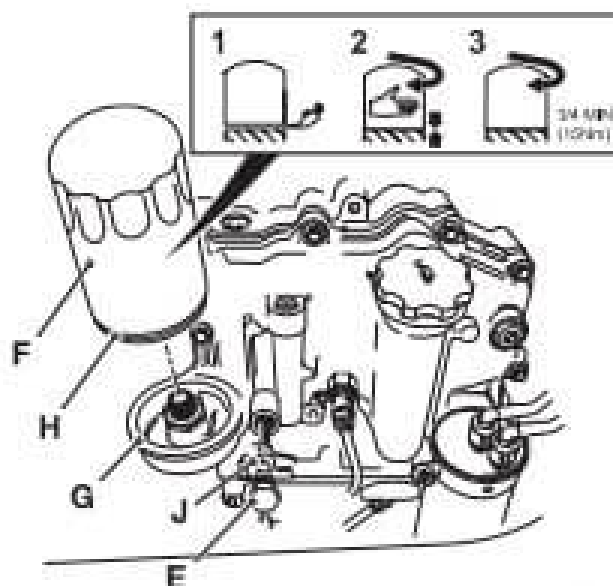

Fig 7.

020119-6

Cooling System

Checking the Coolant Level

⚠ WARNING

The cooling system is pressurised when the coolant is hot. When you remove the cap, hot coolant can spray out and burn you. Make sure that the engine is cool before you work on the cooling system.

9-3-3-1_2

Visually check the coolant level daily, do not depend on the coolant level indicator to illuminate before adding coolant.

Note: Check the quality of the antifreeze mixture every year, before the cold weather starts. Change it every two years.

The engine coolant over flow tank is located behind the right engine cover ➔ [Fig 8. \(D 3-32\)](#).

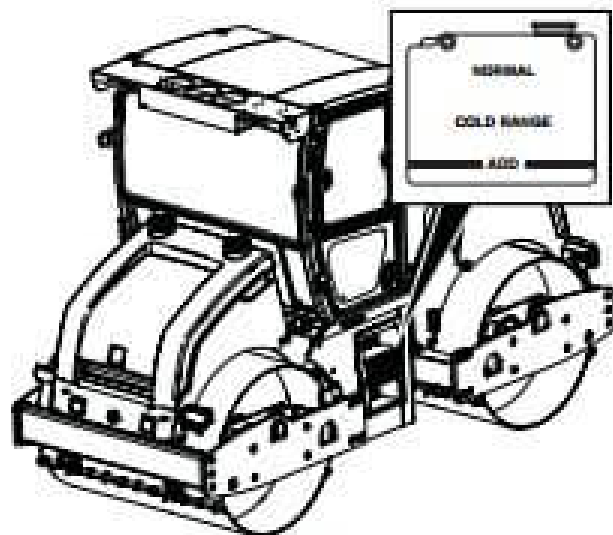

Fig 8.

- 1 Park the machine on firm level ground. ➔ [Stopping and Parking the Machine \(D 1-47\)](#).
- 2 Switch off the engine and remove the ignition key.
- 3 The coolant level should be between the 'cold range' and 'normal' marks on the coolant over flow tank.
- 4 If the coolant level is low:

- a Carefully loosen cap on the coolant reservoir. Let any pressure escape before removing the cap. Fill with pre-mixed water/antifreeze until it reaches the correct level.

Important: Allow the engine to cool before removing the cap on the coolant reservoir.

Important: Do not exceed the 'normal' mark.

- b Fit the cap.
- c Run the engine for a while to raise the coolant to working temperature and pressure. Stop the engine and check for leaks.



Thank you very much
for your reading.
Please click here
to get more information.