



**PDF**  **DOWNLOAD** 



# A3-1 CARRIAGE AND FORKS



ITEM PART

1 150/

547/

547/

1A 547/

# Bucket Ram Pivot and Linkage

## Removal and Replacement

### Removal

- 1 Remove the bucket. See Section J, *Routine Maintenance*.
- 2 Remove the self-locking nut C and the bolt D. Support the link H. Drive out the pivot pin E and remove the link H. Lower the piston rod end of the bucket ram F clear of the link G.
- 3 Clean all old grease from the links G and H and pivot pin E.

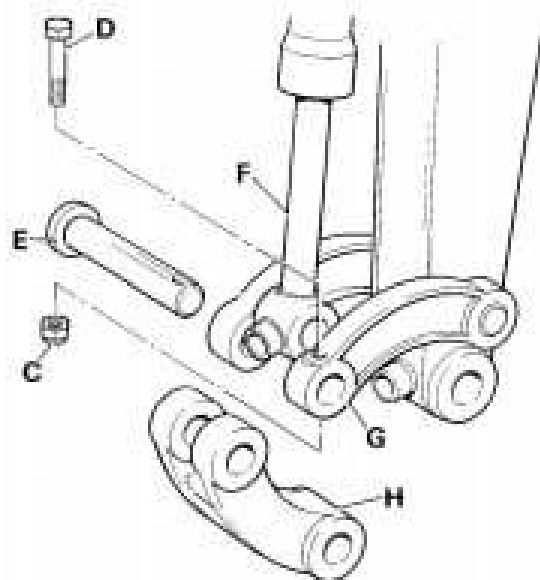

A395420

Fig 1.

### Inspection

- 1 Check that the link bushes and the pivot pin are within permitted tolerances. Renew pivot pin and/or remove and replace link bushes as necessary.

Table 1. Tolerances

	Pivot pin	Pivot bush
Reference value	30 mm dia.	30 mm ID
Allowable limit	29 mm dia.	31 mm ID

### Replacement

#### **⚠ WARNING**

Do not use your fingers through the holes to align the links.

8-2-9-32

- 1 Locate the fork end of the link H into the fork of the dipper end link G. Locate the rod end of the bucket ram F into the fork of the link H.
- 2 Fit the pivot pin E through both links and the ram end. Secure using bolt D and new self-locking nut C.
- 3 Grease the linkage through the grease nipple on the ram end boss, for grease specification and quantity. See Section 3, *Greasing*.

## Operation

The pressure reduction unit comprises spools 26, pressure control springs 18, return springs 13 and spring seats 17. The spools 26 are held against the plungers 16 by the return springs 13.

The lower end of the main body 21 contains the main inlet port P fed from the pump, exhaust port T connected to tank and the pilot pressure outlet ports 1, 2, 3 and 4.

The pilot pressure controls the stroke and direction of the main control valve spools.

Oil supplied by the hydraulic pilot pump enters at port P and the function of the spools 16 is to direct oil from the inlet port P to the output ports 1, 2, 3 and 4 or alternatively, to the exhaust port T to tank. The pressure control springs 18 act on the spools 26 to determine pressure at each port. Plungers 16 slide in the guides 15 to vary the compression in the springs 18. The control handle, fixed to the adjusting nut 10 and circular rocker plate 11 is operated to move the plungers 16. The control handle is able to rotate 360° around the knuckle joint 9.

The return springs 13 operate between the casing 21 and the seats 17, regardless of the outlet pilot pressure, returning the plungers 16 to their outer positions, ensuring the spools 26 return to their neutral (closed) positions. The springs 13 also provide a resistive force, giving the operator a 'tactile feel' of the controls.

The control handles contain electrical push button and rocker switches which are used to operate auxiliary services.

When the control handle is tilted, the plungers 16 move down, depressing the return spring seats 17, simultaneously compressing the pressure control springs 18, moving the spool, allowing hydraulic oil to flow to the designated pilot port.

If the handle is held in the tilted position, the pressure in the outlet ports rises to equal the force of pressure control spring 18; the oil pressure and spring force become balanced. If the outlet pressure exceeds the set pressure, the spool moves to allow port T to open. If the outlet pressure falls below the set pressure, port T is closed and port P is opened.

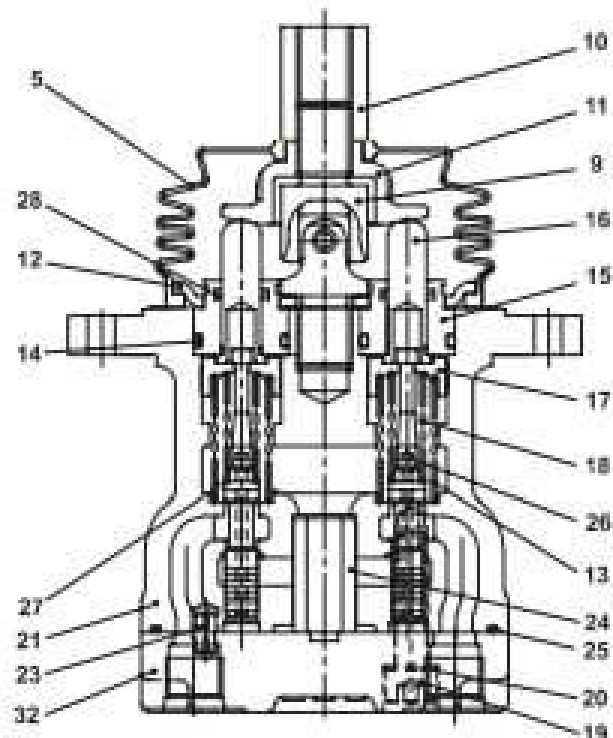
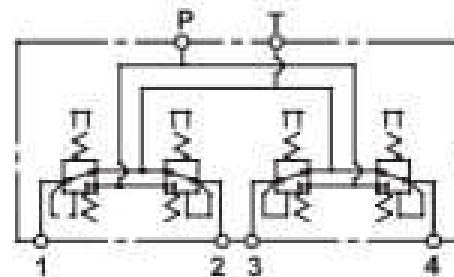

Fig 1.



Thank you very much  
for your reading.  
Please click here  
to get more information.