

Sprayer

50 Gallon



Bobcat®

**Operation
&
Maintenance
Manual** 

S/N 005900101 & Above

PDF



DOWNLOAD

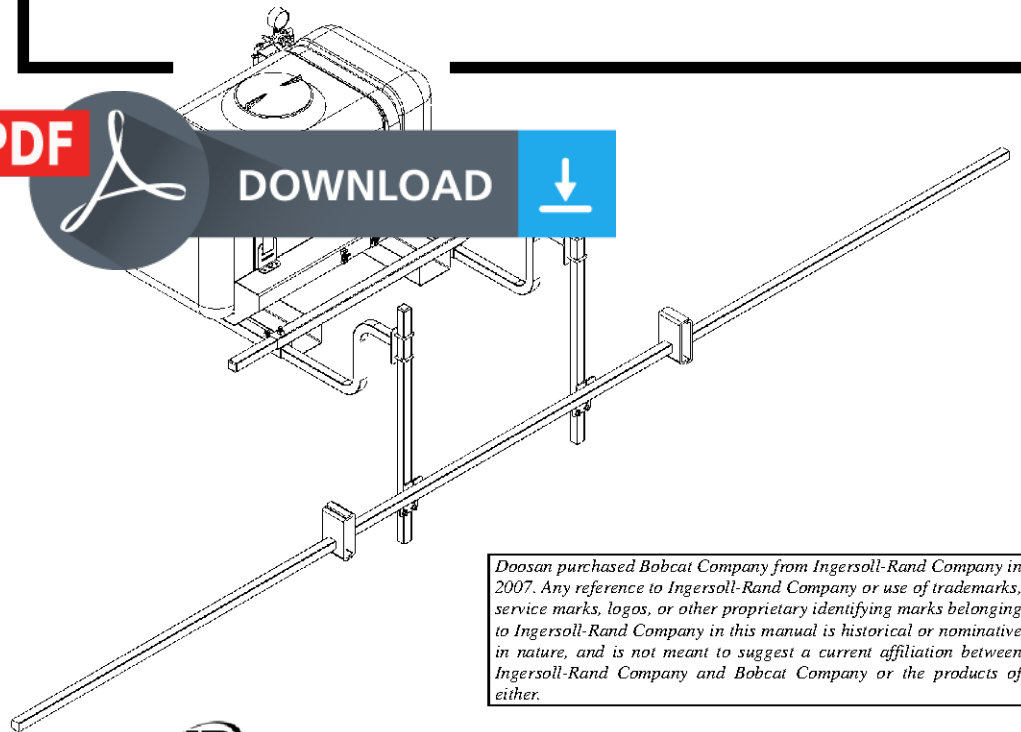

Doosan purchased Bobcat Company from Ingersoll-Rand Company in 2007. Any reference to Ingersoll-Rand Company or use of trademarks, service marks, logos, or other proprietary identifying marks belonging to Ingersoll-Rand Company in this manual is historical or nominative in nature, and is not meant to suggest a current affiliation between Ingersoll-Rand Company and Bobcat Company or the products of either.

An  **Ingersoll-Rand** business

CONTENTS

FOREWORD..... V
SAFETYIX
OPERATING INSTRUCTIONS..... OI-1
PREVENTIVE MAINTENANCE PM-1
SPECIFICATIONS SPEC-1

REFERENCE INFORMATION

Write the correct information for YOUR Sprayer Attachment in the spaces below.
Always use these numbers when referring to your Sprayer.

Sprayer Serial Number

NOTES:

YOUR BOBCAT® DEALER:

ADDRESS:

PHONE:

Bobcat Company
P.O. Box 128
Gwinner, ND 58040-0128

Bobcat Company Europe
J. Huysmanslaan 59
B-1651 LOT
Belgium

FOREWORD

SAFETY

OPERATING
INSTRUCTIONS

PREVENTIVE
MAINTENANCE

SPECIFICATIONS



Bobcat®

BOBCAT COMPANY IS ISO 9001:2000 CERTIFIED



ISO 9001:2000 is a set of international standards that control the processes and procedures which we use to design, develop, manufacture, distribute, and service Bobcat products.

British Standards Institute (**BSI**) is the Certified Registrar Bobcat chose to assess the Company's compliance with the ISO 9001:2000 set of standards. The BSI registration certifies that the two Bobcat manufacturing plants and the Bobcat corporate offices (Gwinner, Bismarck & West Fargo) in North Dakota are in compliance with ISO 9001:2000. Only certified assessors, Like BSI, can grant registrations. Continued certification is subject to periodic audits.

ISO 9001:2000 means that as a company we say what we do and do what we say. In other words, we have established procedures and policies, and we provide evidence that the procedures and policies are followed.



Thank you very much
for your reading.
Please click here
to get more information.