

# 2000-2002 Kawasaki ZX6R Motorcycle Service Repair Workshop Manual



**PDF**  **DOWNLOAD** 



**Kawasaki**

**Ninja ZX-6R**



**Motorcycle  
Service Manual**

# Quick Reference Guide

<b>General Information</b>	<b>1</b>
<b>Fuel System</b>	<b>2</b>
<b>Cooling System</b>	<b>3</b>
<b>Engine Top End</b>	<b>4</b>
<b>Clutch</b>	<b>5</b>
<b>Engine Lubrication System</b>	<b>6</b>
<b>Engine Removal/Installation</b>	<b>7</b>
<b>Crankshaft/Transmission</b>	<b>8</b>
<b>Wheels/Tires</b>	<b>9</b>
<b>Final Drive</b>	<b>10</b>
<b>Brakes</b>	<b>11</b>
<b>Suspension</b>	<b>12</b>
<b>Steering</b>	<b>13</b>
<b>Frame</b>	<b>14</b>
<b>Electrical System</b>	<b>15</b>
<b>Appendix</b>	<b>16</b>

This quick reference guide will assist you in locating a desired topic or procedure.

- Bend the pages back to match the black tab of the desired chapter number with the black tab on the edge at each table of contents page.
- Refer to the sectional table of contents for the exact pages to locate the specific topic required.

## 1-36 GENERAL INFORMATION

### Cable, Wire, and Hose Routing

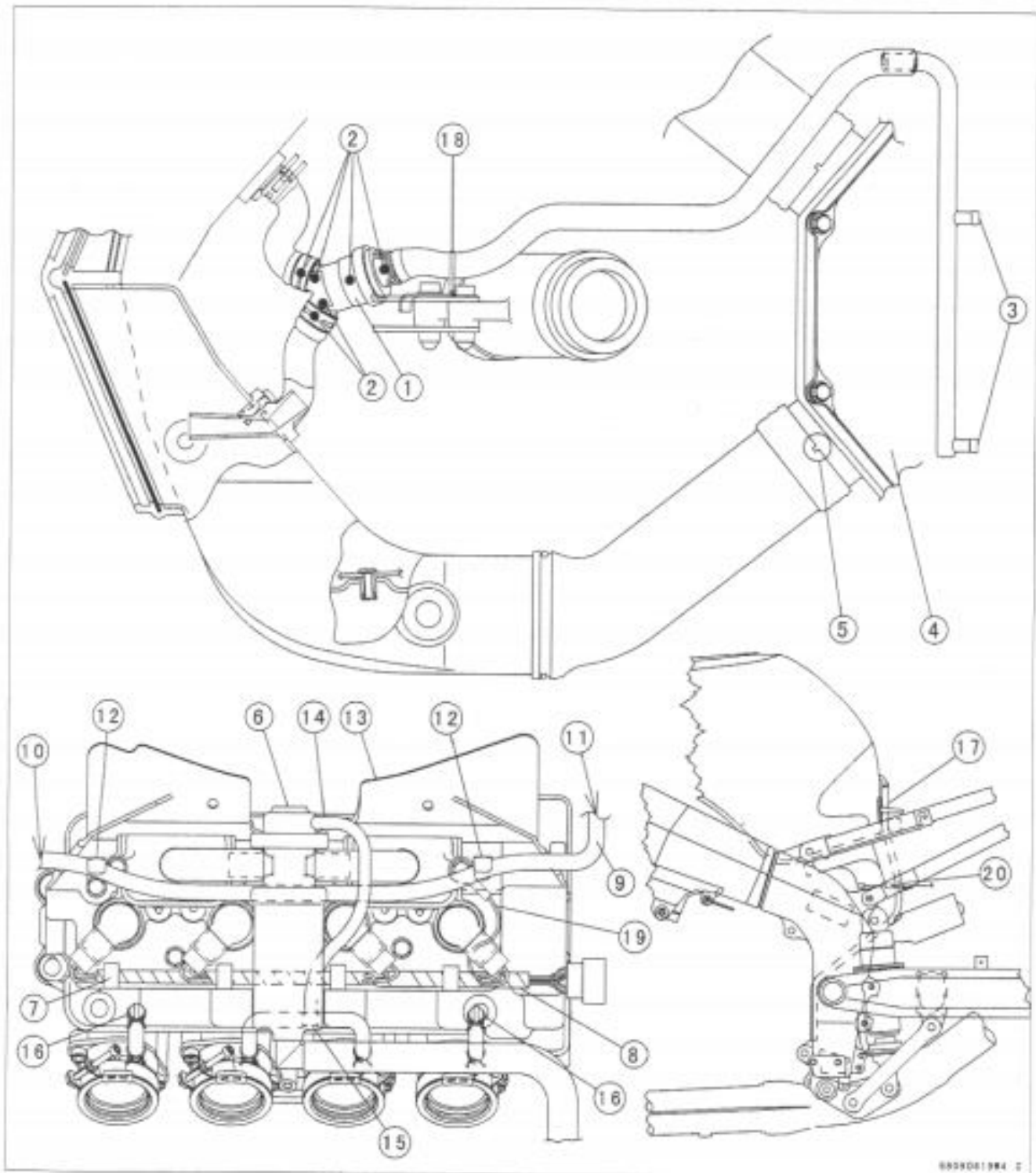

889001984 Z

1. Air Vent Filter
2. Align the mark on the hose with the mark on the filter
3. To Carburetors
4. Air Cleaner Housing
5. Fit the projection of the housing in the recess of the air duct.
6. Vacuum Switch Valve
7. Through the stick coil lead
8. Stick Coil Lead
9. Coolant Reserve Tank Hose
10. To Coolant Reserve Tank
11. To Radiator
12. Install the clamps with the baffle plate.
13. Baffle Plate
14. Vacuum Hose
15. Vacuum Hose Fitting
16. Plug
17. Fuel Tank Drain Hose
18. Clamp (Air Vent Filter Hose)
19. Cylinder Head Cover Ground Lead
20. Run the hose through the hole of the fender.

# 2000-2002 Kawasaki ZX6R Motorcycle Service Repair Workshop Manual

Instant download 2000-2002 Kawasaki ZX6R Motorcycle Service Repair Workshop Manual. This manual contains all service, repair, maintenance, troubleshooting procedures for Kawasaki Motorcycle Machine.

All major topics are covered step-by-step instruction, diagrams, illustration, wiring schematic, and specifications to repair and troubleshoot. With this factory service repair manual on hand can easily help you with any repairs that you may need for your Kawasaki Motorcycle Machine.

Machine model :

ZX6R

Manual Covers:

\*General Information

\*Fuel System(DFI)

\*Cooling System

\*Engine Top End

\*Clutch

\*Engine Lubrication System

\*Engine Removal/Installation

\*Crankcase/Transmission

\*Wheels/Tires

\*Final Drive

\*Brakes

\*Suspension

\*Steering

\*Frame

\*Electric System

\*Appendix

AND MORE...SPECIFICATION:

Pages:333

Format: PDF

Language: English

Compatible: Win/Mac All pages are printable, so run off what you need & take it with you into the garage or workshop.

Save money \$\$ by doing your own repairs! It makes it easy for any skill level with these very easy to follow, step-by-step instructions!

Instant download means no shipping cost or waiting for a CD to arrive in the mail...you will receive this manual today via instant download on completion of payment via our secure payment processor. We accept all major credit/debit cards/paypal.

Instant download! Thank you for visiting!



Thank you very much  
for your reading.  
Please click here  
to get more information.