

# John Deere 135D RTS Excavator Diagnostic, Operation and Test Service Manual (TM10742)

444K 4WD with Loader  
Engine 4045HDW54 (T3)  
(S.N. 642101—670307)  
Diagnostic



## OPERATION AND TEST MANUAL

4WD Loaders with Engines 4045HDW54 (T3) models 444K ( PIN:  
1DW444KZ\*\*D642101-670307)

TM12090 22 FEB 16 (ENGLISH)

**For complete service information also see:**

444K 4WD Loader (SN. 642101-670307) Repair

TM12092

JDLink (MTG) Technical Manual

TM114519

PowerTech E 4.5 and 6.8L Diesel Engines with 16 Electronic Fuel System With  
Denso HPCR

CTM502

120 Series Hydraulic

120 Series Hydraulic

125 Series Hydraulic Cylinder

PowerTech 4.5L & 6.8L Diesel  
III A, Tier 3/Stage IIA, Tier 3/Stage



DOWNLOAD



John Deere Construction and Forestry  
Printed by Belgreen



TM12090

**Type:** Service Manual

**Language:** English

**Pages:** 888

**Format:** PDF

**Features:** Bookmarked, searchable, printable

**Compatibility:** Windows/Mac/Tablet/Mobile

This service manual contains important information for the maintenance, troubleshooting and servicing of the **John Deere 135D RTS Excavator Diagnostic, Operation and Test Service Manual (TM10742)**

In this manual you will find detailed specifications, illustrations, schematics, diagrams and step-by-step procedures to properly service and diagnose the machine to the manufacturer's standards.

**Contents:**

- General Information
- Specifications
- Serial Number Location
- Engine Specifications
- Engine Diagnostics
- Engine Tests and Adjustments
- Engine Repair
- Power Train
- Transmission
- Axles
- Differential
- PTO
- Hydraulic System
- Electrical System
- Electrical Tests and Diagnostics
- Wiring Diagram / Schematic
- Ignition and Charging
- Steering
- Brakes
- Wheels
- Operator's Platform
- Body Panels
- Disassembly and Assembly
- Diagnostics, Tests and Adjustments
- Troubleshooting
- and much more...

Please note this manual is in **downloadable PDF format only**. If you have any questions about this product or would like to request sample pages, please contact us and reference the product name or SKU.

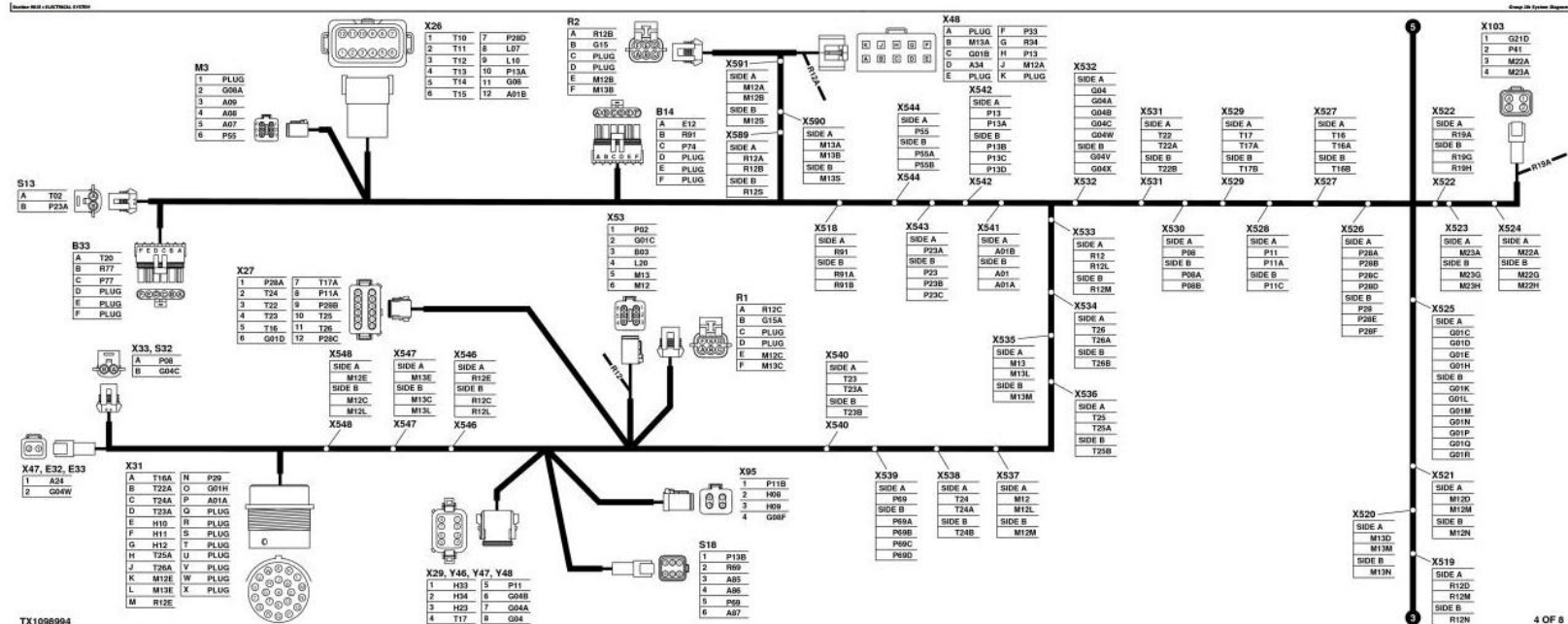

TX1000994  
Lead Center Harness (M2) Wiring Diagram (1 of 8) (R.A. - 48442)



Thank you very much  
for your reading.  
Please click here  
to get more information.