

John Deere 1450, 1550, 1450CWS, 1550CWS, 1450WTS and 1550WTS Combines Repair Service Manual (tm4910)

6230R, 6250R Tractors
Diagnostic Technical
Manual
(MY17, MY18, MY19)



JOHN HARE



COLLECTION

DIAGNOSTIC TECHNICAL MANUAL
6230R, 6250R Tractors (MY17, MY18, MY19)

TM409719 01DEC18 (ENGLISH)



John Deere GmbH & Co. KG
John Deere Werk Mannheim

Covers: (S.N.048751,1450,1450,1550,1550CWS,1450WTS,1550WTS)

Type: Service Manual

Language: English

Pages: 654

Format: PDF

Features: Bookmarked, searchable, printable

Compatibility: Windows/Mac/Tablet/Mobile

This service manual contains important information for the maintenance, troubleshooting and servicing of the **John Deere 1450, 1550, 1450CWS, 1550CWS, 1450WTS and 1550WTS Combines Repair Service Manual (tm4910)**

In this manual you will find detailed specifications, illustrations, schematics, diagrams and step-by-step procedures to properly service and diagnose the machine to the manufacturer's standards.

Contents:

- General Information
- Specifications
- Serial Number Location
- Engine Specifications
- Engine Diagnostics
- Engine Tests and Adjustments
- Engine Repair
- Power Train
- Transmission
- Axles
- Differential
- PTO
- Hydraulic System
- Electrical System
- Electrical Tests and Diagnostics
- Wiring Diagram / Schematic
- Ignition and Charging
- Steering
- Brakes
- Wheels
- Operator's Platform
- Body Panels
- Disassembly and Assembly
- Diagnostics, Tests and Adjustments
- Troubleshooting
- and much more...

Please note this manual is in **downloadable PDF format only**. If you have any questions about this product or would like to request sample pages, please contact us and reference the product name or SKU.

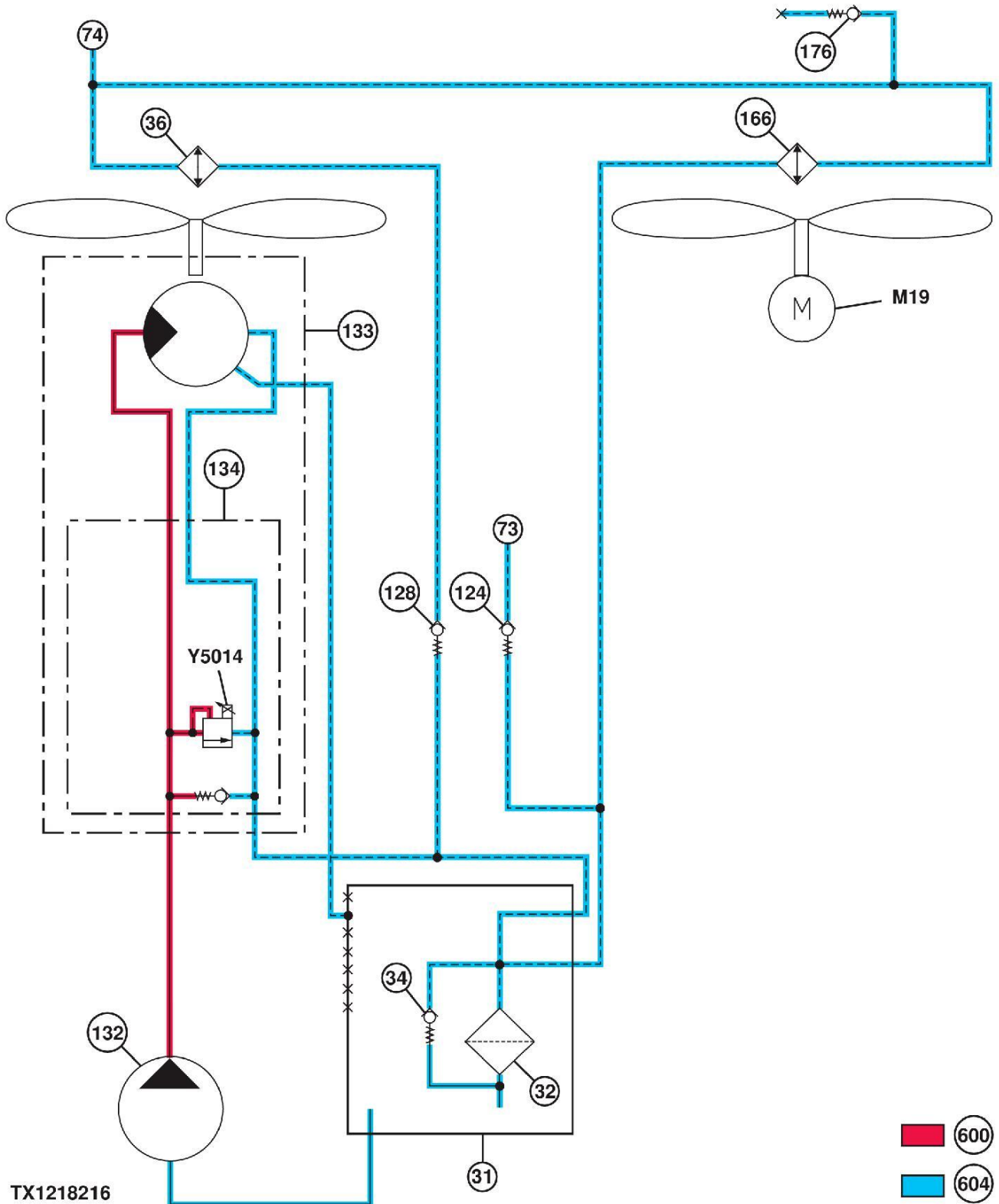

TX1218216-UN: Fan Drive Hydraulic System Schematic (with auxiliary oil cooler)

LEGEND:

- | | | |
|---------------------------------------|---------------------------------------|--|
| 31-Hydraulic Oil Tank | 124-Hydraulic Oil Cooler Bypass Valve | 176-Processor Return Oil Restriction Valve |
| 32-Return Filter | 128-Restriction Valve | 600-High-Pressure Oil |
| 34-Filter Bypass | 132-Fan Drive Pump | 604-Return Oil |
| 36-Hydraulic Oil Cooler | 133-Fan Drive Motor | M19-Auxiliary Oil Cooler Fan Motor |
| 73-From Right Control Valve (4-spool) | 134-Fan Speed Control Valve | Y5014-Variable Speed Fan Solenoid |
| 74-From Left Control Valve (5-spool) | 166-Auxiliary Oil Cooler | |



Thank you very much
for your reading.
Please click here
to get more information.