

John Deere 1790 Front-Fold Planter (SN.705101◆◆◆◆◆◆◆◆740100) Service Repair Technical Manual (TM2058)

**3156G Log Loader
Repair**

(PIN: 1FF3156G_
_F316001—)



JOHN HARE



COLLECTION

REPAIR TECHNICAL MANUAL

3156G Log Loader (PIN: 1FF3156G__F316001—)

TM14030X19 01DEC18 (ENGLISH)

For complete service information also see:

3156G Log Loader Operation and Test..... TM14029X19
3156G Log Loader Operators Manual..... OMT351760X19
6090 PowerTech™ OEM Diesel Engines (Final Tier 4/
Stage IV platform) dtm117719



Worldwide Construction and
Forestry Division

Covers: 1790,705101,740100)

Type: Service Manual

Language: English

Pages: 627

Format: PDF

Features: Bookmarked, searchable, printable

Compatibility: Windows/Mac/Tablet/Mobile

This service manual contains important information for the maintenance, troubleshooting and servicing of the **John Deere 1790 Front-Fold Planter (SN.705101◆◆◆◆◆740100) Service Repair Technical Manual (TM2058)**

In this manual you will find detailed specifications, illustrations, schematics, diagrams and step-by-step procedures to properly service and diagnose the machine to the manufacturer's standards.

Contents:

- General Information
- Specifications
- Serial Number Location
- Engine Specifications
- Engine Diagnostics
- Engine Tests and Adjustments
- Engine Repair
- Power Train
- Transmission
- Axles
- Differential
- PTO
- Hydraulic System
- Electrical System
- Electrical Tests and Diagnostics
- Wiring Diagram / Schematic
- Ignition and Charging
- Steering
- Brakes
- Wheels
- Operator's Platform
- Body Panels
- Disassembly and Assembly
- Diagnostics, Tests and Adjustments
- Troubleshooting
- and much more...

Please note this manual is in **downloadable PDF format only**. If you have any questions about this product or would like to request sample pages, please contact us and reference the product name or SKU.

Axle Shaft, Bearings, and Reduction Gears

Final Drive Remove and Install

SPECIFICATIONS	
Hydraulic Reservoir Capacity	122 L 32 gal.
Final Drive Oil Capacity (each)	4.8 L 1.3 gal.
Final Drive GTF 60 (U6 track) Weight (approximate)	260 kg 573 lb.
Final Drive GTF 80 (U7 track) Weight (approximate)	405 kg 893 lb.
Final Drive GTF 110 (U7 extreme duty track) Weight (approximate)	505 kg 1114 lb.
Final Drive Cap Screw Torque	500 N·m 368 lb.-ft.

REMOVAL

1. Park and prepare machine for service. [See Park and Prepare for Service Safely](#). (Group 0001.)
2. Turn battery disconnect switch to OFF position. [See Battery Disconnect Switch](#) - document OMT377711X19 - (Operator's Manual.)

3. Install vacuum pump or drain hydraulic reservoir.

Item	Measurement	Specification
Hydraulic Reservoir	Capacity	122 L 32 gal.

See [Drain and Refill Hydraulic Oil](#) - document OMT377711X19 - (Operator's Manual.)

See [Vacuum Pump Installation](#) - document TM14093X19 - (Group 9025-25.)

4. Remove track chain. [See Track Chain Remove and Install](#). (Group 0130.)
5. Remove sprocket. [See Sprocket Remove and Install](#). (Group 0130.)
6. Drain final drive oil. [See Drain and Refill Track Drive Planetary Oil](#) - document OMT377711X19 - (Operator's Manual.)

Item	Measurement	Specification
Final Drive Oil	Capacity (each)	4.8 L 1.3 gal.

7. Remove travel motor. [See Travel Motor Remove and Install](#). (Group 0260.)

8.  **CAUTION:**
Prevent possible crushing injury from heavy component. Use appropriate lifting device.
NOTE:

Mark the position of the final drive and travel motor before removal. The travel motor cannot be installed without the final drive in the correct position.

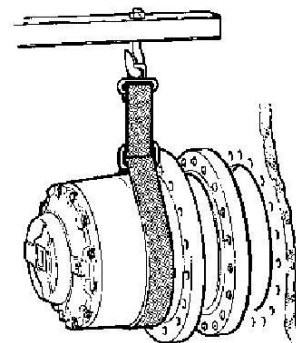

T191603-UN: Final Drive Removal

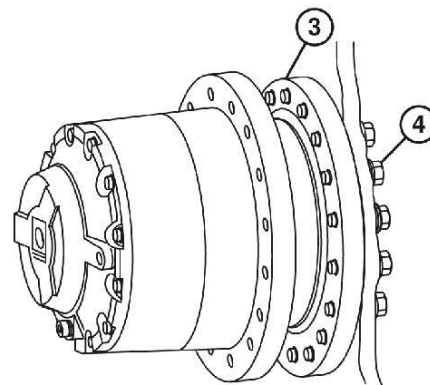

TX1175254A-UN: Final Drive Cap Screws

LEGEND:

3-Final Drive

4-Cap Screw (24 used)

Attach appropriate lifting device and remove final drive (3).

Item	Measurement	Specification
Final Drive GTF 60 (U6 track)	Weight (approximate)	260 kg 573 lb.
Final Drive GTF 80 (U7 track)	Weight (approximate)	405 kg 893 lb.
Final Drive GTF 110 (U7 extreme duty track)	Weight (approximate)	505 kg 1114 lb.

9. Inspect and repair as necessary.

[See Final Drive Disassemble](#) (Group 0250)



Thank you very much
for your reading.
Please click here
to get more information.