

# John Deere 250D, 300D Ser.2 Articulated Dump Truck (SN.from E642001) Service Repair Manual (TM12404)

312GR and 314G Skid Steer Loader Diagnostic





**OPERATION AND TEST MANUAL**

**models 312GR (PIN: 1T0312G\*\*\*J288093-), 314G (PIN:1T0314G\*\*\*J288093-)**

TM13847X19 26 FEB 16 (ENGLISH)

**For complete service information also see:**

|   |           |
|---|-----------|
| 120 Series Hydraulic Cylinders  | CTM120519 |
| 3TNV86, 4TNV86, 3TNV88, and 4TNV88 Diesel Engines(Final Tier 4/Stage IV platform) | CTM120419 |

  **DOWNLOAD** 

John Deere Commercial Worksite Products  
Printed by Belgreen



TM13847X19

**Covers:** 250D,(PIN:1DW250DX\*\*E642001-),300D,(PIN:1DW300DX\*\*E6420

**Type:** Service Manual

**Language:** English

**Pages:** 750

**Format:** PDF

**Features:** Bookmarked, searchable, printable

**Compatibility:** Windows/Mac/Tablet/Mobile

This service manual contains important information for the maintenance, troubleshooting and servicing of the **John Deere 250D, 300D Ser.2 Articulated Dump Truck (SN.from E642001) Service Repair Manual (TM12404)**

In this manual you will find detailed specifications, illustrations, schematics, diagrams and step-by-step procedures to properly service and diagnose the machine to the manufacturer's standards.

**Contents:**

- General Information
- Specifications
- Serial Number Location
- Engine Specifications
- Engine Diagnostics
- Engine Tests and Adjustments
- Engine Repair
- Power Train
- Transmission
- Axles
- Differential
- PTO
- Hydraulic System
- Electrical System
- Electrical Tests and Diagnostics
- Wiring Diagram / Schematic
- Ignition and Charging
- Steering
- Brakes
- Wheels
- Operator's Platform
- Body Panels
- Disassembly and Assembly
- Diagnostics, Tests and Adjustments
- Troubleshooting
- and much more...

Please note this manual is in **downloadable PDF format only**. If you have any questions about this product or would like to request sample pages, please contact us and reference the product name or SKU.

## Park Brake System Operation

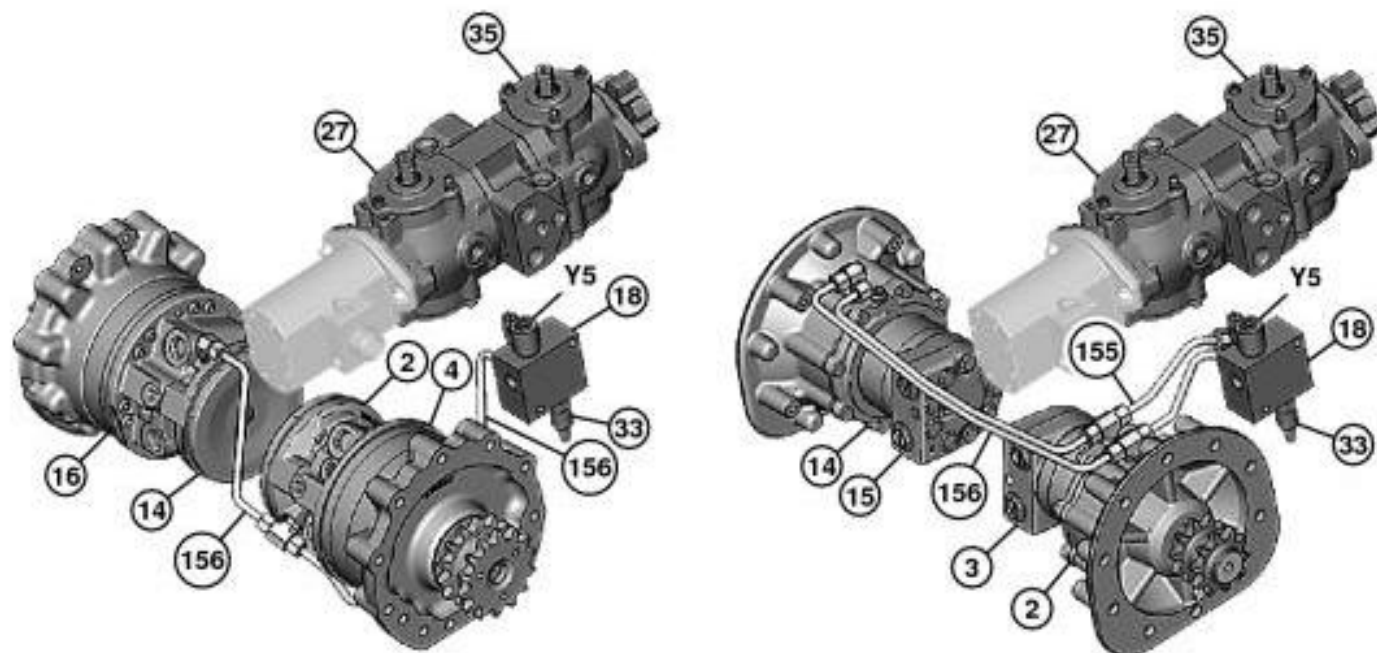

TX1205516

### Park Brake System Operation (two-speed shown left, single speed shown right)

#### LEGEND:

|     |                                    |
|-----|------------------------------------|
| 2   | Left Hydrostatic Motor Park Brake  |
| 3   | Left Hydrostatic Motor             |
| 4   | Left Hydrostatic Two-Speed Motor   |
| 14  | Right Hydrostatic Motor Park Brake |
| 15  | Right Hydrostatic Motor            |
| 16  | Right Hydrostatic Two-Speed Motor  |
| 18  | Park Brake Valve                   |
| 27  | Left Hydrostatic Pump              |
| 33  | Charge Pressure Relief Valve       |
| 35  | Right Hydrostatic Pump             |
| 155 | Park Brake Apply Line (2 used)     |
| 156 | Park Brake Release Line (2 used)   |
| Y5  | Park Brake Solenoid                |

Park brake system is electrically controlled, spring applied, and hydraulically released. Machine has left and right hydrostatic motor park brake (2 and 14) assemblies that are integrated into hydrostatic motors (3, 4, 15, and 16) and drive axles. Park brake solenoid (Y5) shares park brake valve (18) with charge pressure relief valve (33), located behind left hydrostatic motor.

When park brake switch is engaged, park brake solenoid is not energized and prevents charge pressure oil from flowing through park brake release line (156) to brake disc and spacer plate side of brake piston. When park brake is engaged on single speed machines, charge pressure oil fills spring side of brake piston through park brake apply line (155), assisting engagement of park brake when engine is running.

Park brake is applied by an internal spring that pushes brake piston against brake discs and spacer plates. Brake discs are splined to brake housing. Spacer plates are splined to park brake drive shaft. When brake discs and spacer plates are forced together, park brake drive shaft is prevented from rotating.

When park brake switch is disengaged, park brake solenoid is energized and allows charge pressure oil to flow to brake disc and spacer plate side of brake piston. When park brake is disengaged on single speed machines, charge pressure oil on spring side of piston is routed to return manifold. Charge pressure oil overcomes internal spring force, forcing brake piston away from brake discs and spacer plates. This disengages park brake and allows park brake drive shaft to rotate.

For more information:

- See [Hydrostatic Motor Operation—Single Speed](#). (Group 9026-05.)
- See [Hydrostatic Motor Operation—Two-Speed](#). (Group 9026-05.)



Thank you very much  
for your reading.  
Please click here  
to get more information.