

John Deere 260E, 310E Articulated Dump Truck (SN.F677827-) Repair Technical Manual (TM13842X19)

260E and 310E Articulated Dump Truck Repair

(PIN: 1DW260EX__F677827—
PIN: 1DW310EX__F677827—)



JOHN HARE



COLLECTION

REPAIR TECHNICAL MANUAL

260E and 310E Articulated Dump Truck
(PIN:1DW260EX__F677827—; PIN: 1DW310EX__F677827—)
TM13842X19 01DEC18 (ENGLISH)

For complete service information also see:

260E and 310E Articulated Dump Truck
Test.....TM13841X19
6090 PowerTech™ OEM
(V platform).....
Hydraulic Cylinders.....



Worldwide Construction and
Forestry Division

Covers: 260E,1DW260EX__,F677827(???,),310E,1DW310EX__,F677827

Type: Service Manual

Language: English

Pages: 335

Format: PDF

Features: Bookmarked, searchable, printable

Compatibility: Windows/Mac/Tablet/Mobile

This service manual contains important information for the maintenance, troubleshooting and servicing of the **John Deere 260E, 310E Articulated Dump Truck (SN.F677827-) Repair Technical Manual (TM13842X19)**

In this manual you will find detailed specifications, illustrations, schematics, diagrams and step-by-step procedures to properly service and diagnose the machine to the manufacturer's standards.

Contents:

- General Information
- Specifications
- Serial Number Location
- Engine Specifications
- Engine Diagnostics
- Engine Tests and Adjustments
- Engine Repair
- Power Train
- Transmission
- Axles
- Differential
- PTO
- Hydraulic System
- Electrical System
- Electrical Tests and Diagnostics
- Wiring Diagram / Schematic
- Ignition and Charging
- Steering
- Brakes
- Wheels
- Operator's Platform
- Body Panels
- Disassembly and Assembly
- Diagnostics, Tests and Adjustments
- Troubleshooting
- and much more...

Please note this manual is in **downloadable PDF format only**. If you have any questions about this product or would like to request sample pages, please contact us and reference the product name or SKU.

Output Damper Remove and Install

SPECIFICATIONS

Output Damper Cap Screw Torque	68 N·m 50 lb·ft
Universal Joint Cap Screw Torque	140 N·m 103 lb·ft

OTHER MATERIAL

Loctite®271™ Threadlocker (high strength)

MACHINE PREPARATION

1. Park and prepare machine for service. [See Park and Prepare for Service Safely](#). (Group 0001.)
2. Tilt cab. [See Tilt Cab](#) - document OMT329817X19 - (Operator's Manual.)
3. Turn battery disconnect switch to the OFF position. [See Battery Disconnect Switch](#) - document OMT329817X19 - (Operator's Manual.)

REMOVAL

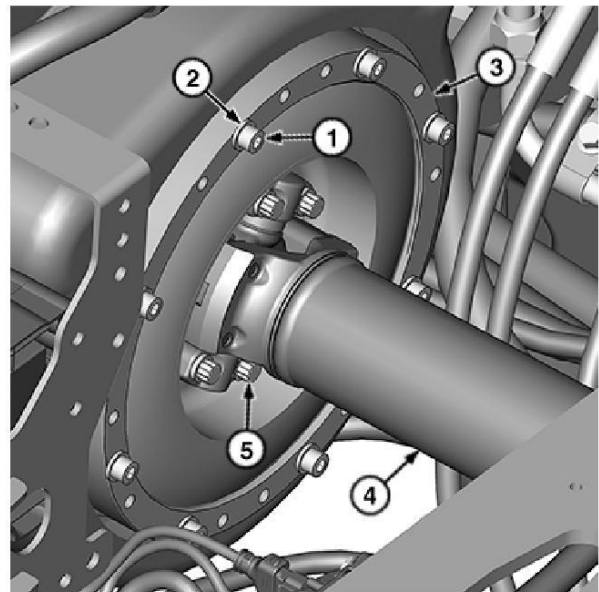

1. TX1231491A-UN: Output Damper (components removed for visibility)

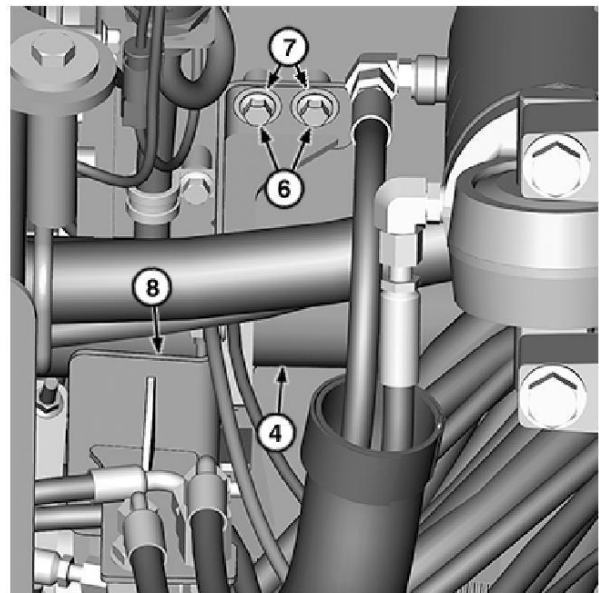

TX1231796A-UN: Drive Shaft Guard (bottom view)

LEGEND:

- 1-Output Damper Cap Screw (8 used)
- 2-Output Damper Washer (8 used)
- 3-Output Damper
- 4-Engine-to-Transmission Drive Shaft
- 5-Universal Joint Cap Screw (8 used)
- 6-Drive Shaft Guard Cap Screw (4 used)
- 7-Drive Shaft Guard Washer (4 used)
- 8-Drive Shaft Guard

Remove drive shaft guard cap screws (6) and washers (7). Lower drive shaft guard (8).

2. Remove universal joint cap screws (5) at both ends of drive shaft (4). Position drive shaft to allow output damper removal.
3. Remove output damper cap screws (1), washers (2), and output damper (3).
4. Repair or replace output damper.

INSTALLATION

Installation is reverse of removal procedure.



Thank you very much
for your reading.
Please click here
to get more information.