

John Deere 27Czts and 35Czts Compact Excavator Service Repair Technical Manual (TM2053)

John Deere 190E Excavator Repair

REPAIR TECHNICAL MANUAL

190E

TM1540 21FEB05 (ENGLISH)

For complete service information also see:

190E Excavator Operation and Tests	tm1539
North American 3029 , 4039, 4045, 6059 and 6068 Diesel Engines	ctm8
Alternators and Starting Motors	ctm77
JDG10274 Ultrasonic Undercarriage Measurement Gauge	CTM10001



John Deere Construction and Forestry

Covers: 27Czts,35Czts

Type: Service Manual

Language: English

Pages: 437

Format: PDF

Features: Bookmarked, searchable, printable

Compatibility: Windows/Mac/Tablet/Mobile

This service manual contains important information for the maintenance, troubleshooting and servicing of the **John Deere 27Czts and 35Czts Compact Excavator Service Repair Technical Manual (TM2053)**

In this manual you will find detailed specifications, illustrations, schematics, diagrams and step-by-step procedures to properly service and diagnose the machine to the manufacturer's standards.

Contents:

- General Information
- Specifications
- Serial Number Location
- Engine Specifications
- Engine Diagnostics
- Engine Tests and Adjustments
- Engine Repair
- Power Train
- Transmission
- Axles
- Differential
- PTO
- Hydraulic System
- Electrical System
- Electrical Tests and Diagnostics
- Wiring Diagram / Schematic
- Ignition and Charging
- Steering
- Brakes
- Wheels
- Operator's Platform
- Body Panels
- Disassembly and Assembly
- Diagnostics, Tests and Adjustments
- Troubleshooting
- and much more...

Please note this manual is in **downloadable PDF format only**. If you have any questions about this product or would like to request sample pages, please contact us and reference the product name or SKU.

Rear Cab Electrical Component Identification

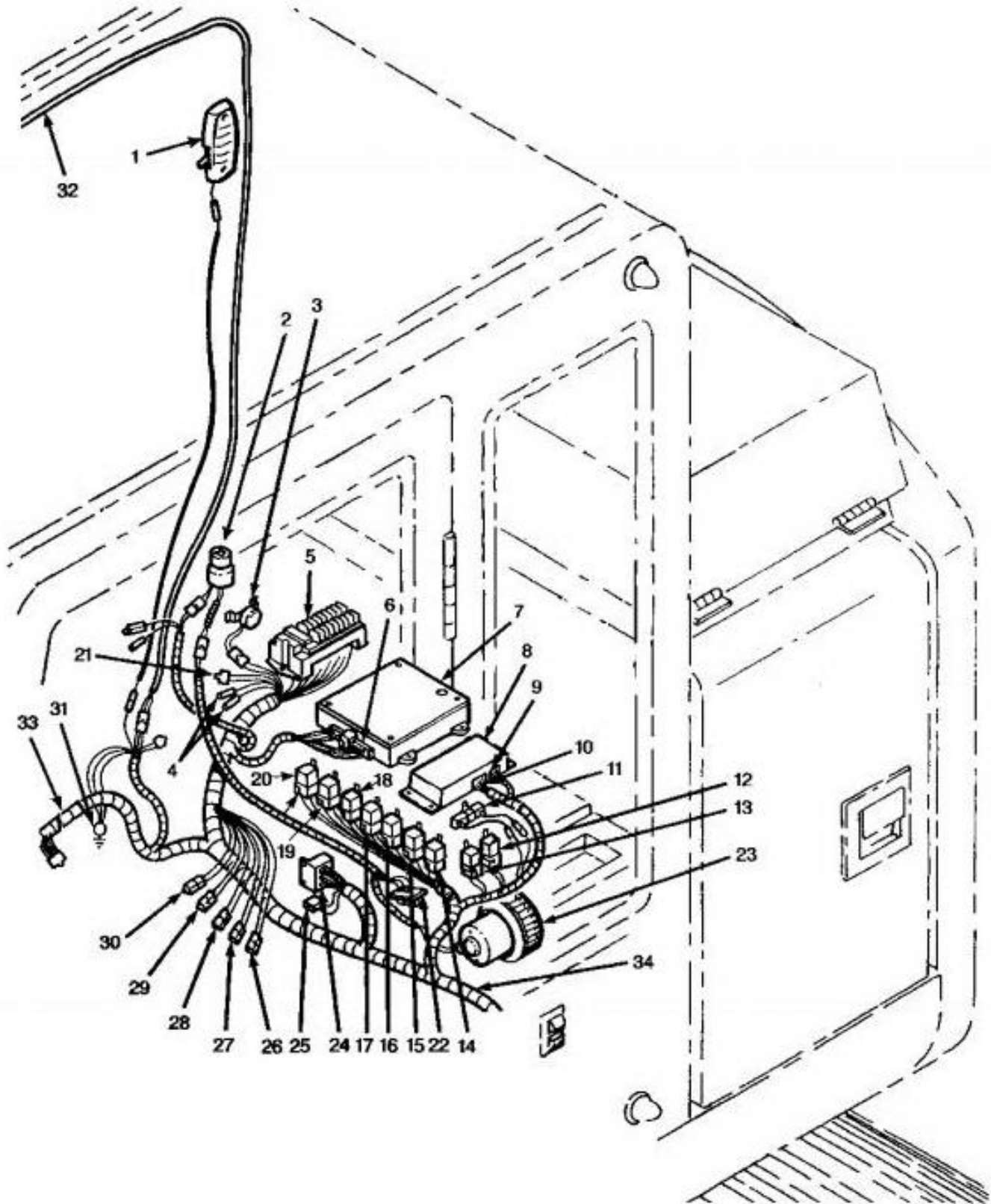

Rear Cab Electrical Components

LEGEND:

- 1 (E4) Dome Light (RED/WHT)
- 2 (S31) Heater Blower Switch (BRN, BLK)
- 3 (B11) Monitor Buzzer (GRN/BLU)



Thank you very much
for your reading.
Please click here
to get more information.