

# John Deere 27ZTS Compact Excavator Service Repair Technical Manual (TM1837)

## 544K-II 4WD Loader Repair

(PIN: 1DW544K\_\_\_F677549—)



JOHN HARE



COLLECTION

### REPAIR TECHNICAL MANUAL

544K-II 4WD Loader (PIN: 1DW544K\_\_\_F677549—)

TM14144X19 01DEC18 (ENGLISH)

For complete service information also see:

TeamMate™ IV 1200 Series Inboard Planetary Axes ..... ctm140119  
544K-II 4WD Loader Operation and Test ..... TM14142X19  
PowerTech 6068 OEM Diesel Engines (Final Tier 4/Stage IV  
platform) Level 33 ECU ..... ctm120019  
Hydraulic Cylinders ..... 14142X19



Worldwide Construction and  
Forestry Division

Covers: 27ZTS

**Type:** Service Manual

**Language:** English

**Pages:** 627

**Format:** PDF

**Features:** Bookmarked, searchable, printable

**Compatibility:** Windows/Mac/Tablet/Mobile

This service manual contains important information for the maintenance, troubleshooting and servicing of the **John Deere 27ZTS Compact Excavator Service Repair Technical Manual (TM1837)**

In this manual you will find detailed specifications, illustrations, schematics, diagrams and step-by-step procedures to properly service and diagnose the machine to the manufacturer's standards.

**Contents:**

- General Information
- Specifications
- Serial Number Location
- Engine Specifications
- Engine Diagnostics
- Engine Tests and Adjustments
- Engine Repair
- Power Train
- Transmission
- Axles
- Differential
- PTO
- Hydraulic System
- Electrical System
- Electrical Tests and Diagnostics
- Wiring Diagram / Schematic
- Ignition and Charging
- Steering
- Brakes
- Wheels
- Operator's Platform
- Body Panels
- Disassembly and Assembly
- Diagnostics, Tests and Adjustments
- Troubleshooting
- and much more...

Please note this manual is in **downloadable PDF format only**. If you have any questions about this product or would like to request sample pages, please contact us and reference the product name or SKU.

**IMPORTANT:**

5. **Avoid machine damage. Do not reuse drive shaft universal joint cap screws.**

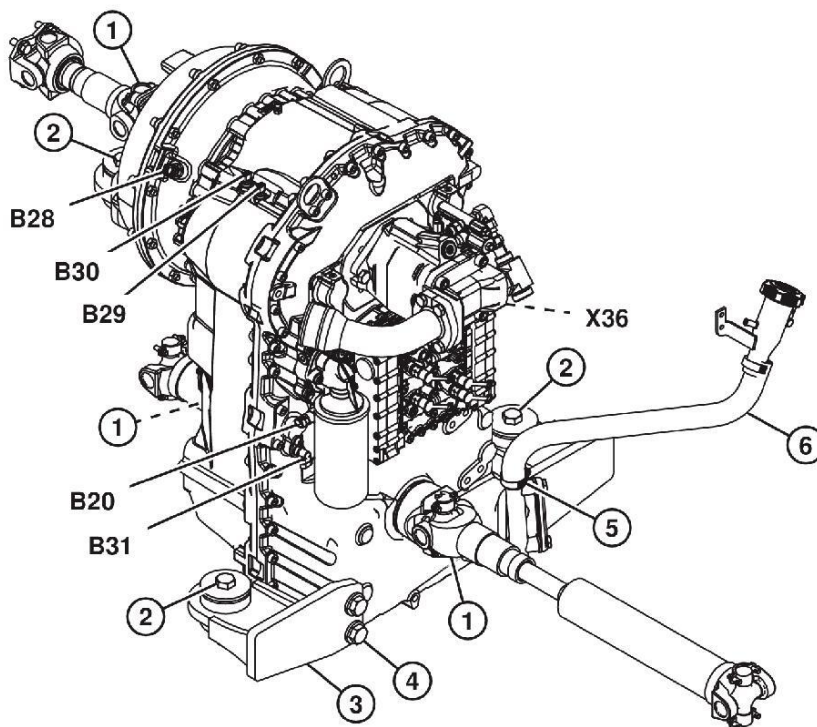

**TX1107405**

TX1107405-UN: Transmission

**LEGEND:**

- 1-Drive Shaft (3 used)
- 2-Transmission Isolator Cap Screw (3 used)
- 3-Transmission Mounting Bracket (3 used)
- 4-Cap Screw (8 used)
- 5-Hose Clamp
- 6-Transmission Oil Fill Tube
- B20-Transmission Oil Filter Restriction Switch Connector
- B28-Torque Converter Input Speed Sensor Connector
- B29-Torque Converter Output Speed Sensor Connector
- B30-Internal Clutch Speed Sensor Connector
- B31-Transmission Output Shaft Speed Sensor Connector
- X36-Transmission Harness-to-Transmission Control Valve Harness 16-Pin Connector

Disconnect drive shafts (1) from transmission. Discard universal joint cap screws. See [Universal Joint and Drive Shaft Remove and Install](#). (Group 0225.)

6. Tag and disconnect hydraulic lines from main hydraulic pump and transmission. Close all openings using caps and plugs.  
See [Power Train Component Location](#) - document TM14142X19 - (Group 9020-10.)  
See [Loader and Hydraulic Cooling Circuit Component Location](#) - document TM14142X19 - (Group 9025-10.)
7. Tag and disconnect electrical connectors (B20, B28, B29, B30, B31, and X36) from transmission. See [Transmission Harness \(W10\) Component Location](#) - document TM14142X19 - (Group 9015-10.)
8. Drain transmission oil into an appropriate container for storage or disposal. See [Drain and Refill Transmission Oil and Replace Filter](#) - document OMT387131X19 - (Operator's Manual.)
9. Loosen hose clamp (5) and disconnect transmission oil fill tube (6).



**CAUTION:**

Prevent crushing injury from heavy component. Use appropriate lifting device.

Install appropriate lifting device to transmission lifting brackets and support transmission.

Item	Measurement	Specification
Transmission with Hydraulic Pump Attached	Weight (approximate)	431 kg 950 lb.

11. Remove transmission isolator cap screws (2).
12. Remove cap screws (4) and transmission mounting brackets (3) from transmission.
13. Remove transmission and place in D01003AA Repair Stand using JDG1129A Mounting Bracket.
14. Clean and inspect parts. Repair or replace parts as necessary.



Thank you very much  
for your reading.  
Please click here  
to get more information.