

John Deere 316GR and 318G Skid Steer Loader Repair Service Manual (TM13861X19)

F441M, F441R Round
Baler Diagnostic



JOHN HARE



COLLECTION

DIAGNOSTIC TECHNICAL MANUAL
F441M, F441R Round Balers

TM301519 01DEC18 (ENGLISH)

For complete service information also see...



Covers: 316GR,1T0316G_,_G298752❖❖❖❖❖❖❖),318G,1T0318G_,_G298752❖

Type: Service Manual

Language: English

Pages: 242

Format: PDF

Features: Bookmarked, searchable, printable

Compatibility: Windows/Mac/Tablet/Mobile

This service manual contains important information for the maintenance, troubleshooting and servicing of the **John Deere 316GR and 318G Skid Steer Loader Repair Service Manual (TM13861X19)**

In this manual you will find detailed specifications, illustrations, schematics, diagrams and step-by-step procedures to properly service and diagnose the machine to the manufacturer's standards.

Contents:

- General Information
- Specifications
- Serial Number Location
- Engine Specifications
- Engine Diagnostics
- Engine Tests and Adjustments
- Engine Repair
- Power Train
- Transmission
- Axles
- Differential
- PTO
- Hydraulic System
- Electrical System
- Electrical Tests and Diagnostics
- Wiring Diagram / Schematic
- Ignition and Charging
- Steering
- Brakes
- Wheels
- Operator's Platform
- Body Panels
- Disassembly and Assembly
- Diagnostics, Tests and Adjustments
- Troubleshooting
- and much more...

Please note this manual is in **downloadable PDF format only**. If you have any questions about this product or would like to request sample pages, please contact us and reference the product name or SKU.

Hydrostatic Steering - LAGU Steering Units

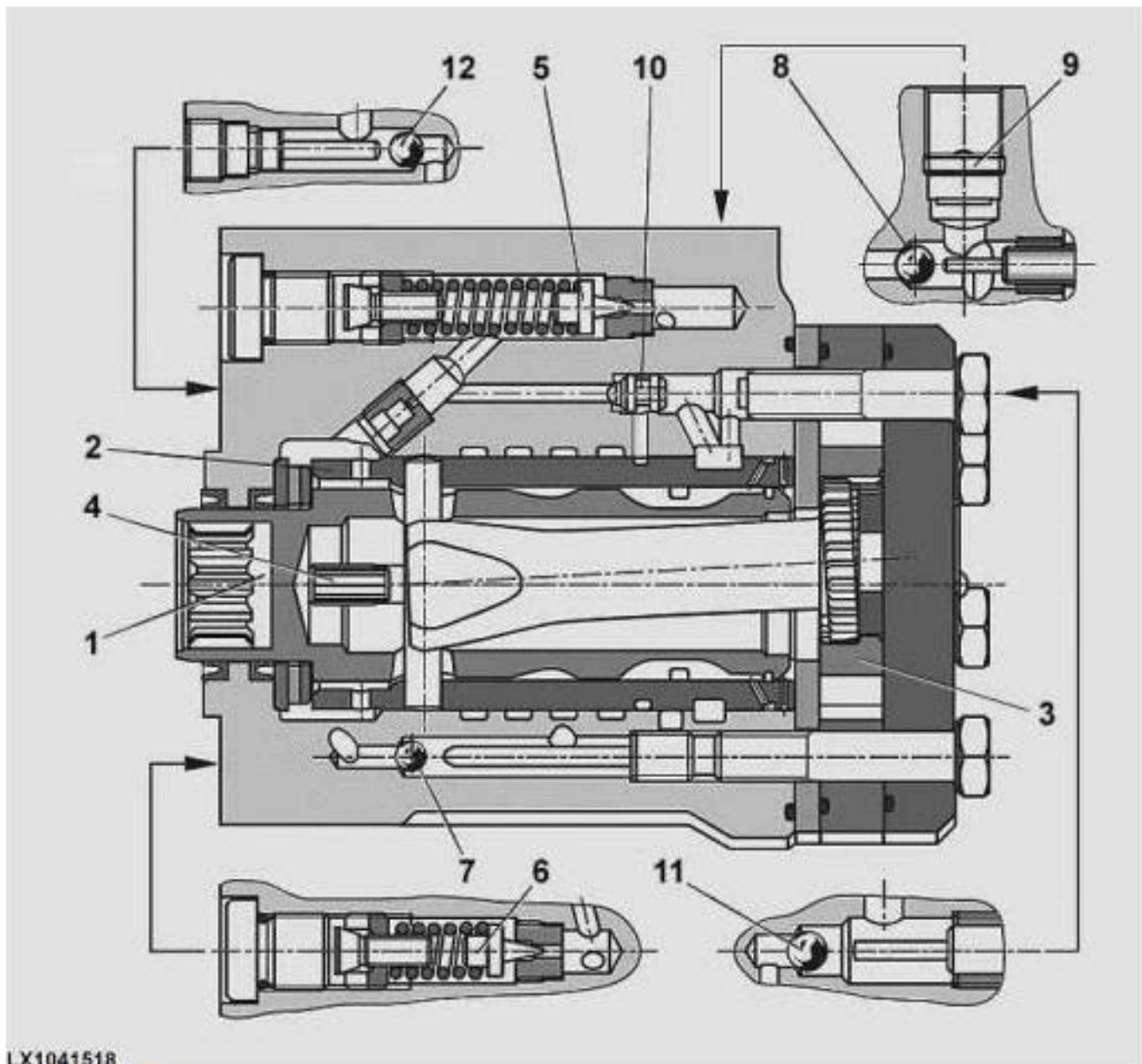

LX1041518

LEGEND:

- 1 Control Plunger
- 2 Control Sleeve
- 3 Gerotor Set
- 4 Centering Spring
- 5 Pressure-Limiting Valve
- 6 Shock Valve
- 7 Suction Valve
- 8 Suction Valve
- 9 Check Valve
- 10 Shut-Off Valve
- 11 Check Valve
- 12 Check Valve

Control plunger (1) of the control valve is twisted in relation to control sleeve (2) by the



Thank you very much
for your reading.
Please click here
to get more information.