

John Deere 3756G, 3756GLC (SN. D376001-) Log Loader Operation & Test Technical Manual (TM14019X19)

2656GLC Log Loader Operation and Test

(PIN: 1FF2656G__C266001—;
PIN: 1FF2656G__D266001—)



JOHN HARE



COLLECTION

OPERATION & TEST TECHNICAL MANUAL

2656GLC Log Loader (PIN: 1FF2656G__C266001—;
PIN: 1FF2656G__D266001—)

TM14039X19 01DEC18 (ENGLISH)

For complete service information also see:

2656GLC Log Loader Operators Manual OMT388073X19
2656GLC Log Loader Repair TM14040X19
PowerTech 4045, 6088 Diesel Engine Level 14 Electronic Fuel System with the Denso High Pressure Common Rail (HPCR) Level 14 ECU
PowerTech 4.5L & 6.8L Diesel Engines with the Denso High Pressure Common Rail (HPCR) Level 14 ECU, Tier 2/Stage II, Tier 3/Stage III, (Base Engine)



Worldwide Construction and Forestry Division

Covers: 3756G,3756GLC,1FF7576G__,_D376001 (???)

Type: Service Manual

Language: English

Pages: 804

Format: PDF

Features: Bookmarked, searchable, printable

Compatibility: Windows/Mac/Tablet/Mobile

This service manual contains important information for the maintenance, troubleshooting and servicing of the **John Deere 3756G, 3756GLC (SN. D376001-) Log Loader Operation & Test Technical Manual (TM14019X19)**

In this manual you will find detailed specifications, illustrations, schematics, diagrams and step-by-step procedures to properly service and diagnose the machine to the manufacturer's standards.

Contents:

- General Information
- Specifications
- Serial Number Location
- Engine Specifications
- Engine Diagnostics
- Engine Tests and Adjustments
- Engine Repair
- Power Train
- Transmission
- Axles
- Differential
- PTO
- Hydraulic System
- Electrical System
- Electrical Tests and Diagnostics
- Wiring Diagram / Schematic
- Ignition and Charging
- Steering
- Brakes
- Wheels
- Operator's Platform
- Body Panels
- Disassembly and Assembly
- Diagnostics, Tests and Adjustments
- Troubleshooting
- and much more...

Please note this manual is in **downloadable PDF format only**. If you have any questions about this product or would like to request sample pages, please contact us and reference the product name or SKU.

Travel Pilot Control Valve Operation

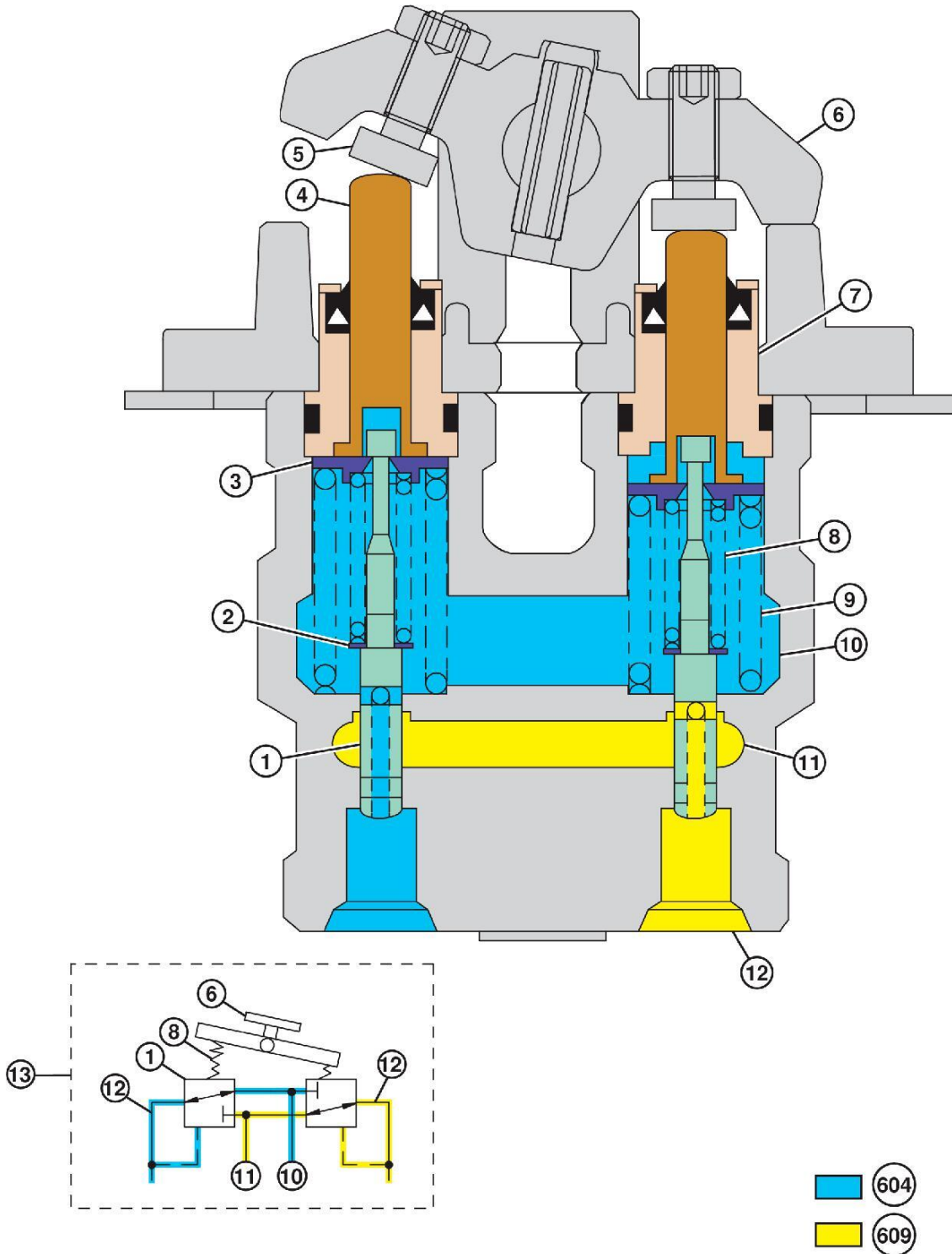

TX1086424

TX1086424-UN: Travel Pilot Control Valve Operation

LEGEND:

- | | | |
|---|--|--|
| <ul style="list-style-type: none"> 1-Spool 2-Washer 3-Spring Guide 4-Plunger 5-Adjustment Screw | <ul style="list-style-type: none"> 6-Cam and Pedal 7-Sleeve 8-Balance Spring 9-Return Spring 10-Port T to Hydraulic Oil Tank | <ul style="list-style-type: none"> 11-Port P From Pilot Shutoff Solenoid Valve 12-Port 1, 2, 3, or 4 to Control Valve Pilot Cap 13-Travel Pilot Control Valve—Full Stroke 604-Return Oil 609-Pilot Oil |
|---|--|--|

The travel pilot control valve regulates the pilot oil (609) pressure to actuate the pilot valves in the pilot signal manifold and to shift the control valve spools to actuate the travel functions.

See Pilot Signal Manifold Operation for pilot valve operation. (Group 9025-05.)



Thank you very much
for your reading.
Please click here
to get more information.