

# John Deere 410J Backhoe Loader (SN. before 161616) Service Repair Technical Manual (TM10147)

## John Deere 401D Tractor



**Covers:** 410J,161616)

**Type:** Service Manual

**Language:** English

**Pages:** 722

**Format:** PDF

**Features:** Bookmarked, searchable, printable

**Compatibility:** Windows/Mac/Tablet/Mobile

This service manual contains important information for the maintenance, troubleshooting and servicing of the **John Deere 410J Backhoe Loader (SN. before 161616) Service Repair Technical Manual (TM10147)**

In this manual you will find detailed specifications, illustrations, schematics, diagrams and step-by-step procedures to properly service and diagnose the machine to the manufacturer's standards.

**Contents:**

- General Information
- Specifications
- Serial Number Location
- Engine Specifications
- Engine Diagnostics
- Engine Tests and Adjustments
- Engine Repair
- Power Train
- Transmission
- Axles
- Differential
- PTO
- Hydraulic System
- Electrical System
- Electrical Tests and Diagnostics
- Wiring Diagram / Schematic
- Ignition and Charging
- Steering
- Brakes
- Wheels
- Operator's Platform
- Body Panels
- Disassembly and Assembly
- Diagnostics, Tests and Adjustments
- Troubleshooting
- and much more...

Please note this manual is in **downloadable PDF format only**. If you have any questions about this product or would like to request sample pages, please contact us and reference the product name or SKU.

## Steering Cylinder Remove

[1] -

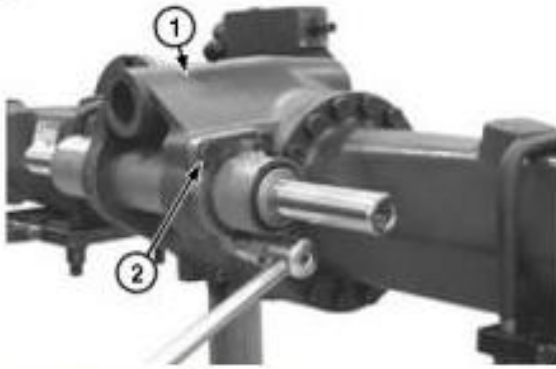

### LEGEND:

- 1 Axle Housing
- 2 Steering Cylinder Cap Screw (3 used)

### Steering Cylinder Cap Screws

Remove steering cylinder cap screws (2) from axle housing (1).

[2] -

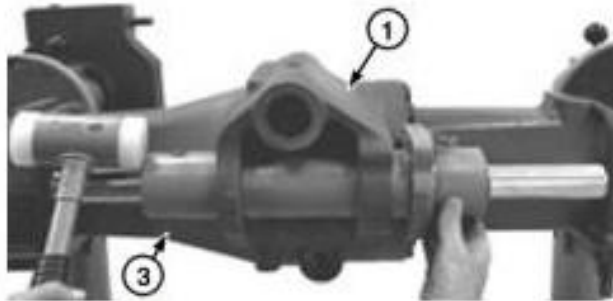

### LEGEND:

- 1 Axle Housing
- 3 Steering Cylinder

### Steering Cylinder

Remove steering cylinder (3) from axle housing.

[3] - For disassembly of steering cylinder, [see Mechanical Front Wheel Drive \(MFWD\) Axle Steering Cylinder Disassemble and Assemble](#). (Group 0960.)

## Knuckle Housing Remove

[1] -

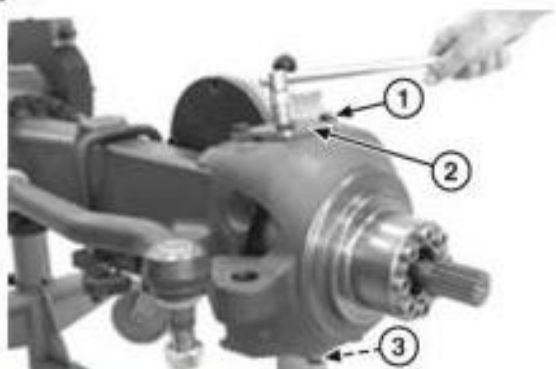

### LEGEND:

- 1 Cap Screw (8 used)
- 2 Upper King Pin
- 3 Lower King Pin

### King Pin Cap Screws

Drain oil from axle housing, [see Change MFWD Front Axle Housing Oil—If Equipped](#). (Operator's Manual.)

[2] - Remove cap screws (1) from upper king pin (2) and lower king pin (3).

[3] - Remove upper and lower king pins.

[4] -



Thank you very much  
for your reading.  
Please click here  
to get more information.