

**John Deere 6110M, 6120M, 6125M, 6130M, 6135M,
6140M, 6145M, 6155M, 6175M, 6195M
Diagnostic&Tests TM408419**



**200D and 200DLC
Excavator
Repair**

**TECHNICAL MANUAL
200D and 200DLC Excavator Repair**



Covers: 6120M,6135M,6145M,6110M,6155M,6175M,6195M,6130M,6140M,6

Type: Service Manual

Language: English

Pages: 5518

Format: PDF

Features: Bookmarked, searchable, printable

Compatibility: Windows/Mac/Tablet/Mobile

This service manual contains important information for the maintenance, troubleshooting and servicing of the **John Deere 6110M, 6120M, 6125M, 6130M, 6135M, 6140M, 6145M, 6155M, 6175M, 6195M**

Diagnostic&Tests TM408419

In this manual you will find detailed specifications, illustrations, schematics, diagrams and step-by-step procedures to properly service and diagnose the machine to the manufacturer's standards.

Contents:

- General Information
- Specifications
- Serial Number Location
- Engine Specifications
- Engine Diagnostics
- Engine Tests and Adjustments
- Engine Repair
- Power Train
- Transmission
- Axles
- Differential
- PTO
- Hydraulic System
- Electrical System
- Electrical Tests and Diagnostics
- Wiring Diagram / Schematic
- Ignition and Charging
- Steering
- Brakes
- Wheels
- Operator's Platform
- Body Panels
- Disassembly and Assembly
- Diagnostics, Tests and Adjustments
- Troubleshooting
- and much more...

Please note this manual is in **downloadable PDF format only**. If you have any questions about this product or would like to request sample pages, please contact us and reference the product name or SKU.

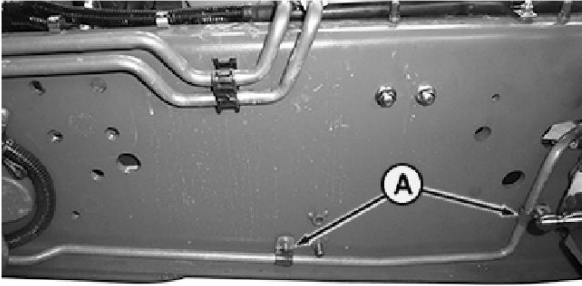

11. Attach commercially available ring eyelet (A) and attach to suitable hoist.

LX265508-UN: .

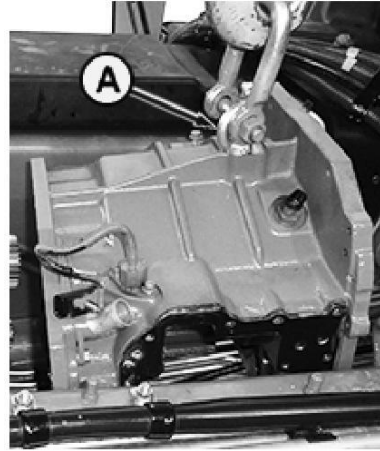

8. LX265505-UN: .
Remove nuts (A) and unfasten the cable from the holders.
9. Disengage connecting rod from the bell crank lever of the park lock.
10. Loosen all (18) special screws (inner Torx, outer hexagonal).

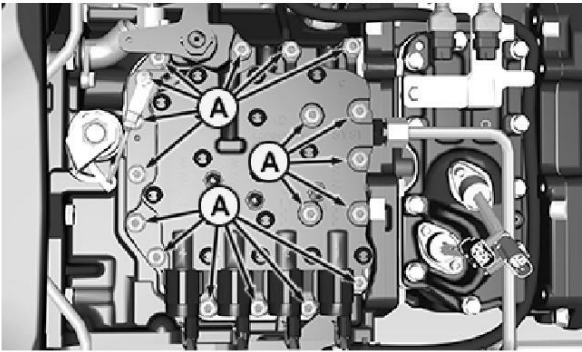

LX265507-UN: Main frame removed for illustration purposes.

12. Remove special nuts (A).

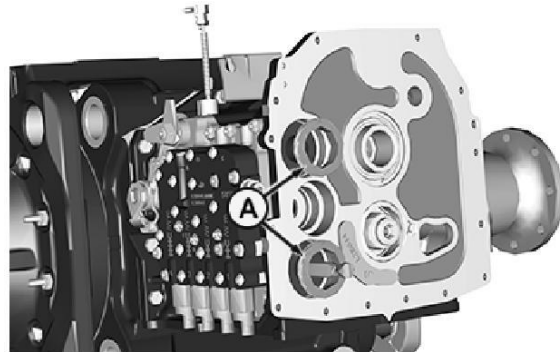

LX265509-UN: Special Nuts on Range Transmission

NOTE:

Not all screws can be removed. Some remain on the switch cover.

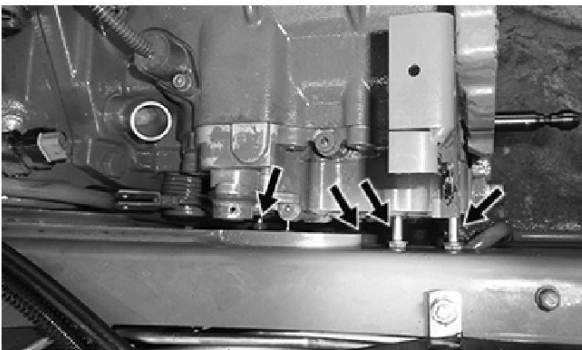

LX265506-UN: .

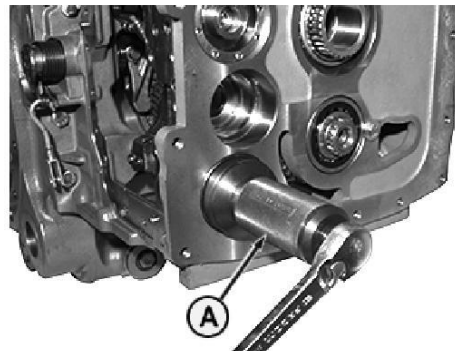

13. LX265510-UN: .
Place assembly tool on actuator nut KJD10919 (A) as shown.

Unfasten the shift cover and take it out upwards.



Thank you very much
for your reading.
Please click here
to get more information.