

John Deere 6150M and 6170M 2WD or MFWD Tractors Service Repair Technical Manual (TM405919)

130G and 130GLC Excavator Operation and Test

(PIN: 1F9130GX_ _D040001—)



JOHN HARE



COLLECTION

OPERATION & TEST TECHNICAL MANUAL

130G and 130GLC Excavator

(PIN: 1F9130GX_ _D040001—)

TM14288X19 01DEC18 (ENGLISH)

For complete service information also see:

130G and 130GLC Excavator Repair..... TM14288X19

PowerTech 4.5L & 6.8L Diesel Engines Tier 1/Stage I, Tier 2/Stage II, Tier 3/Stage IIIA, Tier 3/Stage IIIB Tier 3/Stage III, (Base Engine)..... tm104

PowerTech E 4.5 and 6.8L Diesel Engines with Electronic Fuel System With



Worldwide Construction and Forestry Division

Covers: 6150M,6170M

Type: Service Manual

Language: English

Pages: 1417

Format: PDF

Features: Bookmarked, searchable, printable

Compatibility: Windows/Mac/Tablet/Mobile

This service manual contains important information for the maintenance, troubleshooting and servicing of the **John Deere 6150M and 6170M 2WD or MFWD Tractors Service Repair Technical Manual (TM405919)**

In this manual you will find detailed specifications, illustrations, schematics, diagrams and step-by-step procedures to properly service and diagnose the machine to the manufacturer's standards.

Contents:

- General Information
- Specifications
- Serial Number Location
- Engine Specifications
- Engine Diagnostics
- Engine Tests and Adjustments
- Engine Repair
- Power Train
- Transmission
- Axles
- Differential
- PTO
- Hydraulic System
- Electrical System
- Electrical Tests and Diagnostics
- Wiring Diagram / Schematic
- Ignition and Charging
- Steering
- Brakes
- Wheels
- Operator's Platform
- Body Panels
- Disassembly and Assembly
- Diagnostics, Tests and Adjustments
- Troubleshooting
- and much more...

Please note this manual is in **downloadable PDF format only**. If you have any questions about this product or would like to request sample pages, please contact us and reference the product name or SKU.

Theory of Operation

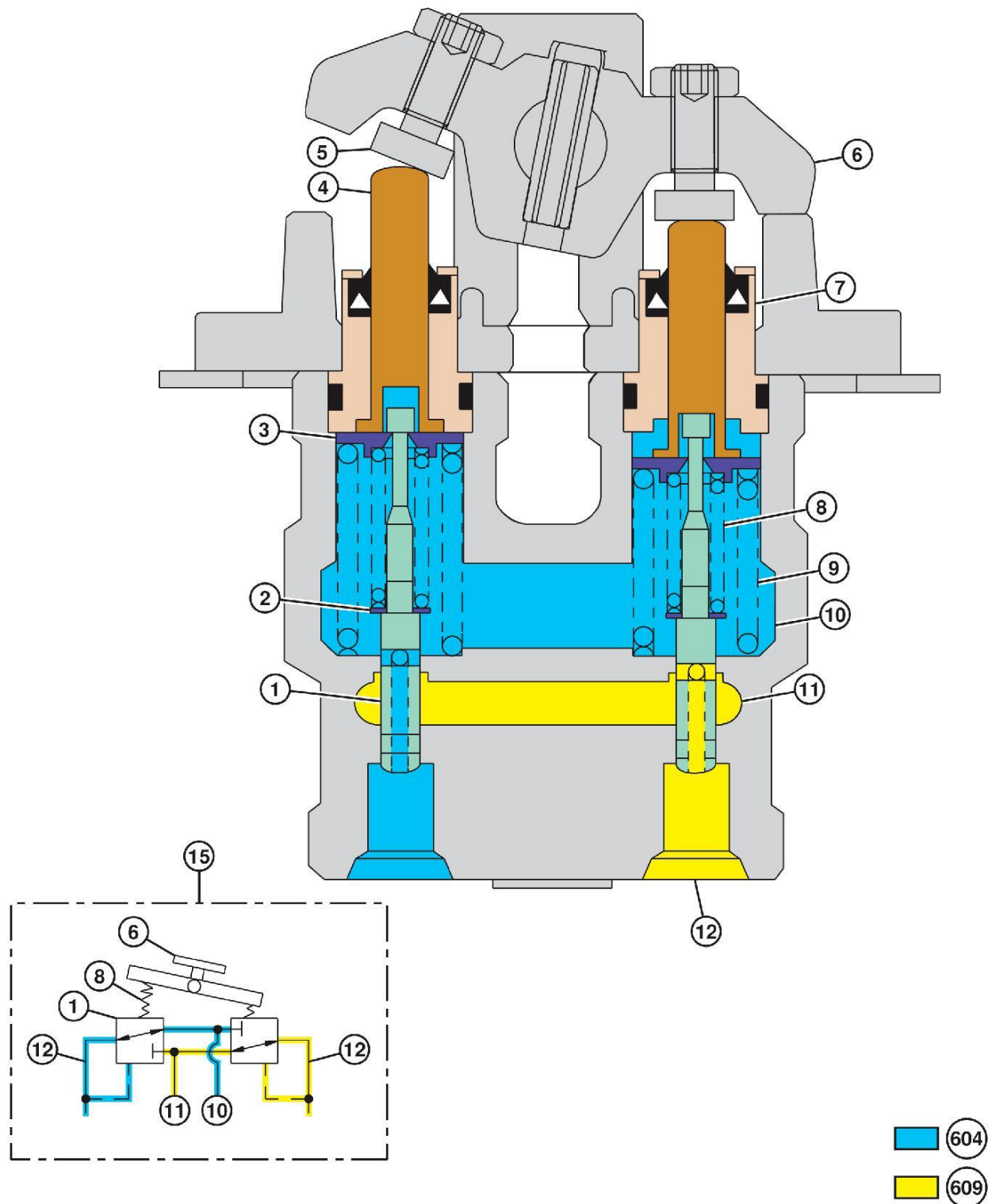

TX1199031

TX1199031-JN: Auxiliary Pilot Control Valve

LEGEND:

1-Spool

2-Washer

3-Spring Guide

4-Plunger

5-Adjustment Screw

6-Pedal

7-Sleeve

8-Balance Spring

9-Return Spring

10-To Pilot Shutoff Solenoid Valve Port T2

11-From Pilot Shutoff Solenoid Valve Port A3

12-Port 13 or 14 to Control Valve Pilot Cap

15-Auxiliary Pilot Control Valve—Full Stroke

604-Pilot Oil

609-Return Oil

One pilot control valve is used to control the auxiliary functions. The pilot control valve contains two valve assemblies. The valves are controlled by movement of the pedals against the plunger (4). The ports (10, 11, and 12) in housing are identified by numbers and letters next to each port.

In neutral, the spool is pushed up by the return spring (9) pushing the plunger up. The return springs hold the pedal in the neutral position. With the spool up, ports 13 and 14 to the control valve pilot cap (12) are open to pilot shutoff solenoid valve port T2 (10) through the passage and holes in spool. Pilot oil from the pilot shutoff solenoid valve port A3 (11) is blocked by the spool.



Thank you very much
for your reading.
Please click here
to get more information.