

John Deere 643K Wheeled Feller Buncher Diagnostic, Operation and Test Service Manual (TM11361)

MaxEmerge 5 &
ExactEmerge Row Unit
Repair

JOHN HARE

COLLECTION

REPAIR TECHNICAL MANUAL
MaxEmerge™ 5 1735 and ExactEmerge™ Row Unit Repair
TM131219 10 NOV 15 (ENGLISH)

For complete service information also see:
Machine Connection Information CTM441
120 Series Hydraulic Cylinders CTM120519

PDF  **DOWNLOAD** 

John Deere Agriculture
Printed by Belgroen



Covers: 643K

Type: Service Manual

Language: English

Pages: 777

Format: PDF

Features: Bookmarked, searchable, printable

Compatibility: Windows/Mac/Tablet/Mobile

This service manual contains important information for the maintenance, troubleshooting and servicing of the **John Deere 643K Wheeled Feller Buncher Diagnostic, Operation and Test Service Manual (TM11361)**

In this manual you will find detailed specifications, illustrations, schematics, diagrams and step-by-step procedures to properly service and diagnose the machine to the manufacturer's standards.

Contents:

- General Information
- Specifications
- Serial Number Location
- Engine Specifications
- Engine Diagnostics
- Engine Tests and Adjustments
- Engine Repair
- Power Train
- Transmission
- Axles
- Differential
- PTO
- Hydraulic System
- Electrical System
- Electrical Tests and Diagnostics
- Wiring Diagram / Schematic
- Ignition and Charging
- Steering
- Brakes
- Wheels
- Operator's Platform
- Body Panels
- Disassembly and Assembly
- Diagnostics, Tests and Adjustments
- Troubleshooting
- and much more...

Please note this manual is in **downloadable PDF format only**. If you have any questions about this product or would like to request sample pages, please contact us and reference the product name or SKU.

Power Train Component Location

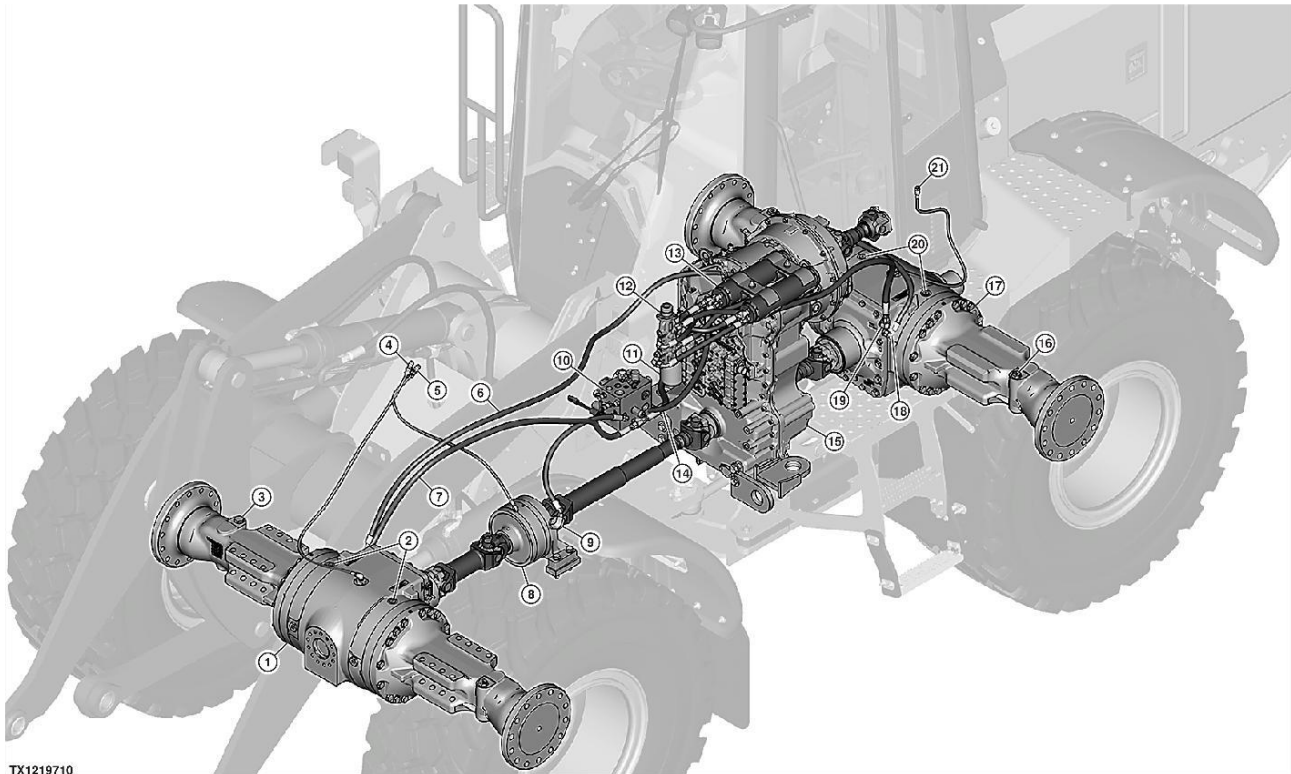

TX1219710

TX1219710-UN: Power Train Component Location

LEGEND:

- | | | |
|--|---|---|
| 1-Front Axle | 8-Park Brake | 16-Rear Axle Dipstick |
| 2-Front Axle Service Brake Inspection Port (2 used) | 9-Park Brake-to-Hydraulic Pump Manifold Line | 17-Rear Axle |
| 3-Front Axle Dipstick | 10-Hydraulic Pump Manifold | 18-Rear Axle Differential Lock-to-Hydraulic Pump Manifold Line (if equipped) |
| 4-Front Axle Breather | 11-Transmission Oil Filter | 19-Rear Axle Service Brake-to-Service Brake Valve Line |
| 5-Park Brake Breather | 12-Service Brake Valve | 20-Rear Service Brake Inspection Port (2 used) |
| 6-Front Axle Service Brake-to-Service Brake Valve Line | 13-Service Brake Accumulator (2 used) | 21-Rear Axle Breather |
| 7-Front Differential Lock-to-Hydraulic Pump Manifold Line | 14-Hydraulic Pump Manifold-to-Service Brake Accumulator Line | |
| | 15-Transmission | |

JL26034,000002D-19-20160720



Thank you very much
for your reading.
Please click here
to get more information.