

John Deere 7210R 7230R 7250R 7270R 7290R 7310R Tractor (SN.094000-) Repair Technical Manual TM146119

9450, 9550 and 9650 Combines Repair

REPAIR TECHNICAL MANUAL

Combines 9450, 9550, 9650 (S.N. 000000-695100)

TM1801 07 AUG 00 (ENGLISH)

For complete service information also see:

9450, 9550 and 9650 Combines Diagnosis TM1802

PowerTech 8.1 L Diesel Engines Base Engine CTM86

Alternators and Starting Motors CTM77

Electronic Fuel Injection Systems CTM68

OEM Engine Accessories CTM67

PowerTech 6.8L and 8.1L 606 Diesel Engines (I) Systems with Bo CTM134

PowerTech 4.5L and 6.0L (I) 1/Stage I, Tier 2/Stage II, Tier 3/Stage IIA Tier 3/Stage IIB (I) Engine)



DOWNLOAD



John Deere Agriculture

Covers: 094000(❖❖❖❖❖❖❖);,7210R,7230R,7250R,7270R,7290R,7310R

Type: Service Manual

Language: English

Pages: 1225

Format: PDF

Features: Bookmarked, searchable, printable

Compatibility: Windows/Mac/Tablet/Mobile

This service manual contains important information for the maintenance, troubleshooting and servicing of the **John Deere 7210R 7230R 7250R 7270R 7290R 7310R Tractor (SN.094000-) Repair Technical Manual TM146119**

In this manual you will find detailed specifications, illustrations, schematics, diagrams and step-by-step procedures to properly service and diagnose the machine to the manufacturer's standards.

Contents:

- General Information
- Specifications
- Serial Number Location
- Engine Specifications
- Engine Diagnostics
- Engine Tests and Adjustments
- Engine Repair
- Power Train
- Transmission
- Axles
- Differential
- PTO
- Hydraulic System
- Electrical System
- Electrical Tests and Diagnostics
- Wiring Diagram / Schematic
- Ignition and Charging
- Steering
- Brakes
- Wheels
- Operator's Platform
- Body Panels
- Disassembly and Assembly
- Diagnostics, Tests and Adjustments
- Troubleshooting
- and much more...

Please note this manual is in **downloadable PDF format only**. If you have any questions about this product or would like to request sample pages, please contact us and reference the product name or SKU.

Engine Gear Case Specifications

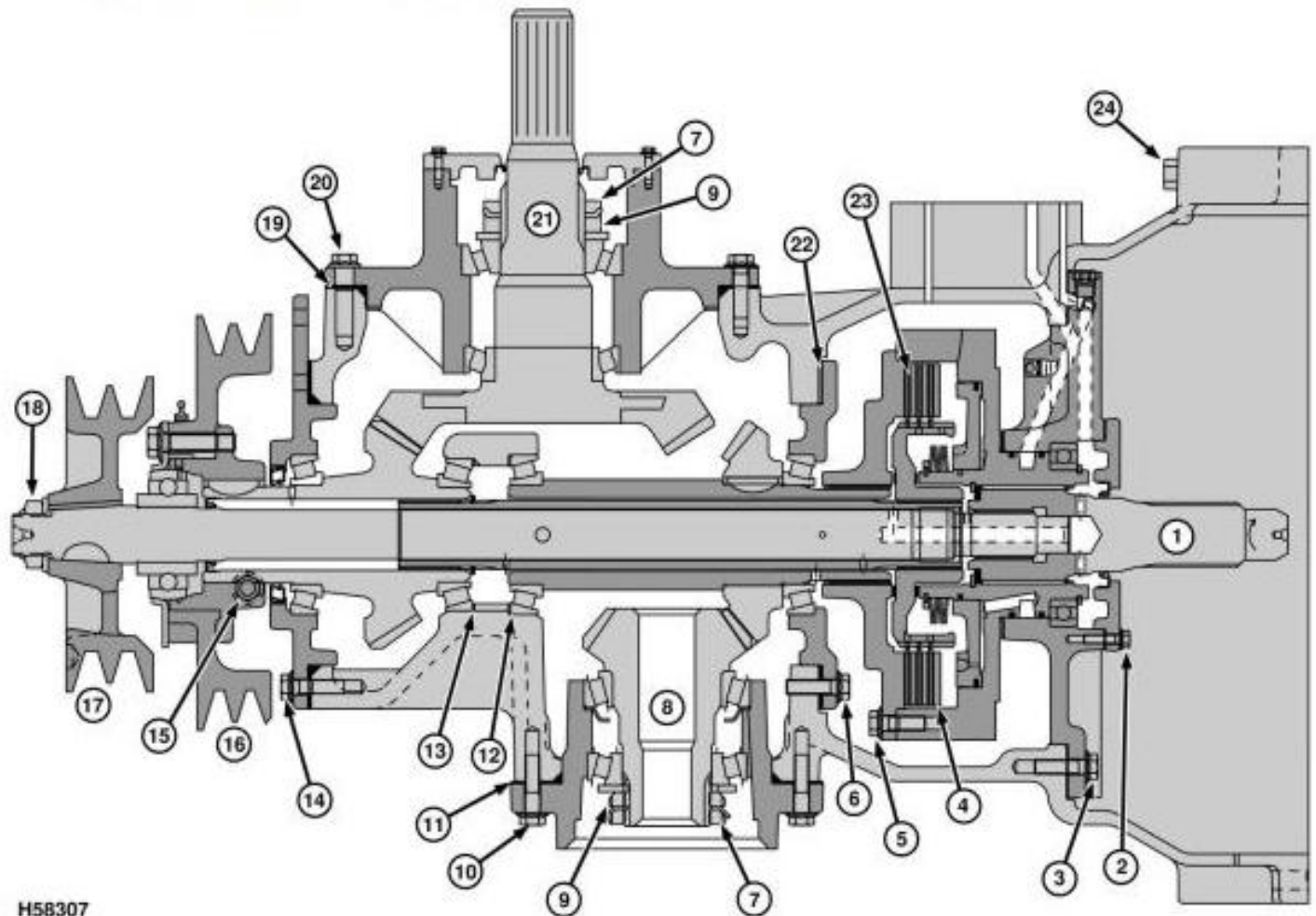

H58307

Engine Gear Case

LEGEND:

1	Power From Engine
2	15 N-m (144 lb-in.)
3	50 N-m (40 lb-ft)
4	Wet Clutch Disk (3 used)
5	75 N-m (55 lb-ft)
6	50 N-m (40 lb-ft)
7	70 N-m (50 lb-ft) with zero end play
8	Power to Pumps
9	0.38 mm (0.015 in.) end play + 1/4 turn to preload
10	50 N-m (40 lb-ft)
11	Shims-Gear Backlash
12	Shims-Gear Position
13	Shims-Gear Position
14	50 N-m (40 lb-ft)
15	75 N-m (55 lb-ft)
16	Straw Chopper Drive
17	Unloading Drive
18	340 N-m (250 lb-ft)
19	Shims-Gear Backlash
20	50 N-m (40 lb-ft)
21	Separator Drive
22	Shims-Preload Bearings
23	Wet Clutch Plate (3 used)
24	340 N-m (250 lb-ft)



Thank you very much
for your reading.
Please click here
to get more information.