

John Deere 725D, 730D, 735D and 740D Draper Platforms Repair Technical Service Manual (TM148919)

725D, 730D, 735D and
740D Draper Platforms
Repair



JOHN HARE



COLLECTION

REPAIR TECHNICAL MANUAL
725D, 730D, 735D and 740D Draper Platforms

TM148919 01DEC18 (ENGLISH)



John Deere Harvester Works

Covers: 725D,730D,735D,740D

Type: Service Manual

Language: English

Pages: 240

Format: PDF

Features: Bookmarked, searchable, printable

Compatibility: Windows/Mac/Tablet/Mobile

This service manual contains important information for the maintenance, troubleshooting and servicing of the **John Deere 725D, 730D, 735D and 740D Draper Platforms Repair Technical Service Manual (TM148919)**

In this manual you will find detailed specifications, illustrations, schematics, diagrams and step-by-step procedures to properly service and diagnose the machine to the manufacturer's standards.

Contents:

- General Information
- Specifications
- Serial Number Location
- Engine Specifications
- Engine Diagnostics
- Engine Tests and Adjustments
- Engine Repair
- Power Train
- Transmission
- Axles
- Differential
- PTO
- Hydraulic System
- Electrical System
- Electrical Tests and Diagnostics
- Wiring Diagram / Schematic
- Ignition and Charging
- Steering
- Brakes
- Wheels
- Operator's Platform
- Body Panels
- Disassembly and Assembly
- Diagnostics, Tests and Adjustments
- Troubleshooting
- and much more...

Please note this manual is in **downloadable PDF format only**. If you have any questions about this product or would like to request sample pages, please contact us and reference the product name or SKU.

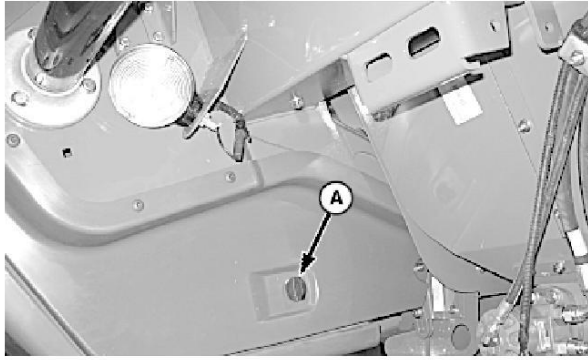

6. H91268-UN: Shield

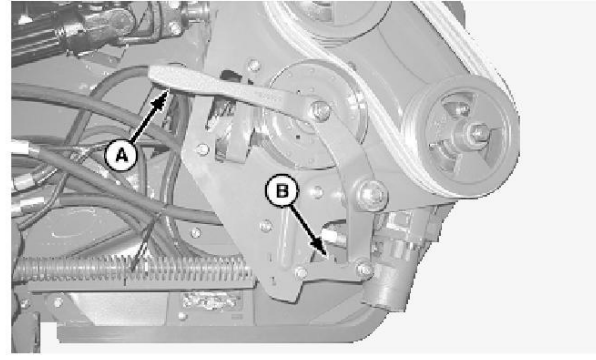

9. H91578-UN: Idler Arm Lock Out

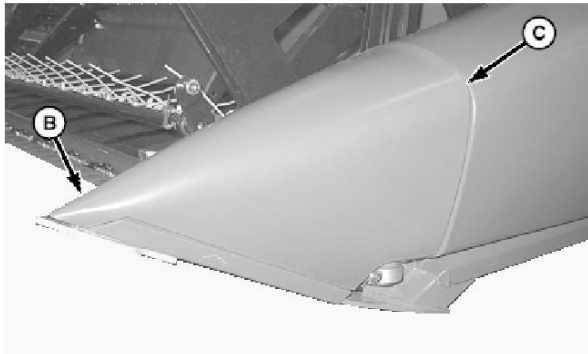

H91269-UN: Left-Hand Row Divider

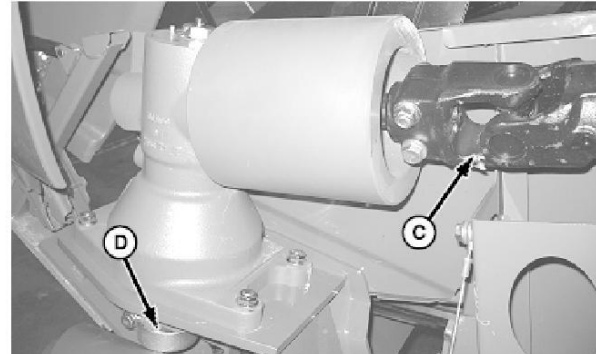

H91579-UN: Drive Coupler

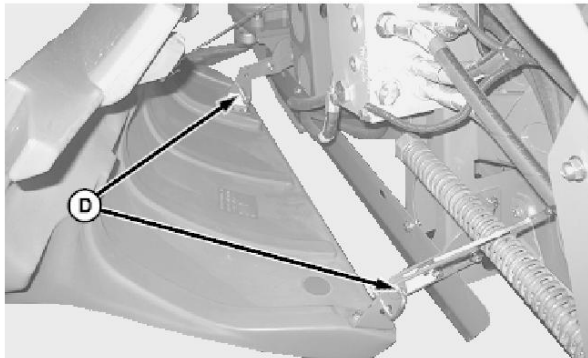

H91270-UN: Latch

LEGEND:

A-Knob

B-Front of Left-Hand Row Divider

C-Back of Left-Hand Row Divider

D-Latch (2 used)

Turn knob (A) counterclockwise and open left-hand end shield.

7. Lift up at front of left-hand row divider (B) and then at back of left-hand row divider (C).
8. Unhook latches (D) and remove middle shield.

LEGEND:

A-Idler Arm

B-Idler Arm Lock Out

C-Yoke

D-Knife Assembly

Pull down on idler arm (A) to release tension on knife drive belts.

10. Place idler arm lock out (B) into position supporting idler arm.
11. Place a pry bar or large screwdriver in yoke (C) and turn drive shaft moving knife assembly (D).
12. Knife assembly (D) should move easily. If drive shaft does not move easily or knife binds during movement, adjust knife head and knife drive alignment.

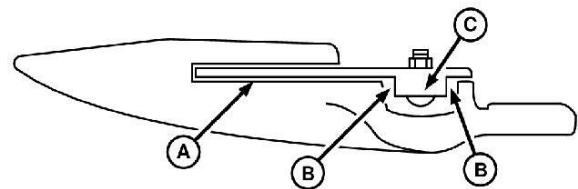

13. H91585-UN: Gaps

LEGEND:

A-Gap

B-Gap (Two Locations)

C-Knife Back

Visually inspect the positions (A and B) of the knife section in the first knife guard slot and knife back (C) fore/aft position in the guard. If there is excessive contact in either location, adjust knife head and knife drive alignment.



Thank you very much
for your reading.
Please click here
to get more information.