

John Deere 770G, 770GP, 772G, 772GP (SN.C678818◆◆◆◆◆◆◆◆680877) Motor Graders Repair Manual (TM14079X19)

F441M, F441R Round
Baler Repair



JOHN HARE



COLLECTION

REPAIR TECHNICAL MANUAL
F441M, F441R Round Balers

TM301619 01DEC18 (ENGLISH)

For complete service information also see:

F441M, F441R Round Baler Diagnostic..... TM301519



John Deere Arc-les-Gray

Covers: 770G,770GP,1DW770G_.,_C678818◆◆◆◆◆◆◆◆680877;;1DW770G_.,_D6

Type: Service Manual

Language: English

Pages: 430

Format: PDF

Features: Bookmarked, searchable, printable

Compatibility: Windows/Mac/Tablet/Mobile

This service manual contains important information for the maintenance, troubleshooting and servicing of the **John Deere 770G, 770GP, 772G, 772GP (SN.C678818◆◆◆◆◆◆680877) Motor Graders Repair Manual (TM14079X19)**

In this manual you will find detailed specifications, illustrations, schematics, diagrams and step-by-step procedures to properly service and diagnose the machine to the manufacturer's standards.

Contents:

- General Information
- Specifications
- Serial Number Location
- Engine Specifications
- Engine Diagnostics
- Engine Tests and Adjustments
- Engine Repair
- Power Train
- Transmission
- Axles
- Differential
- PTO
- Hydraulic System
- Electrical System
- Electrical Tests and Diagnostics
- Wiring Diagram / Schematic
- Ignition and Charging
- Steering
- Brakes
- Wheels
- Operator's Platform
- Body Panels
- Disassembly and Assembly
- Diagnostics, Tests and Adjustments
- Troubleshooting
- and much more...

Please note this manual is in **downloadable PDF format only**. If you have any questions about this product or would like to request sample pages, please contact us and reference the product name or SKU.

METRI PACK Connectors [For Metri Pack connectors, 150 series]

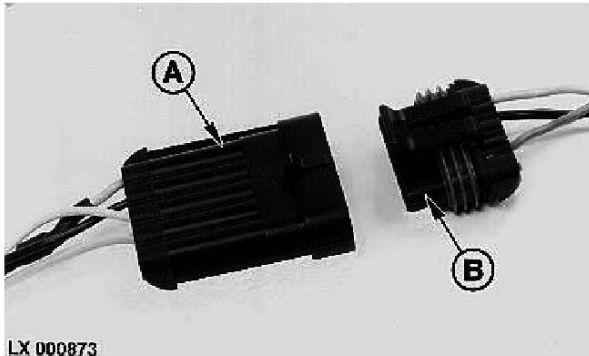

LX 000873

LX000873-UN: Metri Pack Connectors

LEGEND:

A-Male Terminal

B-Female Terminal

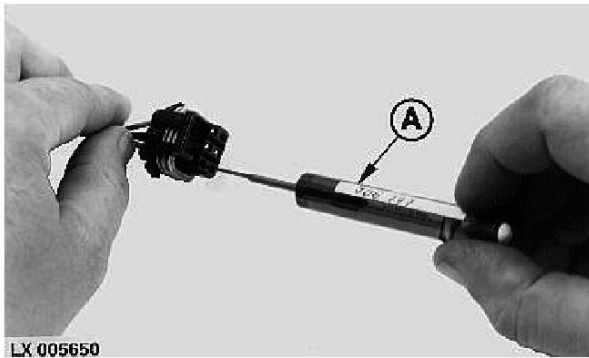

LX 005650

LX005650-UN: Use Pointed Tool to Remove Female Terminal

LEGEND:

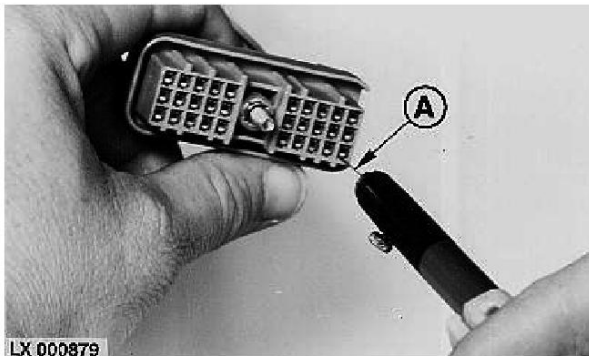
A-JDG777 Extraction Tool [For Metri Pack connectors, 150 series]
Remove Male or Female TerminalSee [JDG777 - Extraction Tool](#) in Section 199.

LX 000879

LX000879-UN: Use Pointed Tool to Remove Terminal

Remove a Female Terminal on Multiple-Pin Connectors for Electronic Units

Using a pointed tool (A), depress locking tang and pull out terminal.

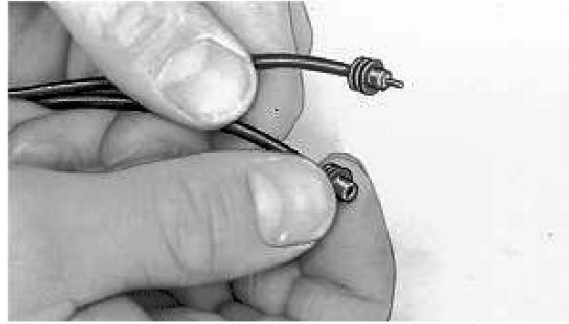

TS0136-UN: Install METRI PACK Male or Female Terminal

Install METRI PACK Male or Female Terminal

NOTE:

Wire seals are color coded for three sizes of wire:

Green - Wire size 0.75 mm²(18 to 20 AWG)

Grey - Wire size 1.5 mm²(14 to 16 AWG)

Blue - Wire size 4.0-6.0 mm²(10 to 12 AWG)

NOTE:

On multiple-pin connectors of electronic units, seal is installed in connector housing.

1. Slip correct size seal on wire.

IMPORTANT:

2. **The seal must fit snug over the wire insulation, without a gap between the seal and the insulation.**

Strip insulation from wire to expose 6 mm (1/4 in.) length of wire. Align seal with edge of insulation.

3. NOTE:

On multiple-pin connectors of electronic units, first insert wire through connector housing before crimping contact.

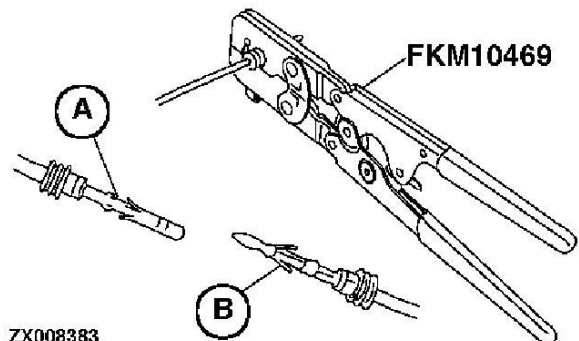

ZX008383

ZX008383-UN: Put Proper Size Contact on Wire and Crimp

Put proper size contact (A) or (B) on wire and crimp in place, using crimping pliers FKM10469. See [FKM10469 - Crimping Pliers](#) in Section 199.



Thank you very much
for your reading.
Please click here
to get more information.