

John Deere 824K Series II (SN.from F664579) Diagnostic, Operation & Test Service Manual (TM13220X19)

**524K-II 4WD Loader
Operation and Test**
(PIN: 1BZ524KA__D001001—)



JOHN HARE



COLLECTION

OPERATION & TEST TECHNICAL MANUAL
524K-II 4WD Loader (PIN: 1BZ524KA__D001001—)

TM14197X19 01DEC18 (ENGLISH)

For complete service information also see:

PowerTech E 4.5 and 6.8L Diesel Engines Level 16 Electronic Fuel System With Denso HPCR.....	ctm502
524K-II 4WD Loader Repair.....	TM14200X19
TeamMate™ IV 1200 Series Inboard Planetary Axles	ctm140119
PowerTech 4.5L & 6.8L Diesel Engines Tier 1/2/Stage II, Tier 3/Stage III (Base Engine).....	ctm140119
PowerTech 4045, 6065 Diesel Fuel System with the Denso (HPCR) Level 14 ECU.....	ctm140119



Worldwide Construction and
Forestry Division

Covers: 824K-II, 1DW824K***F664579 (7 icons)

Type: Service Manual

Language: English

Pages: 1503

Format: PDF

Features: Bookmarked, searchable, printable

Compatibility: Windows/Mac/Tablet/Mobile

This service manual contains important information for the maintenance, troubleshooting and servicing of the **John Deere 824K Series II (SN.from F664579) Diagnostic, Operation & Test Service Manual (TM13220X19)**

In this manual you will find detailed specifications, illustrations, schematics, diagrams and step-by-step procedures to properly service and diagnose the machine to the manufacturer's standards.

Contents:

- General Information
- Specifications
- Serial Number Location
- Engine Specifications
- Engine Diagnostics
- Engine Tests and Adjustments
- Engine Repair
- Power Train
- Transmission
- Axles
- Differential
- PTO
- Hydraulic System
- Electrical System
- Electrical Tests and Diagnostics
- Wiring Diagram / Schematic
- Ignition and Charging
- Steering
- Brakes
- Wheels
- Operator's Platform
- Body Panels
- Disassembly and Assembly
- Diagnostics, Tests and Adjustments
- Troubleshooting
- and much more...

Please note this manual is in **downloadable PDF format only**. If you have any questions about this product or would like to request sample pages, please contact us and reference the product name or SKU.

System Functional Schematic (SE5-SE6)

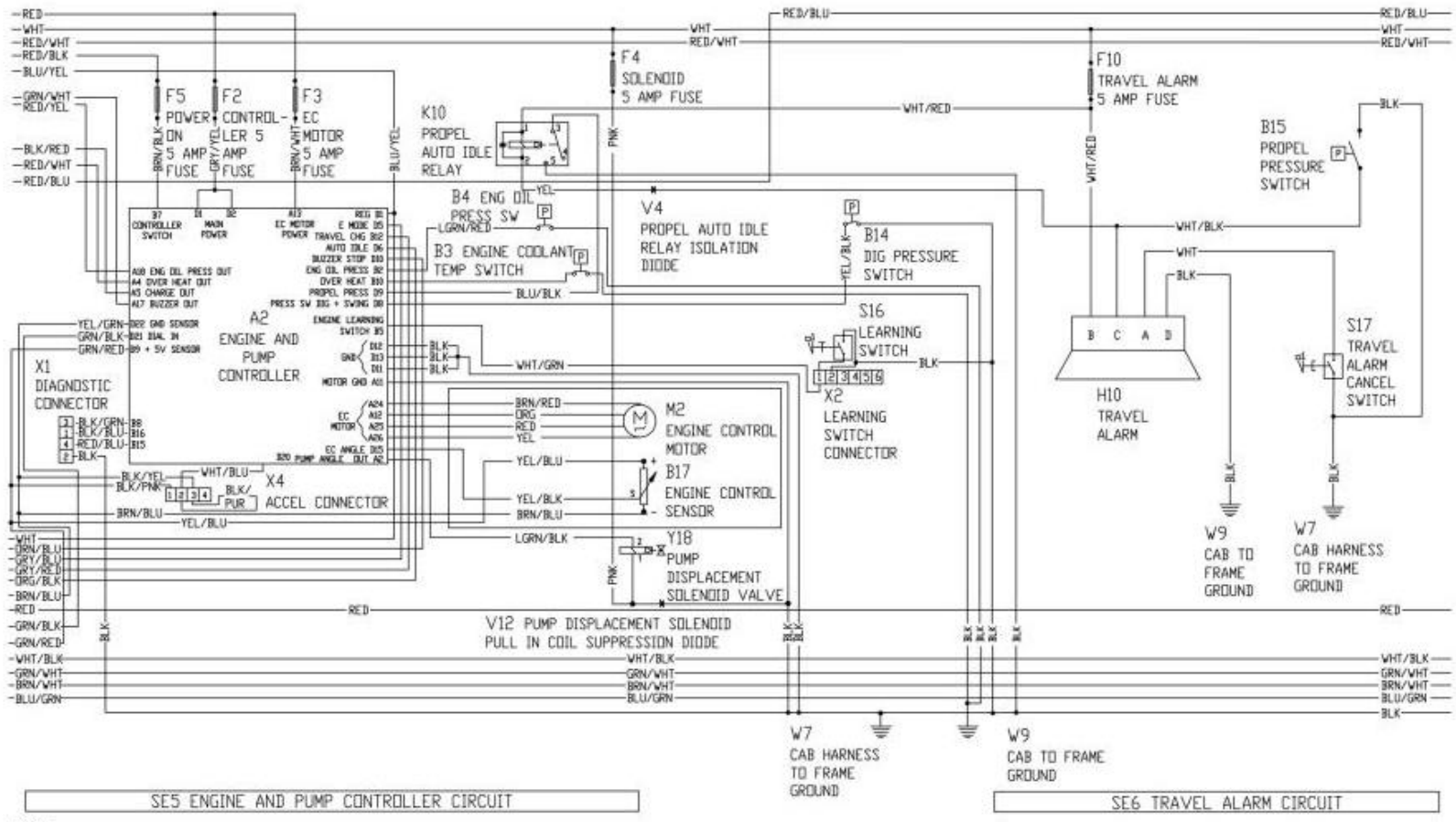

T136901

Engine and Pump Controller and Travel Alarm Circuits (SE5-SE6)



Thank you very much
for your reading.
Please click here
to get more information.