

# John Deere 903M,953M,959M (SN.C317982-,D317982-) Feller Buncher Diagnostic Service Manual TM14263X19



326E Skid Steer Loader  
with EH Controls  
Diagnostic



**OPERATION AND TEST MANUAL**  
**IT4/S3A models 326E (PIN: 1T0326E\*\*\*G254998-)**  
TM13090X19 21 OCT 15 (ENGLISH)

**For complete service information also see:**

326E Skid Steer Loader (EH Controls) Repair	TM13093X19
Yanmar 4TNV98 and 4TNV98T Diesel Engines (Interim Tier 4/Stage IIIB platform)	CTM130319
120 Series Hydraulic Cylinders	CTM120519

  **DOWNLOAD** 

John Deere Construction and Forestry  
Printed by Belgreen



TM13090X19

Covers: 903M,1T0903MX\_,\_C317982;1T0903MX\_,\_D317982

**Type:** Service Manual

**Language:** English

**Pages:** 829

**Format:** PDF

**Features:** Bookmarked, searchable, printable

**Compatibility:** Windows/Mac/Tablet/Mobile

This service manual contains important information for the maintenance, troubleshooting and servicing of the **John Deere 903M,953M,959M (SN.C317982-,D317982-) Feller Buncher Diagnostic Service Manual TM14263X19**

In this manual you will find detailed specifications, illustrations, schematics, diagrams and step-by-step procedures to properly service and diagnose the machine to the manufacturer's standards.

**Contents:**

- General Information
- Specifications
- Serial Number Location
- Engine Specifications
- Engine Diagnostics
- Engine Tests and Adjustments
- Engine Repair
- Power Train
- Transmission
- Axles
- Differential
- PTO
- Hydraulic System
- Electrical System
- Electrical Tests and Diagnostics
- Wiring Diagram / Schematic
- Ignition and Charging
- Steering
- Brakes
- Wheels
- Operator's Platform
- Body Panels
- Disassembly and Assembly
- Diagnostics, Tests and Adjustments
- Troubleshooting
- and much more...

Please note this manual is in **downloadable PDF format only**. If you have any questions about this product or would like to request sample pages, please contact us and reference the product name or SKU.

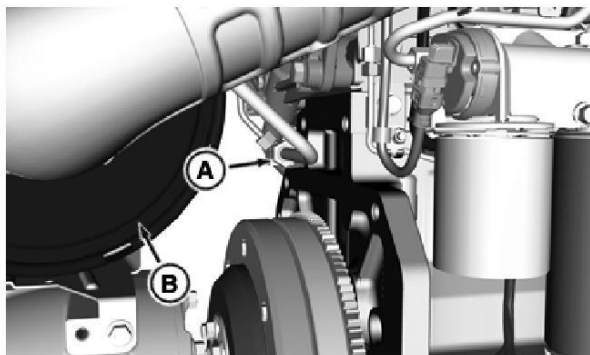

20. RXA0139863-UN: Heater Line

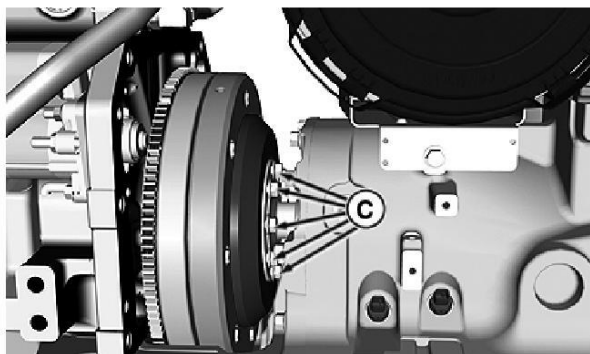

RXA0139864-UN: Drive Coupler

**LEGEND:**

**A-Heater Manifold Fitting**

**B-Air Cleaner**

**C-Drive Coupler Cap Screws (9 used)**

Disconnect line from heater manifold fitting (A) and remove fitting from block.

21. Remove air cleaner (B).

22. Remove cap screws (C) using JDG820 Flywheel Rotation Tool and disconnect drive coupler.

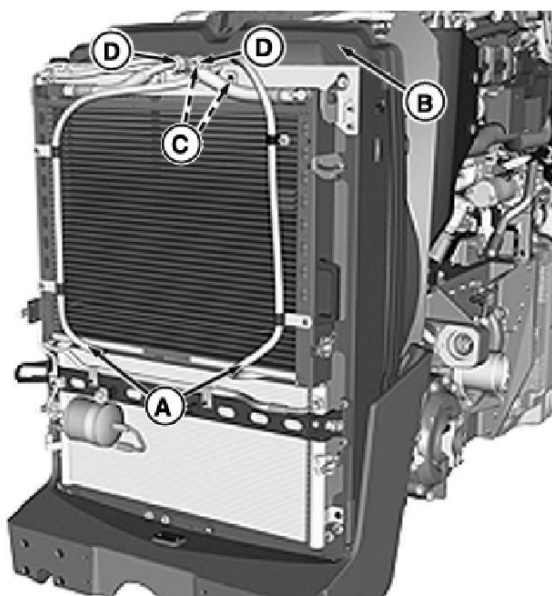

23. RXA0140458-UN: Fuel Lines and Radiator Supports

**LEGEND:**

**A-Fuel Cooler Hoses (2 used)**

**B-Top Radiator Seal**

**C-Line Clamp Cap Screws (2 used)**

**D-Hydraulic Oil Cooler Hoses (2 used)**

Disconnect fuel cooler hoses (A). Plug and cap all hoses and lines to prevent contamination.

24. Remove top radiator seal (B).

25. Remove line clamp cap screws (C).

26. Disconnect hydraulic oil cooler hoses (D). Plug hoses and cap lines to prevent contamination.

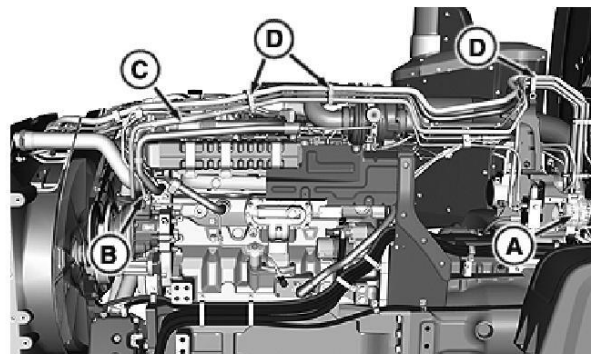

27. RXA0140463-UN: Line Bundle

**LEGEND:**

**A-Alternator**

**B-Fan Drive Oil Line**

**C-Front Heater Hose**

**D-Line Bundle Clamps (3 used)**

Remove alternator (A).

28. Disconnect fan drive oil line (B). Plug and cap line.

29. Disconnect front heater hose (C).

**IMPORTANT:**

30. If line bundle must be moved, take care to **NOT** take bundle clamps apart or move lines. Orientation of lines is specific and should not be disturbed.

Remove line bundle clamps (D).

31. Remove engine fan and position forward.

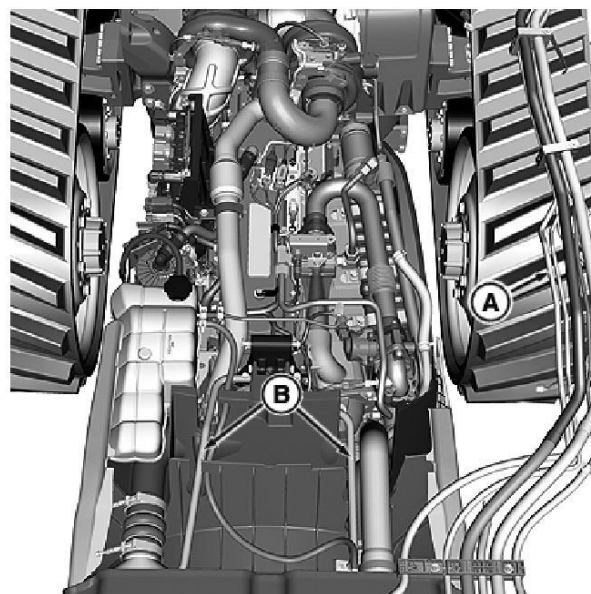

32. RXA0140462-UN: Line Bundle Moved

**LEGEND:**

**A-Line Bundle**

**B-Radiator Support Rods (2 used)**

Tilt entire line bundle (A) to left-hand side of tractor.

33. Remove radiator support rods (B).



Thank you very much  
for your reading.  
Please click here  
to get more information.