

John Deere 903M, 953M, 959M (SN.F317982-,L317982-) Tracked Feller Buncher Repair Manual (TM14262X19)

380GLC Excavator Repair

REPAIR TECHNICAL MANUAL
380GLC (PIN: 1FF380GX_ F900006-)
TM13205X19 21OCT15 (ENGLISH)

For complete service information also see:

380GLC Excavator Diagnostic	TM13204X19
JDLink (MTG) Technical Manual	TM114519
6090 PowerTech OEM Diesel Engines (Final Tier 4/Stage IV platform)	CTM117719



John Deere Construction and Forestry

Type: Service Manual

Language: English

Pages: 327

Format: PDF

Features: Bookmarked, searchable, printable

Compatibility: Windows/Mac/Tablet/Mobile

This service manual contains important information for the maintenance, troubleshooting and servicing of the **John Deere 903M, 953M, 959M (SN.F317982-,L317982-) Tracked Feller Buncher Repair Manual (TM14262X19)**

In this manual you will find detailed specifications, illustrations, schematics, diagrams and step-by-step procedures to properly service and diagnose the machine to the manufacturer's standards.

Contents:

- General Information
- Specifications
- Serial Number Location
- Engine Specifications
- Engine Diagnostics
- Engine Tests and Adjustments
- Engine Repair
- Power Train
- Transmission
- Axles
- Differential
- PTO
- Hydraulic System
- Electrical System
- Electrical Tests and Diagnostics
- Wiring Diagram / Schematic
- Ignition and Charging
- Steering
- Brakes
- Wheels
- Operator's Platform
- Body Panels
- Disassembly and Assembly
- Diagnostics, Tests and Adjustments
- Troubleshooting
- and much more...

Please note this manual is in **downloadable PDF format only**. If you have any questions about this product or would like to request sample pages, please contact us and reference the product name or SKU.

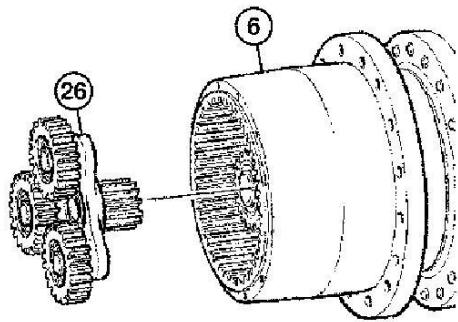

6. TX1026690-UN: Second Planetary Carrier Assembly

LEGEND:

6-Gear Case Housing

26-Second Planetary Carrier Assembly

Remove second planetary carrier assembly (26).

8.  **CAUTION:**
Prevent possible crushing injury from heavy component. Use appropriate lifting device.

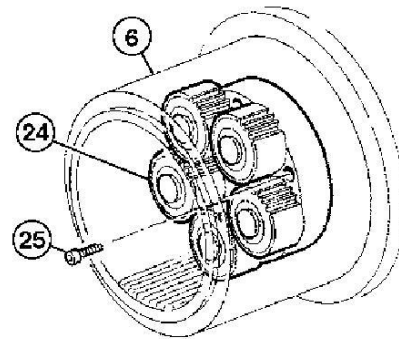

TX1026692-UN: Third Planetary Carrier Assembly

LEGEND:

6-Gear Case Housing

24-Third Planetary Carrier Assembly

25-Cap Screw (5 used)

Attach appropriate lifting device to third planetary carrier assembly (24). Remove cap screws (25) and remove third planetary carrier from gear case housing (6).

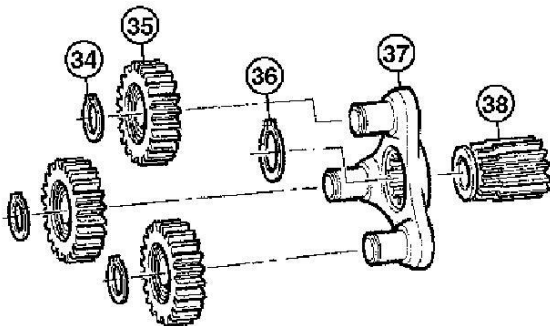

7. TX1029063-UN: Second Planetary Carrier

LEGEND:

34-Snap Ring (3 used)

35-Planet Gear (3 used)

36-Snap Ring

37-Second Planetary Carrier

38-Sun Gear

Disassemble second planetary carrier (37) as shown.

Item	Measurement	Specification
Third Planetary Carrier Assembly (U7 Track)	Weight (approximate)	46 kg 101 lb.
Third Planetary Carrier Assembly (U7 Extreme Duty Track)	Weight (approximate)	61 kg 135 lb.

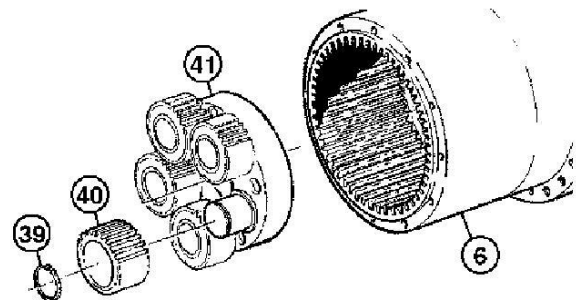

9. TX1029066-UN: Third Planetary Carrier

LEGEND:

6-Gear Case Housing

39-Snap Ring

40-Planet Gear (5 used)

41-Third Planetary Carrier

Disassemble third planetary carrier (41) as shown.



Thank you very much
for your reading.
Please click here
to get more information.