

John Deere / Bauer DB50, DB74, DB90 (SN.750101-) Planters Service Repair Technical Manual (TM803619)

Section 10 - GENERAL

Group 00: Identification View and Description

Assembly Designations

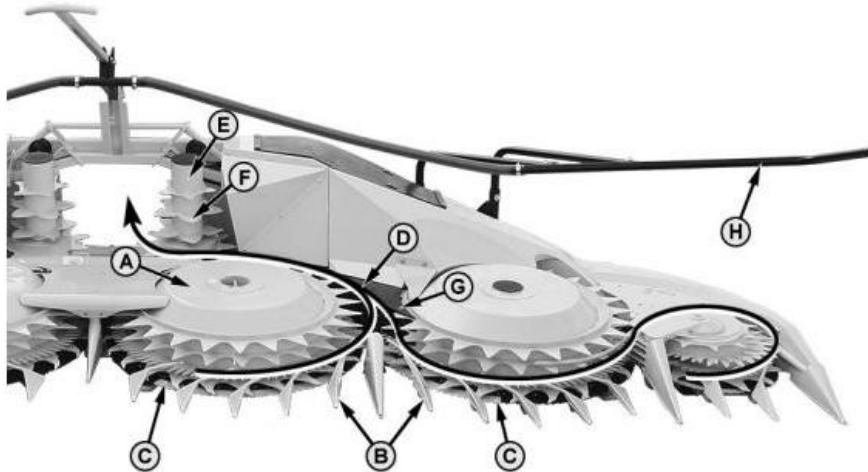

KM1000813

Assembly Designations

LEGEND:

A	Gathering Drum
B	Dividers
C	Rotating Blade
D	Lengthwise Direction of Crop
E	Feed Drum
F	Feed Teeth
G	Guides and Scrapers
H	Feed Bar

Hanging Points



KM1000805

Hanging Points

LEGEND:

PDF



DOWNLOAD



Type: Service Manual

Language: English

Pages: 443

Format: PDF

Features: Bookmarked, searchable, printable

Compatibility: Windows/Mac/Tablet/Mobile

This service manual contains important information for the maintenance, troubleshooting and servicing of the **John Deere / Bauer DB50, DB74, DB90 (SN.750101-) Planters Service Repair Technical Manual (TM803619)**

In this manual you will find detailed specifications, illustrations, schematics, diagrams and step-by-step procedures to properly service and diagnose the machine to the manufacturer's standards.

Contents:

- General Information
- Specifications
- Serial Number Location
- Engine Specifications
- Engine Diagnostics
- Engine Tests and Adjustments
- Engine Repair
- Power Train
- Transmission
- Axles
- Differential
- PTO
- Hydraulic System
- Electrical System
- Electrical Tests and Diagnostics
- Wiring Diagram / Schematic
- Ignition and Charging
- Steering
- Brakes
- Wheels
- Operator's Platform
- Body Panels
- Disassembly and Assembly
- Diagnostics, Tests and Adjustments
- Troubleshooting
- and much more...

Please note this manual is in **downloadable PDF format only**. If you have any questions about this product or would like to request sample pages, please contact us and reference the product name or SKU.

Gear Box, Exploded View (Part 1)

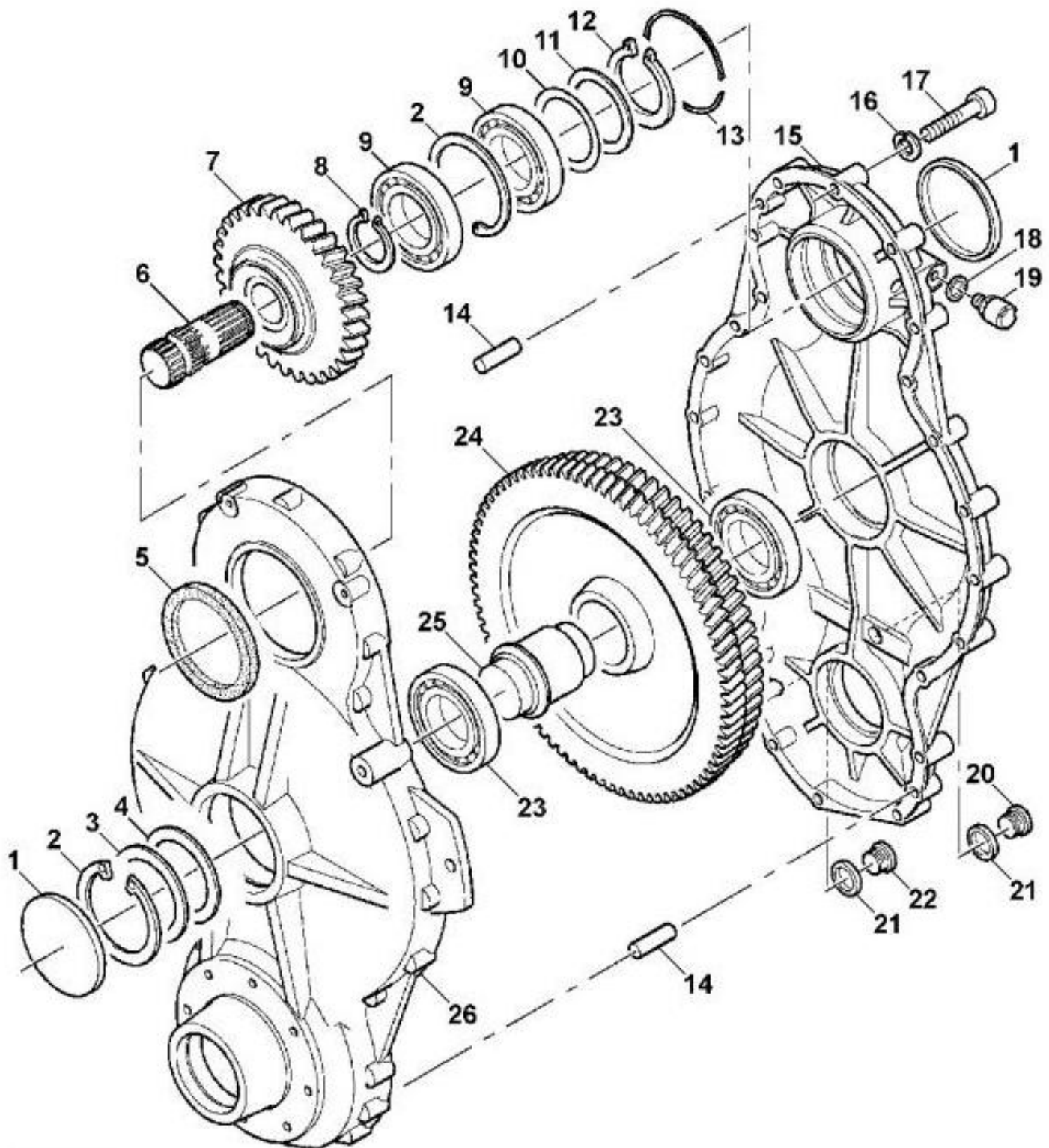

KM1000707

Exploded view of gear box

LEGEND:

1	Cap
2	Snap ring
3	Washer
4	Shim
5	Radial seal ring
6	Shaft
7	Spur gear
8	Snap ring



Thank you very much
for your reading.
Please click here
to get more information.