

# John Deere DN456, DN485 Dry Spinner Spreader Fertilize Sprayers Diagnostic Service Manual (TM128419)

**803M, 853M and 859M  
Tracked Feller Bunchers  
(Open-Loop Hydraulic  
Drive) Operation and  
Test**



(PIN: 1T0803MX\_\_F293917—;  
PIN: 1T0853MX\_\_F293917—;  
PIN: 1T0803MX\_\_L343918—;  
PIN: 1T0853MX\_\_L343918—)

JOHN HARE



COLLECTION

**OPERATION & TEST TECHNICAL MANUAL  
803M, 853M and 859M Tracked Feller Bunchers  
(Open-Loop Hydraulic Drive)**

(PIN: 1T0803MX\_\_F293917—; PIN: 1T0853MX\_\_F293917—;  
PIN: 1T0803MX\_\_L343918—; PIN: 1T0853MX\_\_L343918—)

TM14084X19 01DEC18 (ENGLISH)



For complete service information:

|  |            |
|--|------------|
| 6090 PowerTech™ OEM Diesel Engines (Final Tier 4/Stage IV platform).....             | ctm117719  |
| 803M, 853M and 859M Tracked Feller Bunchers (Open-Loop Hydraulic Drive) Repair ..... | TM14084X19 |
| Hydraulic Cylinders.....   | ctm120519  |
| FD220B, FS22B, FR22B, FR24B Disk Saw Felling Heads..                                 | tm10110    |
| FR21B Disk Saw Felling Heads.....  | tm11854    |

Worldwide Construction and  
Forestry Division

**Covers:** DN456, DN485

**Type:** Service Manual

**Language:** English

**Pages:** 420

**Format:** PDF

**Features:** Bookmarked, searchable, printable

**Compatibility:** Windows/Mac/Tablet/Mobile

This service manual contains important information for the maintenance, troubleshooting and servicing of the **John Deere DN456, DN485 Dry Spinner Spreader Fertilize Sprayers Diagnostic Service Manual (TM128419)**

In this manual you will find detailed specifications, illustrations, schematics, diagrams and step-by-step procedures to properly service and diagnose the machine to the manufacturer's standards.

**Contents:**

- General Information
- Specifications
- Serial Number Location
- Engine Specifications
- Engine Diagnostics
- Engine Tests and Adjustments
- Engine Repair
- Power Train
- Transmission
- Axles
- Differential
- PTO
- Hydraulic System
- Electrical System
- Electrical Tests and Diagnostics
- Wiring Diagram / Schematic
- Ignition and Charging
- Steering
- Brakes
- Wheels
- Operator's Platform
- Body Panels
- Disassembly and Assembly
- Diagnostics, Tests and Adjustments
- Troubleshooting
- and much more...

Please note this manual is in **downloadable PDF format only**. If you have any questions about this product or would like to request sample pages, please contact us and reference the product name or SKU.

## System Diagrams

Each electrical component is shown by a schematic symbol (8), the component name (6), and a component identification number (1). A component identification number and name will remain the same throughout the Operation and Test Technical Manual. This will allow for easy cross-referencing of all electrical drawings (Schematics, Wiring Diagrams, and Component Location).

Routing location information (2) is presented to let the reader know when a wire is connected to a component in another section. TO and FROM statements identify when power is going 'To' or coming 'From' a component in a different location. The section and component identification number are given in the first line of information and any pin information for the component is given in parenthesis in the second line. In this example, power is going TO section 23, component B14 on pin C4.

### Wiring Diagram

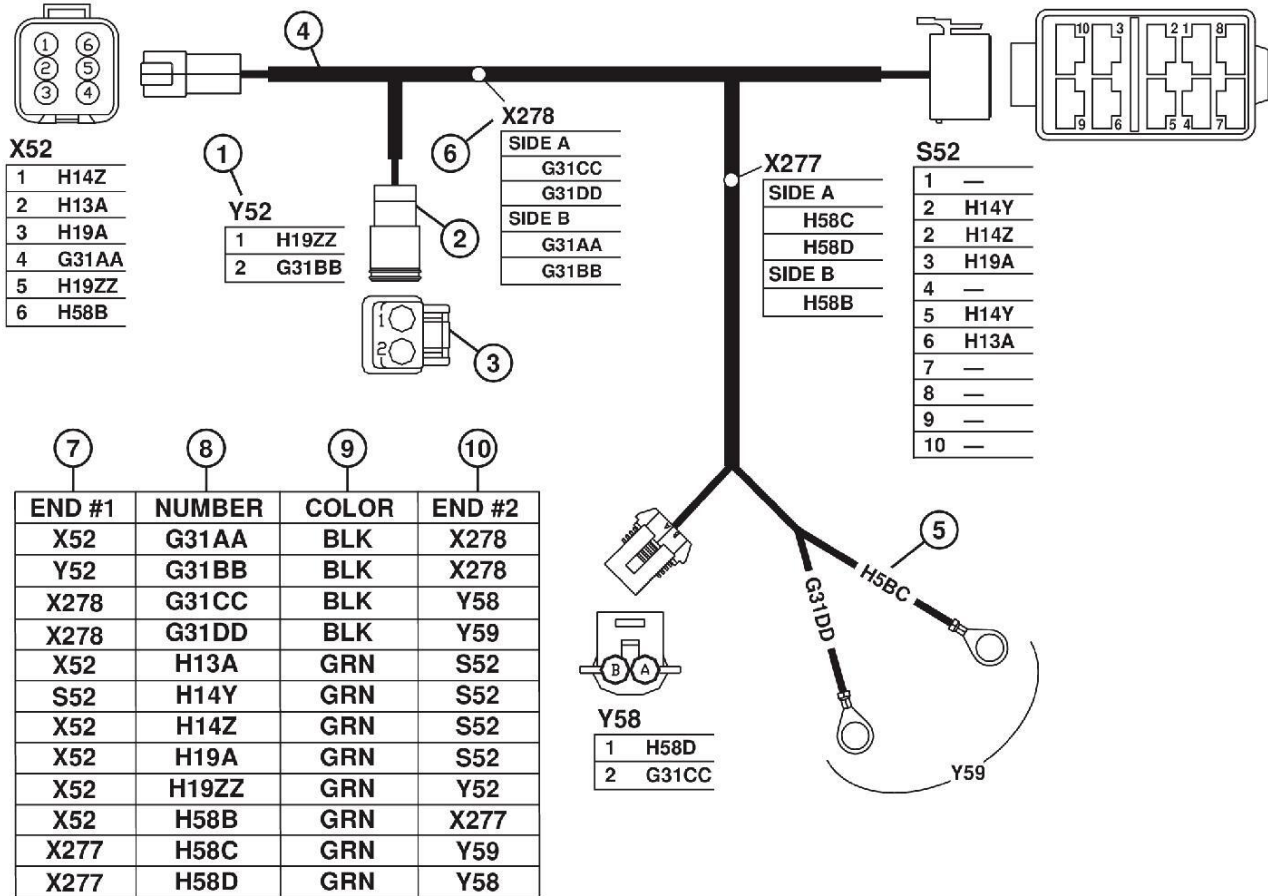

#### TX1020361

TX1020361-UN: Wiring Diagram Example

#### LEGEND:

- 1-Component Identification Number
- 2-Connector
- 3-Connector End View
- 4-Wire Harness
- 5-Wire Number
- 6-Wire Splice
- 7-Wire End #1 Termination Location
- 8-Wire Number
- 9-Wire Color
- 10-Wire End #2 Termination Location

Each harness on the machine is drawn showing connectors, wires, and splices. A 'W' component identification number identifies harnesses. (W6, Etc.) The harness is drawn showing spatial arrangement of components and branches.

A component identification or connector number (1) identifies each component. The harness branch (4) is terminated by a top or side view of the connector (2). If more than one wire is supplied to the connector, a harness side connector end view (3) is provided. Each wire number is labeled for the appropriate pin. If only one wire is supplied to the connector, the wire number (5) is indicated.

An 'X' component identification number of 100 or higher identifies splices (6). Each splice lists side A wires and side B wires to differentiate the side of the harness that the wires come from.

A wire legend is provided for each harness. A component identification number is listed in the 'END #1' column (7) to indicate the termination location of one end of a wire. In the center, the wire number (8) and wire color (9) are listed. A component identification number in the 'END #2' column (10) identifies the opposite end of the wire.



Thank you very much  
for your reading.  
Please click here  
to get more information.