

# John Deere SST15, SST16, SST18 Spin-Steer Lawn Tractors Technical Service Manual (tm1908)

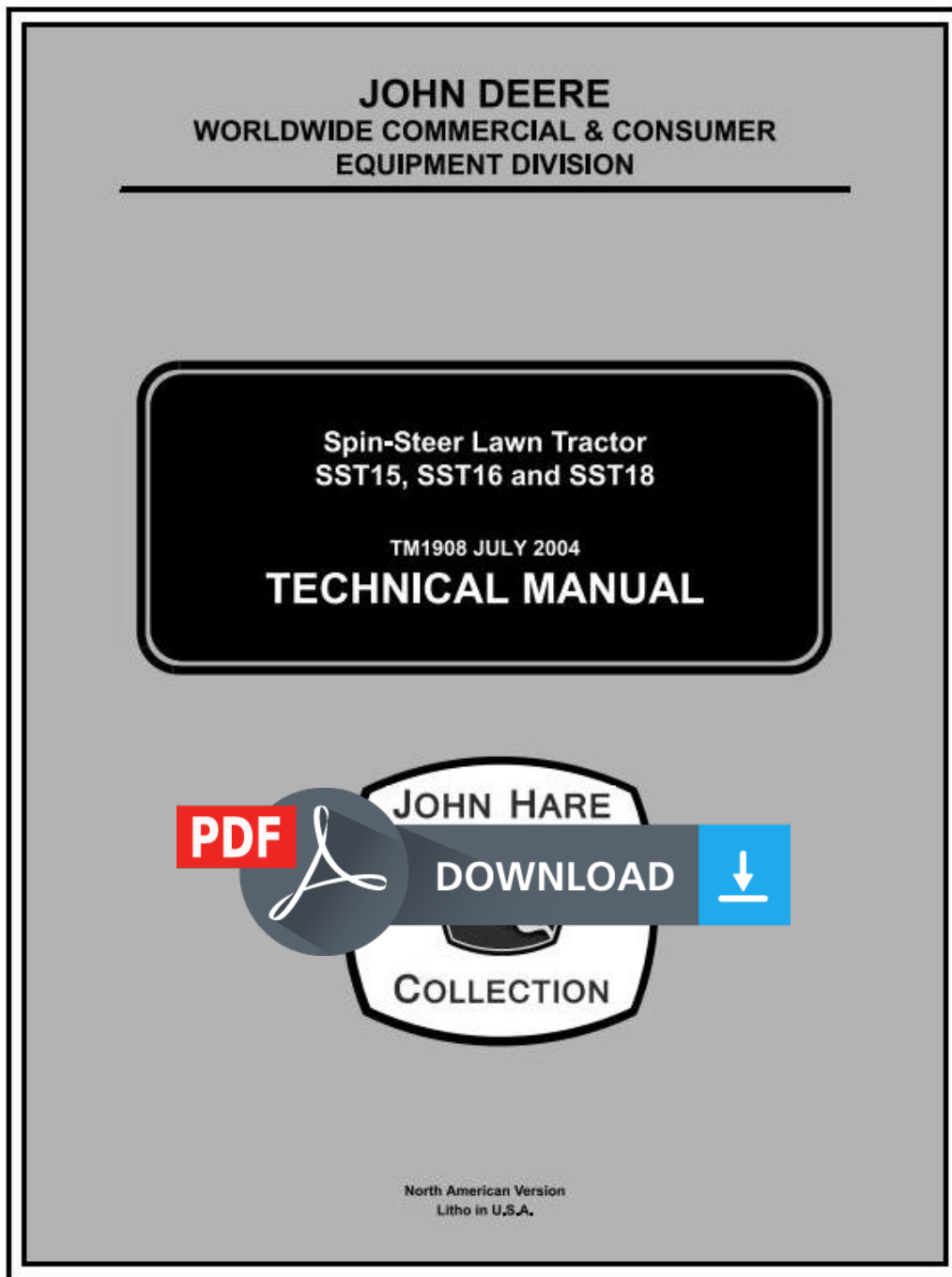

**Covers:** SST16,SST18,SST15

**Type:** Service Manual

**Language:** English

**Pages:** 330

**Format:** PDF

**Features:** Bookmarked, searchable, printable

**Compatibility:** Windows/Mac/Tablet/Mobile

This service manual contains important information for the maintenance, troubleshooting and servicing of the **John Deere SST15, SST16, SST18 Spin-Steer Lawn Tractors Technical Service Manual (tm1908)**

In this manual you will find detailed specifications, illustrations, schematics, diagrams and step-by-step procedures to properly service and diagnose the machine to the manufacturer's standards.

**Contents:**

- General Information
- Specifications
- Serial Number Location
- Engine Specifications
- Engine Diagnostics
- Engine Tests and Adjustments
- Engine Repair
- Power Train
- Transmission
- Axles
- Differential
- PTO
- Hydraulic System
- Electrical System
- Electrical Tests and Diagnostics
- Wiring Diagram / Schematic
- Ignition and Charging
- Steering
- Brakes
- Wheels
- Operator's Platform
- Body Panels
- Disassembly and Assembly
- Diagnostics, Tests and Adjustments
- Troubleshooting
- and much more...

Please note this manual is in **downloadable PDF format only**. If you have any questions about this product or would like to request sample pages, please contact us and reference the product name or SKU.

# ELECTRICAL DIAGNOSTICS & OPERATION

## Instrument Panel Electrical Schematic - SST18

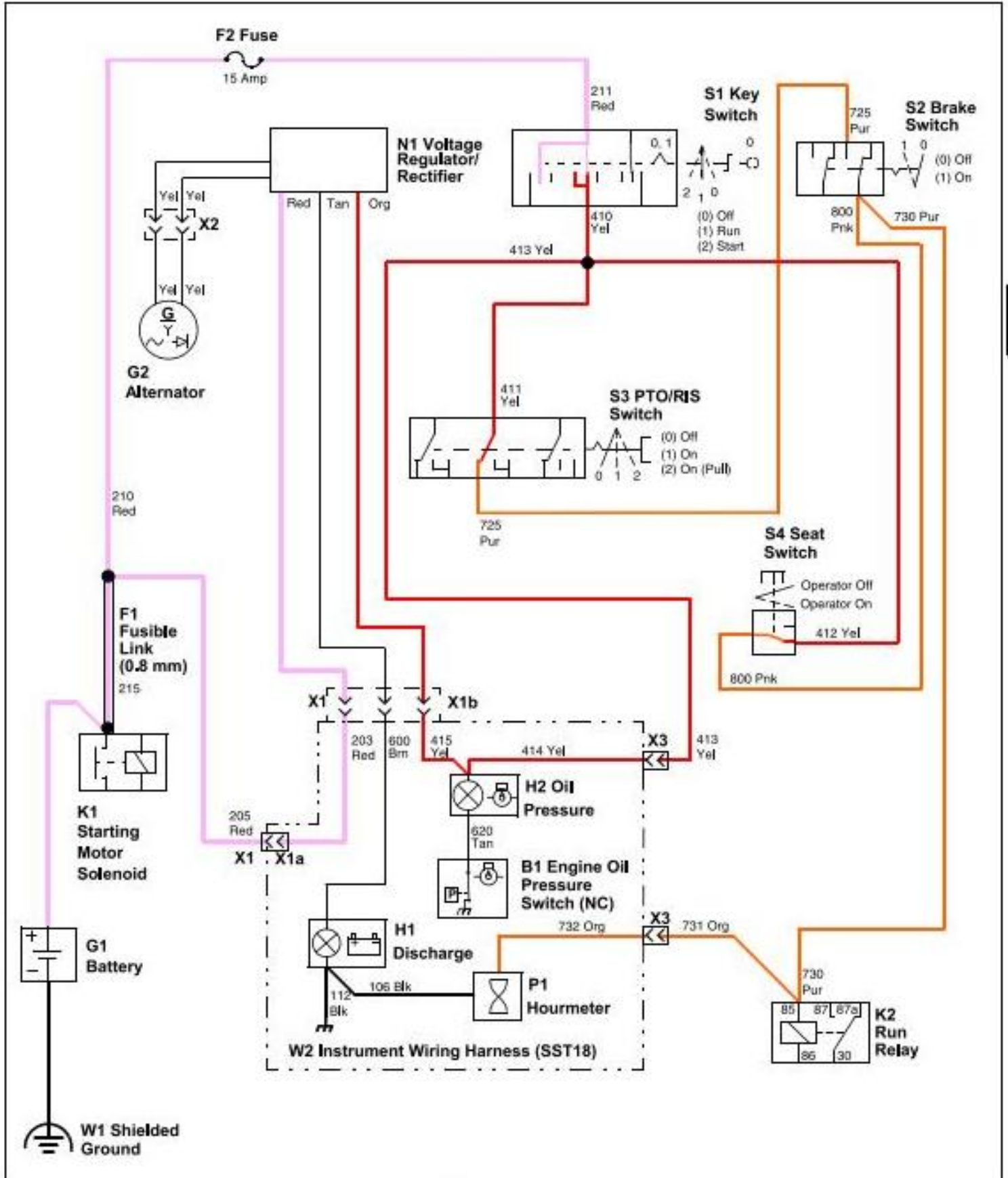

MIF



Thank you very much  
for your reading.  
Please click here  
to get more information.