

John Deere Tractors 6130, 6230, 6330, 6430, 6530, 6534, 6630 (European) Service Repair Manual (TM400519)

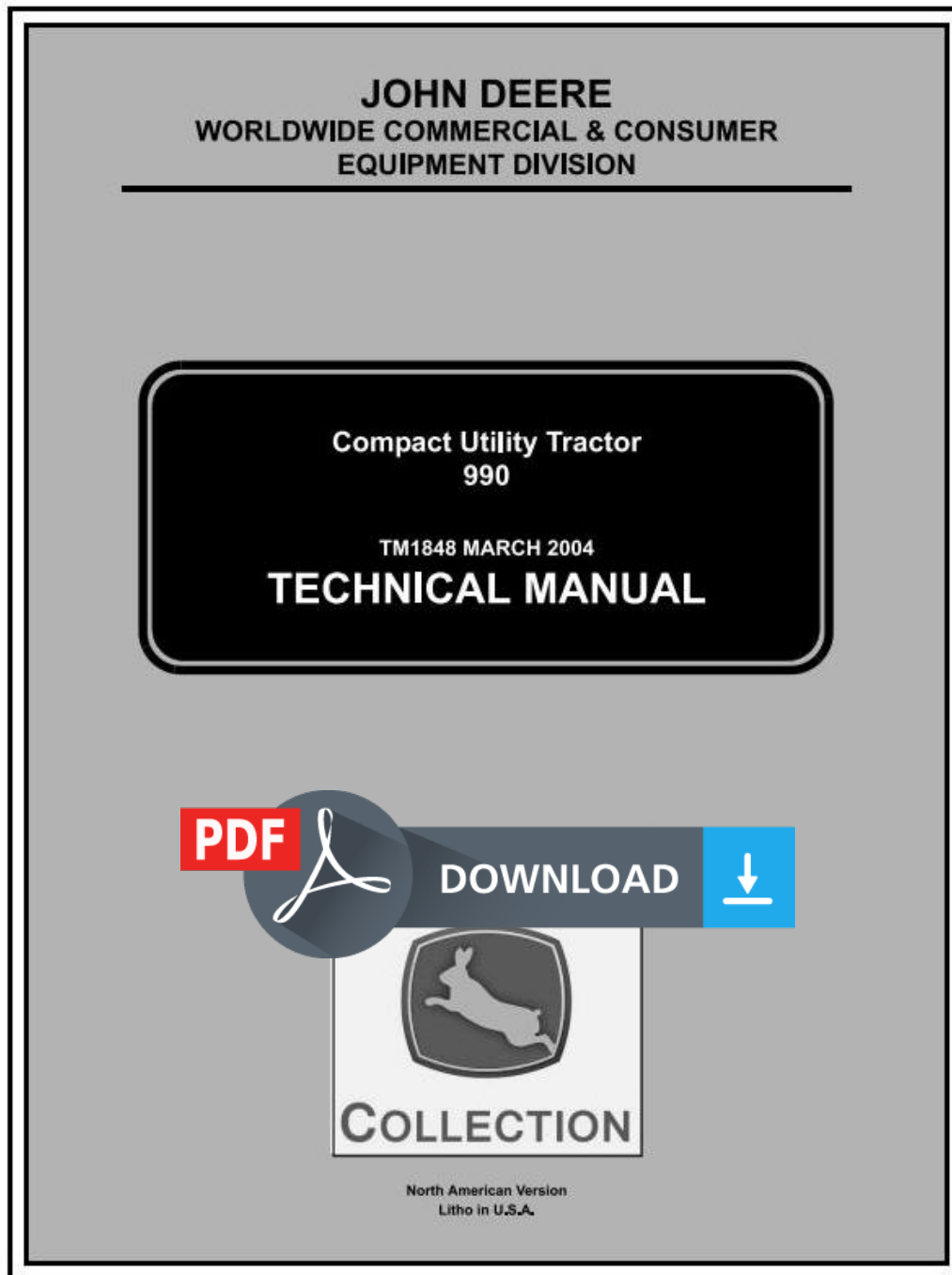

Covers: 6130,6230,6330,6430,6530,6630,6534

Type: Service Manual

Language: English

Pages: 2116

Format: PDF

Features: Bookmarked, searchable, printable

Compatibility: Windows/Mac/Tablet/Mobile

This service manual contains important information for the maintenance, troubleshooting and servicing of the **John Deere Tractors 6130, 6230, 6330, 6430, 6530, 6534, 6630 (European) Service Repair Manual (TM400519)**

In this manual you will find detailed specifications, illustrations, schematics, diagrams and step-by-step procedures to properly service and diagnose the machine to the manufacturer's standards.

Contents:

- General Information
- Specifications
- Serial Number Location
- Engine Specifications
- Engine Diagnostics
- Engine Tests and Adjustments
- Engine Repair
- Power Train
- Transmission
- Axles
- Differential
- PTO
- Hydraulic System
- Electrical System
- Electrical Tests and Diagnostics
- Wiring Diagram / Schematic
- Ignition and Charging
- Steering
- Brakes
- Wheels
- Operator's Platform
- Body Panels
- Disassembly and Assembly
- Diagnostics, Tests and Adjustments
- Troubleshooting
- and much more...

Please note this manual is in **downloadable PDF format only**. If you have any questions about this product or would like to request sample pages, please contact us and reference the product name or SKU.

ELECTRICAL THEORY OF OPERATION

Fuel Shutoff Circuit Schematic

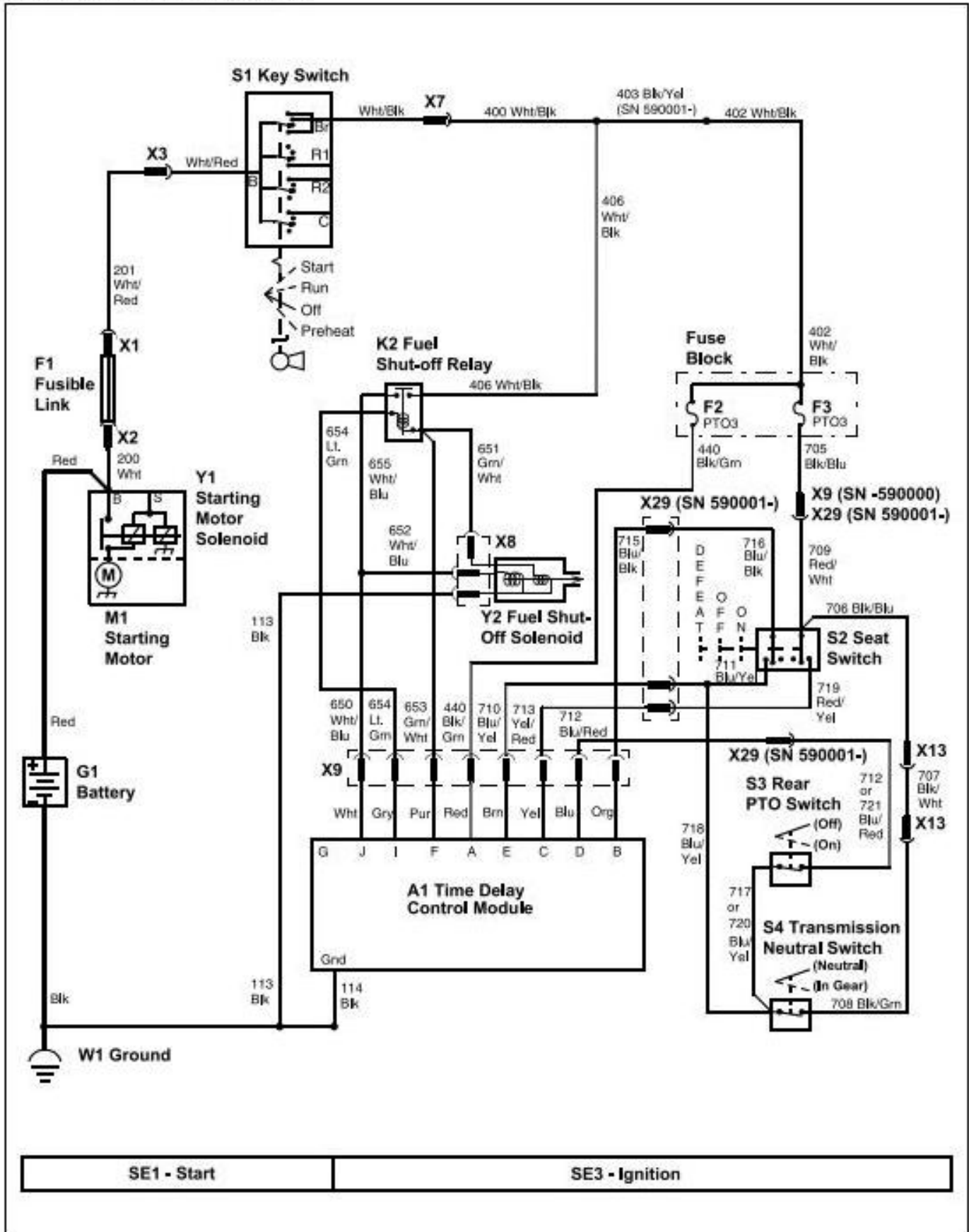



Thank you very much
for your reading.
Please click here
to get more information.