

John Deere Tractors Models 6415, 6615, 7515 (South America) Diagnostic and Tests Service Manual (TM8128)

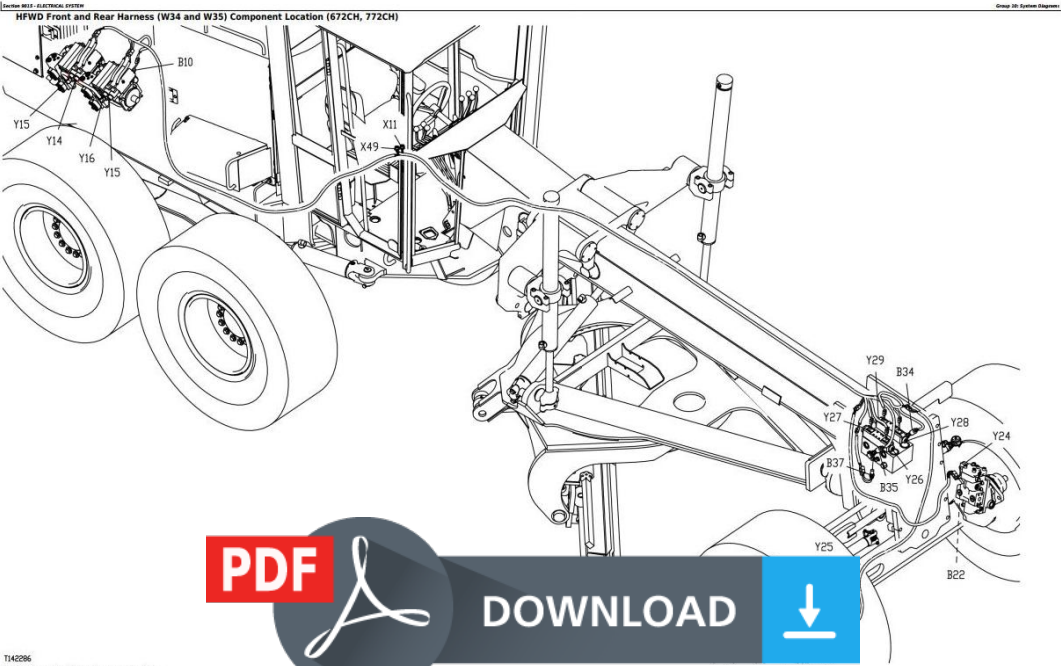

T142086
HFWD Front and Rear Harness Component Location

Covers: 6415,6615,7515

Type: Service Manual

Language: English

Pages: 1669

Format: PDF

Features: Bookmarked, searchable, printable

Compatibility: Windows/Mac/Tablet/Mobile

This service manual contains important information for the maintenance, troubleshooting and servicing of the **John Deere Tractors Models 6415, 6615, 7515 (South America) Diagnostic and Tests Service Manual (TM8128)**

In this manual you will find detailed specifications, illustrations, schematics, diagrams and step-by-step procedures to properly service and diagnose the machine to the manufacturer's standards.

Contents:

- General Information
- Specifications
- Serial Number Location
- Engine Specifications
- Engine Diagnostics
- Engine Tests and Adjustments
- Engine Repair
- Power Train
- Transmission
- Axles
- Differential
- PTO
- Hydraulic System
- Electrical System
- Electrical Tests and Diagnostics
- Wiring Diagram / Schematic
- Ignition and Charging
- Steering
- Brakes
- Wheels
- Operator's Platform
- Body Panels
- Disassembly and Assembly
- Diagnostics, Tests and Adjustments
- Troubleshooting
- and much more...

Please note this manual is in **downloadable PDF format only**. If you have any questions about this product or would like to request sample pages, please contact us and reference the product name or SKU.

Item	Measurement	Specification
Slow Idle	Position	4.5—5.0 K ohms
Fast Idle	Position	1.5—1.8 K ohms
ECU—Fast Idle	Voltage Input (Maximum)	3.0—4.2 volt

[3] - Move engine speed lever high to low and check potentiometer resistance change through travel.

[4] - Connect throttle potentiometer (G) and check slow and fast idle speeds.

[5] - Recalibrate display tachometer if required. Go to [Calibrate Tachometer](#). (See section 9015-25.)

[6] - Move engine speed control lever full travel from low to fast idle while noting diagnostic trouble codes on monitor display. If diagnostic trouble code F411 is present, readjust throttle potentiometer linkage. See [Throttle Potentiometer Test—670CH, 672CH, 770C, 770CH, 772CH](#). (See Group 9010-25.)

Primary Fuel Filter, Drain Valve—670C, 670CH, 672CH (S.N. —589368)

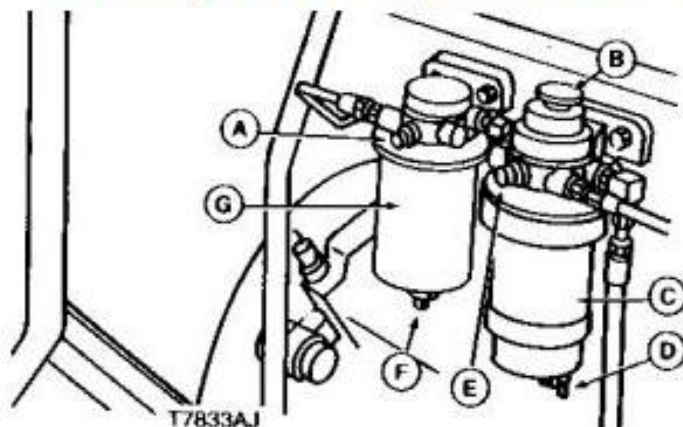

LEGEND:

- A Bleed Screw (Final Filter)
- B Pump
- C Primary Filter (Water Separator)
- D Drain Valve (Primary Filter)
- E Bleed Screw (Primary Filter)
- F Drain Valve (Final Filter)
- G Final Filter

Primary Filter Drain Valve

[1] - Place pan under primary filter (water separator) (C).

[2] - Open drain valve (D) on bottom of primary filter and press pump (B) to remove water from fuel system.

[3] - When water is removed close drain valve.

[4] - Open drain valve (F) on bottom of final filter (G) and press pump (B) to remove water.

[5] - When water is removed close drain valve.

Primary Fuel Filter, Drain Valve—670C, 670CH, 672CH (S.N. 589369—)

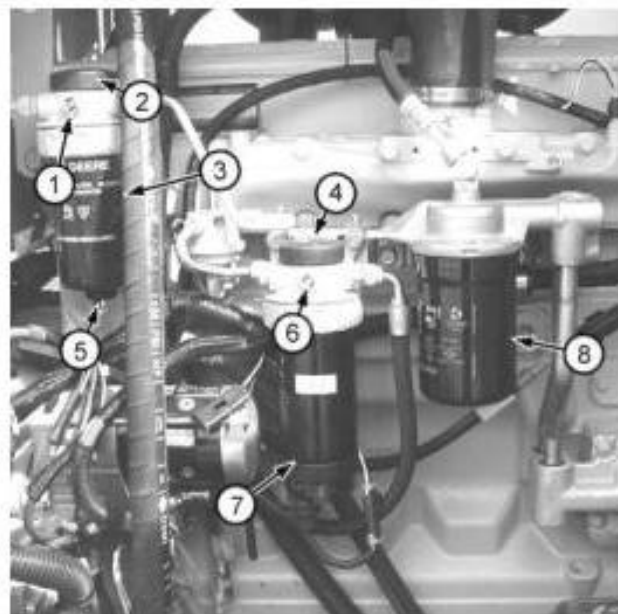

LEGEND:

- 1 Bleed Screw (Final Filter)
- 2 Pump (Final Filter)
- 3 Final Fuel Filter
- 4 Pump (Primary Filter)
- 5 Drain Valve (Primary Filter)
- 6 Bleed Screw (Primary Filter)
- 7 Primary Filter (Water Separator)
- 8 Engine Oil Filter



Thank you very much
for your reading.
Please click here
to get more information.