

POWERTECH® 4.5L & 6.8L Diesel Engines

Mechanical Fuel Systems

TECHNICAL MANUAL POWERTECH® 4.5 L & 6.8 L Diesel Engines — Mechanical Fuel Systems

CTM207 06OCT04 (ENGLISH)

For complete service information also see:

POWERTECH® 4.5 L and 6.8 L Diesel Engines—Base Engine	CTM104
Alternators and Starter Motors	CTM77
OEM Engine Accessories	CTM67 (English Only)
POWERTECH® 4.5 L and 6.8 L Diesel Engines—Level 4 Electronic with Bosch VP44 Pump	
POWERTECH® 4.5 L and 6.8 L Diesel Engines—Level 12 Electronic Fuel with Stanadyne DE10 Pump	CTM331
POWERTECH® 4.5 L and 6.8 L Diesel Engines—Level 1 Electronic Fuel Systems with Delphi/Lucas DP201 Pump	CTM284
POWERTECH® 4.5 L and 6.8 L Diesel Engines—Level 11 Electronic Fuel Systems with Denso High Pressure Common Rail. . .	CTM220



Introduction

Foreword

This manual is written for an experienced technician. Essential tools required in performing certain service work are identified in this manual and are recommended for use.

This manual (CTM207) covers only mechanical fuel systems. It is one of six volumes on 4.5 L and 6.8 L engines. The following five companion manuals cover the base engine plus electronic fuel system repair, operation and diagnostics:

- CTM104—Base Engine
- CTM170—Level 4 Electronic Fuel Systems with Bosch VP44 Pump
- CTM331—Level 12 Electronic Fuel Systems with Stanadyne DE10 Pump
- CTM284—Level 1 Electronic Fuel Systems with Delphi/Lucas DP201 Pump
- CTM220—Level 11 Electronic Fuel Systems with Denso High Pressure Common Rail

Other manuals will be added in the future to provide additional information on electronic fuel systems as needed.

Live with safety: Read the safety messages in the introduction of this manual and the cautions presented throughout the text of the manual.

 This is the safety-alert symbol. When you see this symbol on the machine or in this manual, be alert to the potential for personal injury.

Use this component technical manual in conjunction with the machine technical manual. An application listing in Section 01, Group 001 identifies product-model/component type-model relationship. See the machine technical manual for information on

component removal and installation, and gaining access to the components.

Information is organized in sections and groups for the various components requiring service instruction. Section 05 summarizes all applicable essential tools, service equipment and tools, other materials needed to do the job, and service parts kits. Section 06 summarizes all specifications, wear tolerances, and torque values.

Before beginning repair on an engine, clean the engine and mount on a repair stand.

This manual contains SI Metric units of measure followed immediately by the U.S. customary units of measure. Most hardware on these engines is metric sized.

Some components of this engine may be serviced without removing the engine from the machine. Refer to the specific machine technical manual for information on components that can be serviced without removing the engine from the machine and for engine removal and installation procedures.

Read each block of material completely before performing service to check for differences in procedures or specifications. Follow only the procedures that apply to the engine model number you are working on. If only one procedure is given, that procedure applies to all the engines in the manual.

CALIFORNIA PROPOSITION 65 WARNING
Diesel engine exhaust and some of its constituents are known to the State of California to cause cancer, birth defects and other reproductive harm.

OUO1032,00014BA -19-19AUG04-1/1

John Deere Dealers

Discard CTM207 dated 17SEP02 or 14MAY03 and replace with this new manual.

Also, copy this page **listing changes** to this new CTM207 and route through your Service Department.

SECTION 01—GROUP 001 (Engine Identification)

- Updated engine model designation chart.
- Updated engine application charts.

SECTION 01—GROUP 002 (Fuels)

- Revised diesel fuel specifications.
- Revised lubricity of diesel fuel specifications.
- Added bio-diesel fuel specifications.
- Added Dieselscan fuel analysis specifications.

SECTION 02—GROUP 090 (Mechanical Fuel System Repair and Adjustments)

- Added note regarding substitution of longer fuel filter elements and addition of sediment bowls when appropriate.
- Added remove and install procedure for Delphi/Lucas fuel shut-off solenoid.
- Added remove and install procedure for Delphi/Lucas cold start advance switch and harness.
- Revised inspection procedure for Stanadyne injection pump drive gear ID and shaft OD.
- Revised Stanadyne DB2 fuel injection pump drive gear-to-shaft retaining nut torque specification.
- Revised repair instruction for Motorpal fuel injection pumps.
- Revised bleeding procedure.

SECTION 03—GROUP 130 (Mechanical Fuel Systems Operation)

- Revised operational description of rotary fuel supply pumps.

SECTION 04—GROUP 150 (Mechanical Fuel Systems Observable Diagnostics and Tests)

- Added warning statements regarding air, water, and contaminants in fuel pump housings leading to premature pump failure.
- Revised specifications for supply pump pressure tests.
- Revised rotary pump cold start advance check to refer to new solenoid removal and installation story in Section 02.
- Added warning statement to fuel injection nozzle test regarding fluids under pressure.
- Revised bleeding procedure.

SECTION 05 (Tools and Other Materials)

- All essential tools, service tools, dealer fabricated tools and other materials listed throughout this manual are consolidated in this section for ease of reference.

SECTION 06 (Specifications)

- All repair, test and diagnostic specifications listed throughout this manual are consolidated in this section for ease of reference.

OUO1032,00014C2 -19-23AUG04-1/1

POWERTECH® 4.5L Engine with Mechanical Fuel System

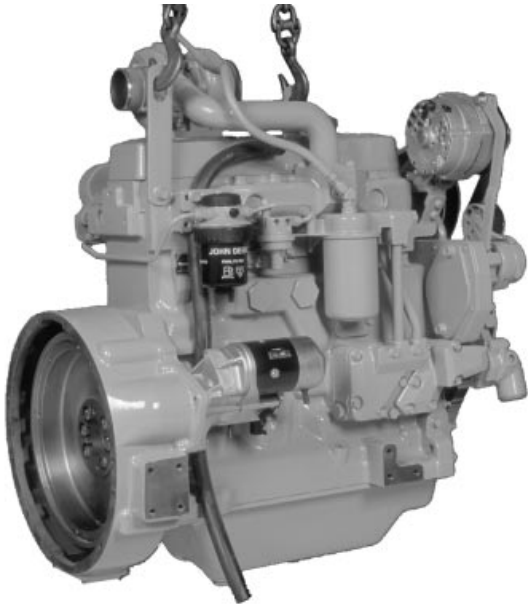

3/4 Right Rear View

RG7636 -UN-23NOV97



3/4 Left Rear View

RG7638 -UN-23NOV97

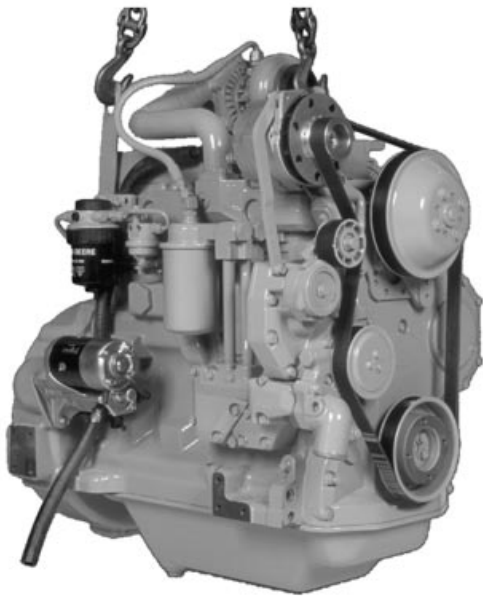

3/4 Right Front View

RG7639 -UN-23NOV97

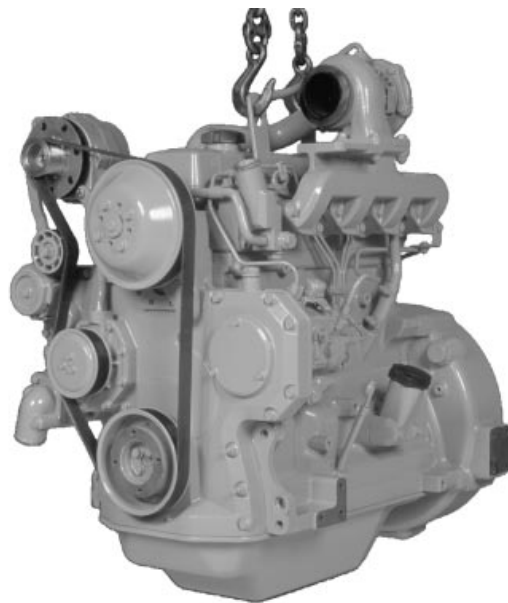

3/4 Left Front View

RG7637 -UN-23NOV97

POWERTECH is a registered trademark of Deere & Company

DPSG,OUO1004,129 -19-09SEP02-1/1

POWERTECH® 6.8L Engine with Mechanical Fuel System

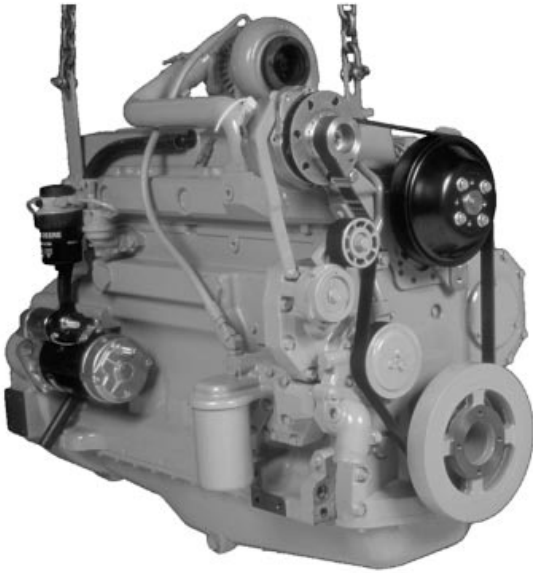

3/4 Right Front View

RG7641 -UN-23NOV97

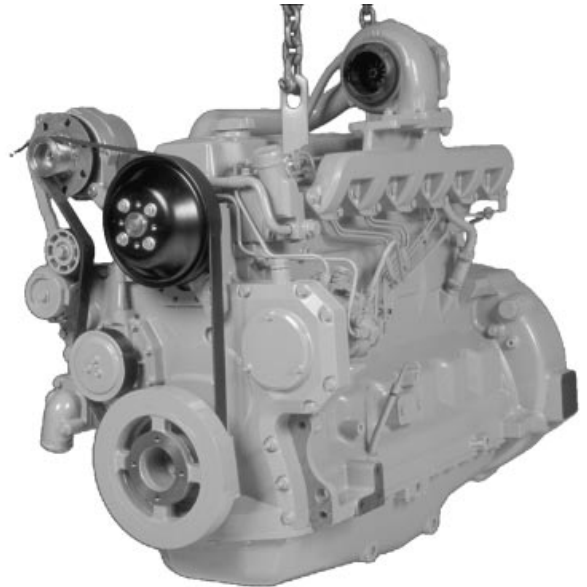

3/4 Left Front View

RG7640 -UN-23NOV97

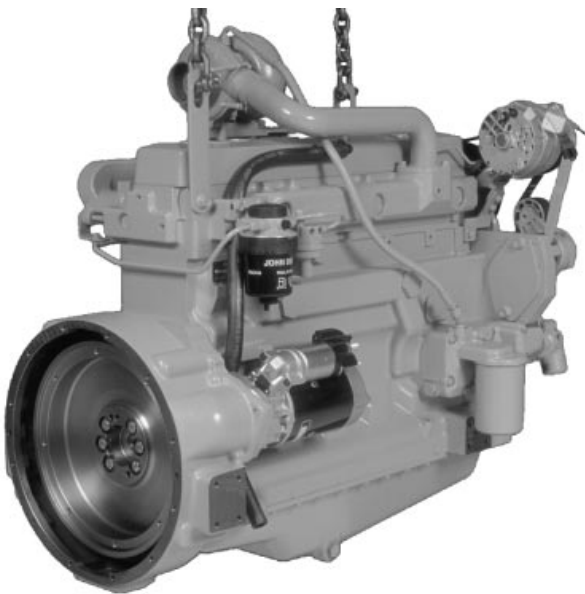

3/4 Right Rear View

RG7643 -UN-23NOV97

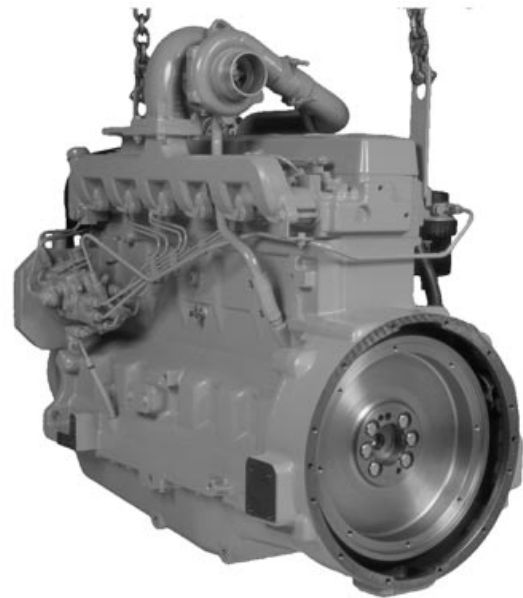

3/4 Left Rear View

RG7642 -UN-23NOV97

POWERTECH is a registered trademark of Deere & Company

DPSG.OU01004,130 -19-09SEP02-1/1



Thank you very much
for your reading.
Please click here
to get more information.