

TAKEUCHI

 ***TB250***

Serial No. 125000001~

Book No. BK7Z001

PDF



DOWNLOAD



PARTS MANUAL

SUZUKI

GSF1200/S

SERVICE MANUAL



FOREWORD

This manual contains an introductory description on SUZUKI GSF1200/S and procedures for its inspection/service and overhaul of its main components.

Other information considered as generally known is not included.

Read GENERAL INFORMATION section to familiarize yourself with outline of the vehicle and MAINTENANCE and other sections to use as a guide for proper inspection and service.

This manual will help you know the vehicle better so that you can assure your customers of your optimum and quick service.

* *This manual has been prepared on the basis of the latest specification at the time of publication.*

If modification has been made since then, difference may exist between the content of this manual and the actual vehicle.

* *Illustrations in this manual are used to show the basic principles of operation and work procedures.*

They may not represent the actual vehicle exactly in detail.

* *This manual is intended for those who have enough knowledge and skills for servicing SUZUKI vehicles. Without such knowledge and skills, you should not attempt servicing by relying on this manual only.*

Instead, please contact your nearby authorized SUZUKI motorcycle dealer.

SUZUKI MOTOR CORPORATION

Motorcycle Service Department

GROUP INDEX

GENERAL INFORMATION

1

PERIODIC MAINTENANCE

2

ENGINE

3

FUEL AND LUBRICATION SYSTEM

4

CHASSIS

5

ELECTRICAL SYSTEM

6

SERVICING INFORMATION

7

GSF1200V/SV ('97-MODEL)

8

GSF1200SAV ('97-MODEL)

9

**GSF1200W/SW ('98-MODEL)
GSF1200X/SX ('99-MODEL)**

10

**GSF1200SAW ('98-MODEL)
GSF1200SAX ('99-MODEL)**

11

SUZUKI GSF1200T/1200ST ('96-MODEL)



GSF1200T



GSF1200ST

*Difference between photographs and actual motorcycles depends on the markets.

SERIAL NUMBER LOCATION

The frame serial number or V.I.N. (Vehicle Identification Number) ① is stamped on the right side of the steering head pipe. The engine serial number ② is located on the right side of the crankcase. These numbers are required especially for registering the machine and ordering spare parts.

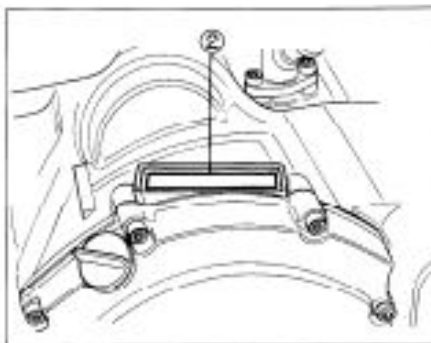
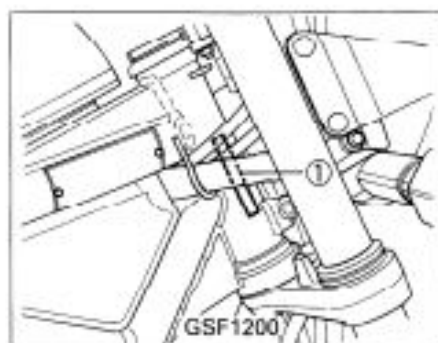

FUEL AND OIL RECOMMENDATION

FUEL (FOR CANADIAN MODEL)

Use only unleaded gasoline of at least 87 pump octane ($\frac{R+M}{2}$) method or 91 octane or higher rated by the research method.

FUEL (FOR THE OTHER MODELS)

Gasoline used should be graded 85–95 octane (Research Method) or higher. An unleaded gasoline type is recommended.

1996-1999 Suzuki GSF1200/S Motorcycle Service Repair Workshop Manual

Instant download 1996-1999 Suzuki GSF1200/S Motorcycle Service Repair Workshop Manual. This manual content all service, repair, maintenance, troubleshooting procedures for Suzuki Motorcycle Machine.

All major topics are covered step-by-step instruction, diagrams, illustration, wiring schematic, and specifications to repair and troubleshoot. With this factory service repair manual on hand can easily help you with any repairs that you may need for your Suzuki Motorcycle Machine.

Machine model :

GSF1200/S

Manual Covers:

*General Information

*Periodic Maintenance

*Engine

*Fuel And Lubrication System

*Chassis

*Electrical System

*Servicing Information

*GSF1200V/SV(97-Model)

*GSF1200SAV(97-Model)

*GSF1200W/SW(98-Model)

*GSF1200X/SX(99-Model)

*GSF1200SAW(98-Model)

*GSF1200SAX(99-Model)

AND MORE SPECIFICATION:

Pages:387

Format: PDF

Language: English

Compatible: Win/MacAll pages are printable, so run off what you need & take it with you into the garage or workshop.

Save money \$\$ by doing your own repairs! It make it easy for any skill level with these very easy to follow, step-by-step instructions!

Instant download means no shipping cost or waiting for a CD to arrive in the mail you will receive this manual today via instant download on completion of payment via our secure payment processor. We accept all major credit/debit cards/paypal.

Instant download! Thank you for visiting!



Thank you very much
for your reading.
Please click here
to get more information.