

Challenger®
RB453 / RB463 / RB563 / RB463A / RB563A
Round Baler

SERVICE MANUAL
79027370 A Rev.

CONTENTS

GENERAL INFORMATION	01
DRIVE	02
PICKUP	03
ELECTRICAL	04
BALE FORMING	05
BALE WRAPPING	06
CHASSIS	07
HYDRAULIC	08
GTA CONSOLE I	09
RESERVED	10

© AGCO Corporation, 2007 All rights reserved.
Part Number 79027370 A Rev. (English)

Printed in U.S.A.
September 2007

Challenger®
RB453 / RB463 / RB563 / RB463A / RB563A
Round Baler

SERVICE MANUAL
79027370 A Rev.

01 - General Information

Contents

GENERAL INFORMATION

Introduction	01-1
Page Numbers	01-1
Units of Measurement	01-1
Replacement Parts	01-1
Serial Number Plate Location	01-1
Baler Components	01-2
Automatic Balers	01-2
Standard Balers	01-3
Baler Operation	01-4

SAFETY

Safety Alert Symbol	01-7
Safety Messages	01-7
Informational Messages	01-7
Safety Signs	01-8
A Word To The Operator	01-8
Operator Manual	01-9
Prepare For Operation	01-9
Operation	01-9
Travel On Public Roads	01-11
Fire Prevention	01-12
Maintenance	01-12
Tire Safety	01-14

SAFETY SIGNS

Safety Alert Symbol	01-15
Safety Messages	01-15
Informational Messages	01-15
Safety Signs	01-16
Safety Sign Location	01-17

Contents

SPECIFICATIONS

4 X 5 Baler	01-21
Dimensions and Weights (Without Mesh Wrap)	01-21
Bale Size	01-21
Bale Chamber	01-21
Lighting	01-22
Electronic Controls	01-22
Tires	01-22
Drives	01-22
Pickup	01-23
Bale Wrapping Mechanism	01-23
Tractor Requirements	01-23
Lubrication Specifications	01-23
Mesh Wrap	01-24
4 X 6 Baler	01-25
Dimensions and Weights (Without Mesh Wrap)	01-25
Bale Size	01-25
Bale Chamber	01-25
Lighting	01-26
Electronic Controls	01-26
Tires	01-26
Drives	01-26
Pickup	01-27
Bale Wrapping Mechanism	01-27
Tractor Requirements	01-27
Lubrication Specifications	01-27
Mesh Wrap	01-28
5 X 6 Baler	01-29
Dimensions and Weights (Without Mesh Wrap)	01-29
Bale Size	01-29
Bale Chamber	01-29
Lighting	01-30
Electronic Controls	01-30
Tires	01-30
Drives	01-30
Pickup	01-31
Bale Wrapping Mechanism	01-31
Tractor Requirements	01-31
Lubrication Specifications	01-31
Mesh Wrap	01-32
4 X 6 Automatic Baler	01-33
Dimensions and Weights (Without Mesh Wrap)	01-33
Bale Size	01-33
Bale Chamber	01-33
Lighting	01-34
Electronic Controls	01-34
Tires	01-34
Drives	01-34
Pickup	01-35
Bale Wrapping Mechanism	01-35
Tractor Requirements	01-35
Lubrication Specifications	01-35
Mesh Wrap	01-36

Contents

5 X 6 Automatic Baler	01-37
Dimensions and Weights (Without Mesh Wrap)	01-37
Bale Size	01-37
Bale Chamber	01-37
Lighting	01-38
Electronic Controls	01-38
Tires	01-38
Drives	01-38
Pickup	01-39
Bale Wrapping Mechanism	01-39
Tractor Requirements	01-39
Lubrication Specifications	01-39
Mesh Wrap	01-40
LUBRICATION	
Service Chart	01-41
Roller Chains	01-42
Standard Roller Chain	01-42
O-Ring Roller Chain	01-42
Gearbox	01-43
Grease Fittings	01-44
Mesh Wrap System	01-48
Sealed Bearings	01-48
Wheel Bearings	01-48
Hydraulic System (Automatic Balers Only)	01-49
GENERAL SERVICE PROCEDURES	
Bolt Torque Values	01-51
Working Under the Tailgate	01-51
Working Around The Mesh Wrap Attachment	01-51
Bearing Replacement (Eccentric Self-Locking Collar)	01-52
Gib Key Removal and Installation	01-53
INDEX	01-55

GENERAL INFORMATION

INTRODUCTION

This service manual has been prepared with the latest service information available at the time of publication. Read the service manual carefully before doing any service on the machine.

Right-hand and left-hand, as used in this manual, is determined by facing the direction the machine will travel when in use.

The photos, illustrations, and data used in this manual were current at the time of printing, but due to possible production changes, your machine can vary slightly. The Manufacturer reserves the right to redesign and change the machine as necessary without notification.

PAGE NUMBERS

All page numbers are made of two numbers separated by a dash, such as 04-9. The number before the dash is the division number. The number following the dash is the page number in that division. The page number will be at the lower right-hand or lower left-hand corner of each page.

UNITS OF MEASUREMENT

Measurements are given in metric units of measurement followed by the equivalent in U.S. units. Hardware sizes are given in millimeters for metric hardware and inches for U.S. hardware.

REPLACEMENT PARTS

To receive prompt efficient service, always remember to give the dealer the following information:

- Correct part description or part number.
- Model number of your machine.
- Serial number of your machine.

SERIAL NUMBER PLATE LOCATION

FIG. 1: The serial number plate (1) is located on the left-hand side of the side panel.

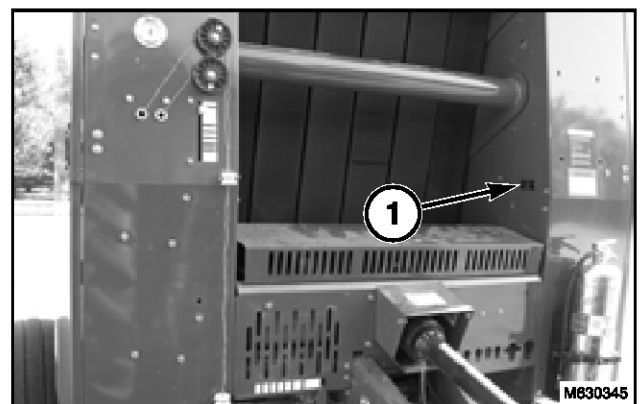

FIG. 1

General Information

BALER COMPONENTS

Automatic Balers

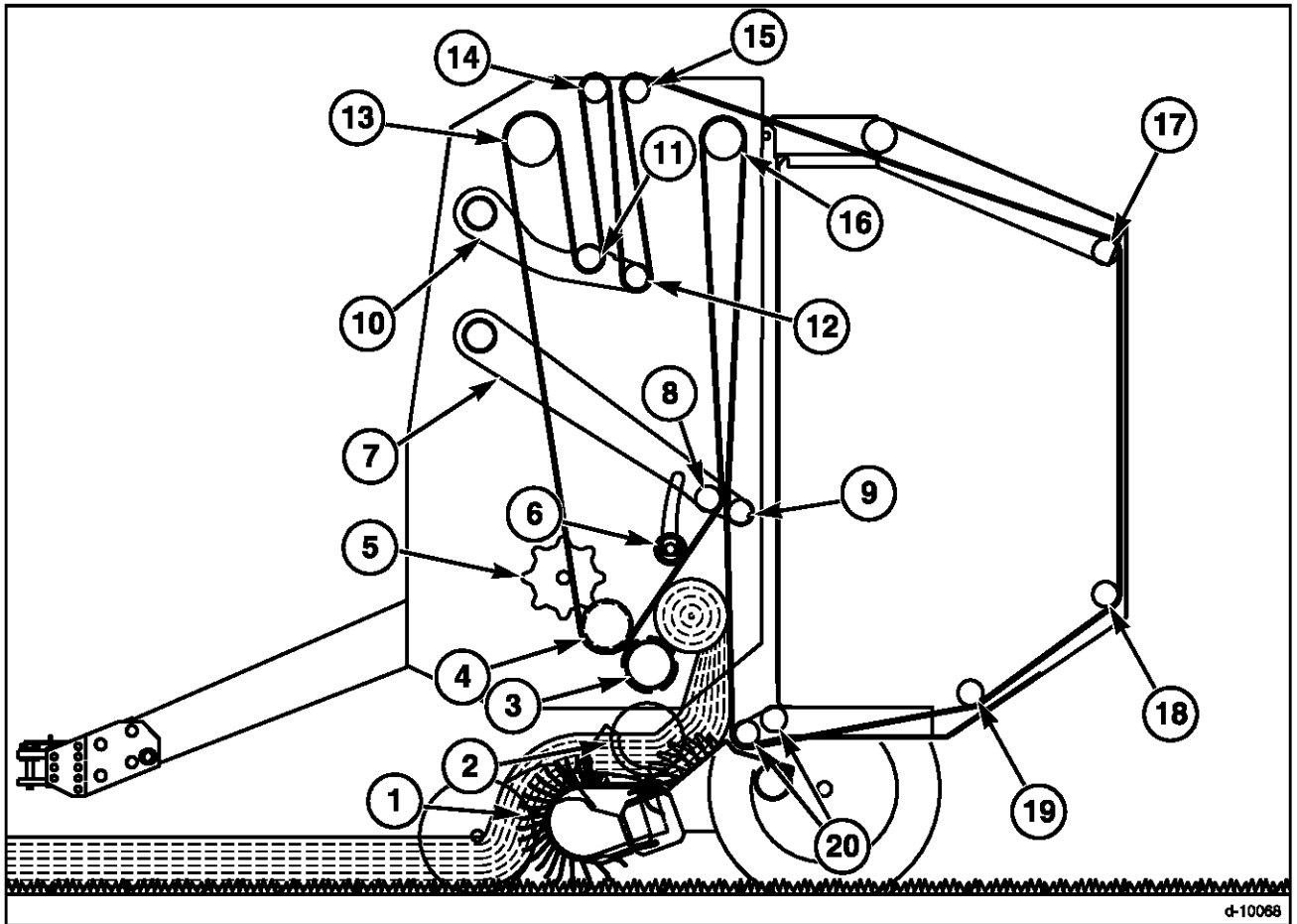
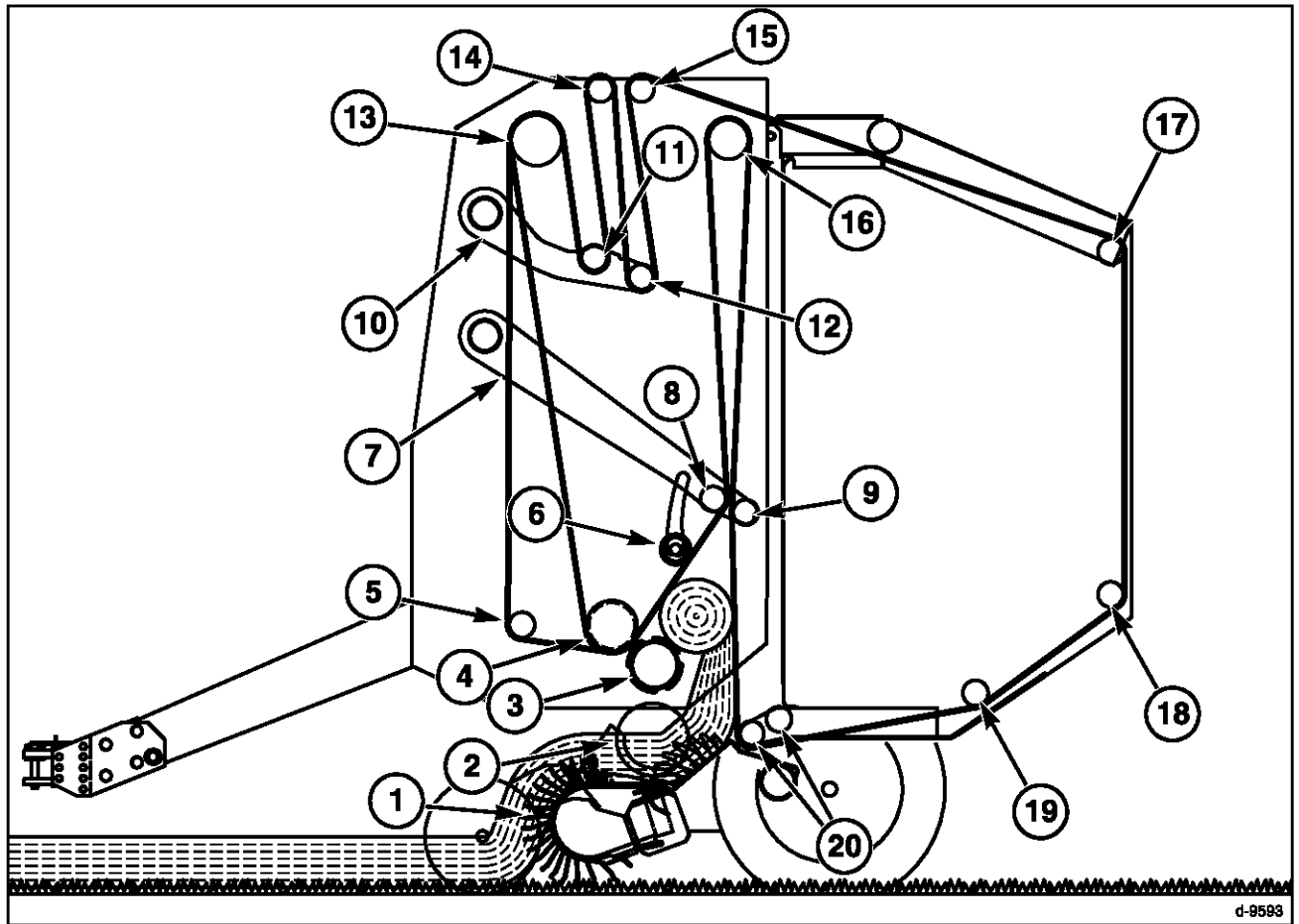

FIG. 2

FIG. 2: Baler Components

- | | |
|-------------------------------|--------------------------------|
| (1) Pickup Assembly | (11) Front Belt Tension Roll |
| (2) Augers | (12) Rear Belt Tension Roll |
| (3) Starting Roll | (13) Upper Drive Roll |
| (4) Lower Drive Roll | (14) Front Upper Idler Roll |
| (5) Rlenk Shaft | (15) Rear Upper Idler Roll |
| (6) Bale Shape Assembly Wheel | (16) Upper Chamber Roll |
| (7) Bale Density Arm | (17) Upper Rear Tailgate Roll |
| (8) Front Bale Density Roll | (18) Lower Rear Tailgate Roll |
| (9) Rear Bale Density Roll | (19) Lower Tailgate Idler Roll |
| (10) Belt Tension Arm | (20) Lower Front Idler Rolls |

Standard Balers



d-9593

FIG. 3

FIG. 3: Baler Components

- | | |
|-------------------------------|---|
| (1) Pickup Assembly | (11) Front Belt Tension Roll |
| (2) Augers | (12) Rear Belt Tension Roll |
| (3) Starting Roll | (13) Upper Drive Roll |
| (4) Lower Drive Roll | (14) Front Upper Idler Roll |
| (5) Stagger Roll | (15) Rear Upper Idler Roll |
| (6) Bale Shape Assembly Wheel | (16) Upper Chamber Roll |
| (7) Bale Density Arm | (17) Upper Rear Tailgate Roll |
| (8) Front Bale Density Roll | (18) Lower Rear Tailgate Roll |
| (9) Rear Bale Density Roll | (19) Lower Tailgate Idler Roll (6 foot diameter baler only) |
| (10) Belt Tension Arm | (20) Lower Front Idler Rolls |

General Information

BALER OPERATION

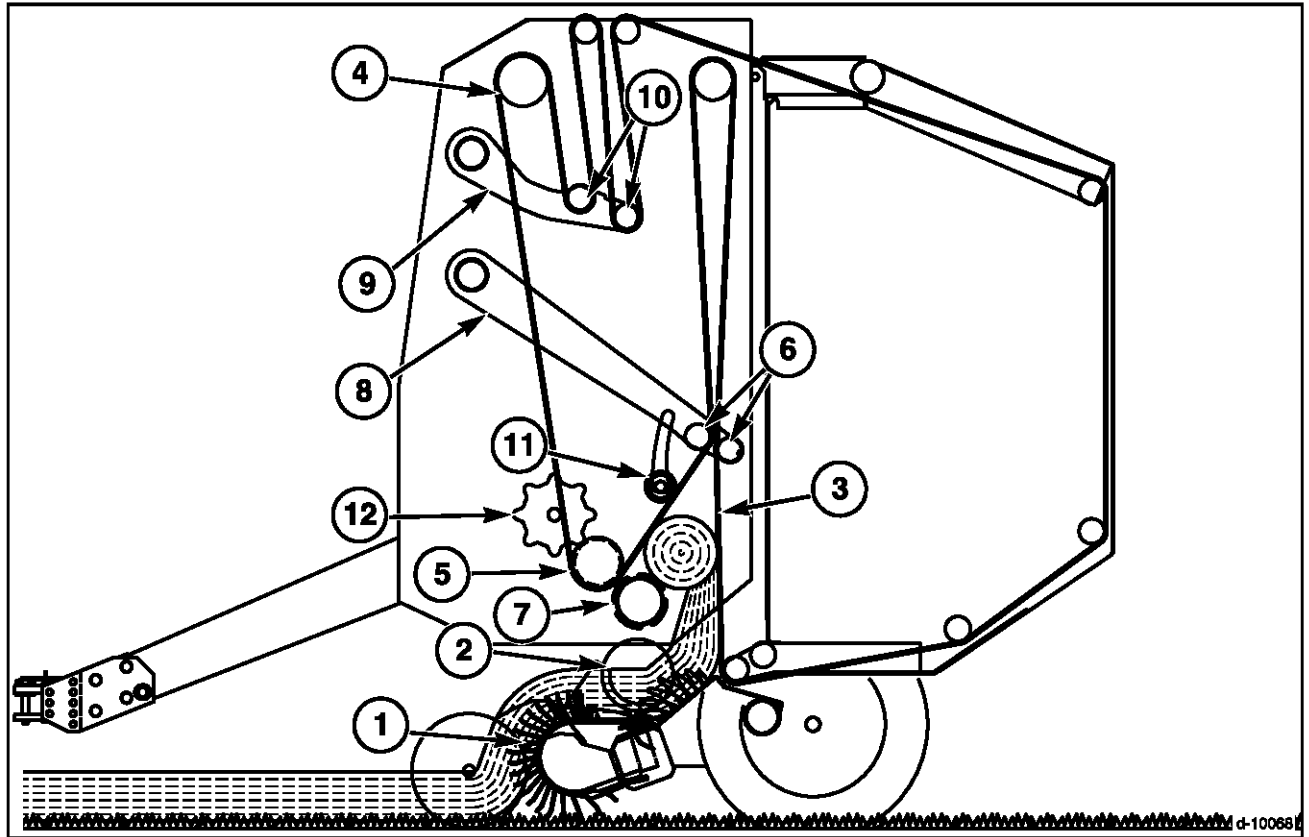

FIG. 4

FIG. 4: Windrowed crop is feed into the baler by the pickup assembly (1). The crop is moved to the chamber opening by the left-hand and right-hand augers (2). The stuffer assembly feeds the crop into the bottom of the open throat bale chamber. In the bale chamber the crop contacts the rough top surface of the forming belts (3), which are moving upward. The forming belts are driven by the upper (4) and lower (5) drive rolls. The forming belts carry the crop to the top of the starting chamber that is formed by the front and rear bale density rolls (6). The motion of the forming belts turns the crop downward against the starting roll (7). The core is started and begins to roll.

Hydraulic cylinders pull down on the bale density (8) and belt tension (9) arms for the bale density rolls and belt tension rolls (10). The bale density rolls are held down to reduce the size of the bale chamber to a starting size. The belt tension rolls are held down to supply tension to the forming belts. As the bale increases in size, the bale density rolls and the belt tension rolls are forced up. The bale density rolls put an increasing amount of force down against the bale. This force keeps tension on the bale and compresses the crop coming into the bale chamber. The belt tension rolls move upward to give more forming belt for the increased size of the bale chamber.

The bale shape assembly wheels (11) control the bale shape indicator on the console. The bale shape indicator directs the operator to correctly fill the bale chamber.

On automatic balers, the rients (12) are located between the forming belts and clean loose crop from between the forming belts during baling.

On standard balers, the belts are staggered to clean loose crop from between the forming belts during baling.

General Information

FIG. 5: The illustration shows a bale that is almost finished. The belt tension rolls have moved up to increase the size of the bale chamber.

The bale is being supported by the starting roll, lower drive roll, lower front idler roll, lower tailgate idler roll, and the forming belts. The bale is ready to be wrapped and unloaded.

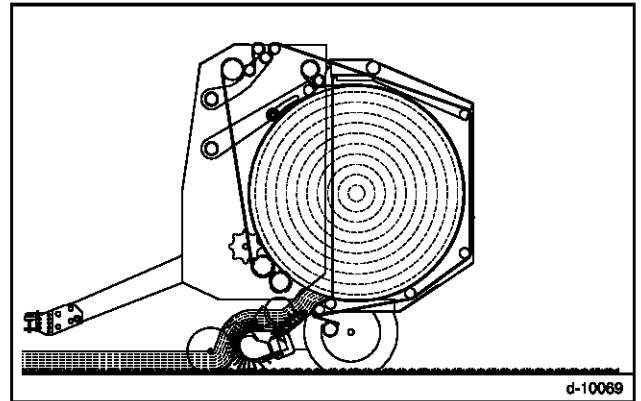

FIG. 5

FIG. 6: When the bale has been unloaded, the kicker is sent out to push the bale away from the tailgate. The tailgate is then lowered and the kicker sent home. The main drive clutch is engaged and the forming belts begin running. When the drive forward symbol is illuminated, the next bale can be made.

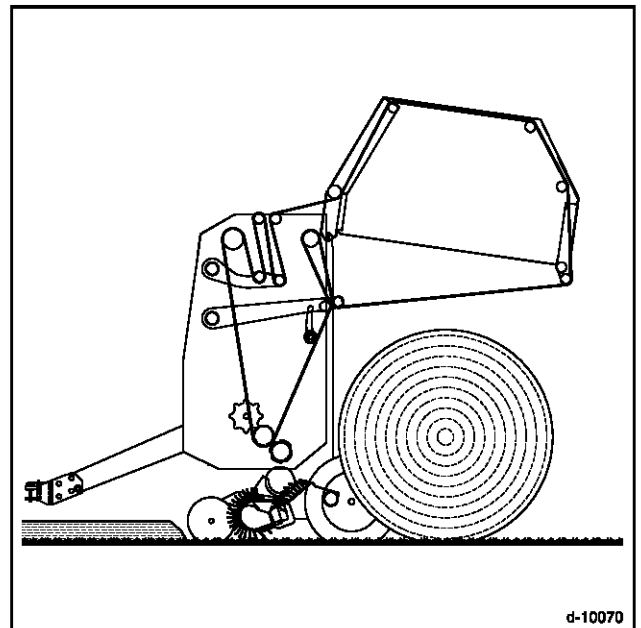

FIG. 6

NOTES

SAFETY

SAFETY ALERT SYMBOL

FIG. 7: The safety alert symbol means ATTENTION! BECOME ALERT! YOUR SAFETY IS INVOLVED!

Look for the safety alert symbol both in this manual and on safety signs on this machine. The safety alert symbol will direct your attention to information that involves your safety and the safety of others.



FIG. 7

SAFETY MESSAGES

FIG. 8: The words DANGER, WARNING or CAUTION are used with the safety alert symbol. Learn to recognize these safety alerts and follow the recommended precautions and safety practices.

 **DANGER:** Indicates an imminently hazardous situation that, if not avoided, will result in DEATH OR VERY SERIOUS INJURY.

 **WARNING:** Indicates a potentially hazardous situation that, if not avoided, could result in DEATH OR SERIOUS INJURY.

 **CAUTION:** Indicates a potentially hazardous situation that, if not avoided, may result in MINOR INJURY.



FIG. 8

INFORMATIONAL MESSAGES

The words IMPORTANT and NOTE are not related to personal safety, but are used to give additional information and tips for operating or servicing this equipment.

IMPORTANT: Identifies special instructions or procedures which, if not strictly observed, could result in damage to or destruction of the machine, process, or its surroundings.

NOTE: Identifies points of particular interest for more efficient and convenient repair or operation.

Safety

SAFETY SIGNS



WARNING: DO NOT remove or obscure Danger, Warning or Caution signs. Replace any Danger, Warning or Caution signs that are not readable or are missing. Replacement signs are available from your dealer in the event of loss or damage. The actual location of the safety signs is illustrated at the end of this section.

If a used machine has been purchased, make sure all safety signs are in the correct location and can be read.

See Safety Sign Location of this section for illustrations.

Replace any safety signs that can not be read or are missing. Replacement safety signs are available from your dealer.

A WORD TO THE OPERATOR

FIG. 9: It is YOUR responsibility to read and understand the safety section in this book before operating this machine. Remember that YOU are the key to safety. Good safety practices not only protect you, but also the people around you. Study the features in this book and make them a working part of your safety program. Keep in mind that this safety section is written only for this type of machine. Practice all other usual and customary safe working precautions, and above all **REMEMBER - SAFETY IS YOUR RESPONSIBILITY. YOU CAN PREVENT SERIOUS INJURY OR DEATH.**

This safety section is intended to point out some of the basic safety situations that may be encountered during the normal operation and maintenance of your machine, and to suggest possible ways of dealing with these situations. This section is NOT a replacement for other safety practices featured in other sections of this book.

IMPORTANT: *This manual covers general safety practices for this machine. It must always be kept with the machine. After using this manual, return it to the container on the machine.*



WARNING: An operator should not use alcohol or drugs which can affect their alertness or coordination. An operator on prescription or 'over the counter' drugs needs medical advice on whether or not they can properly operate machines.

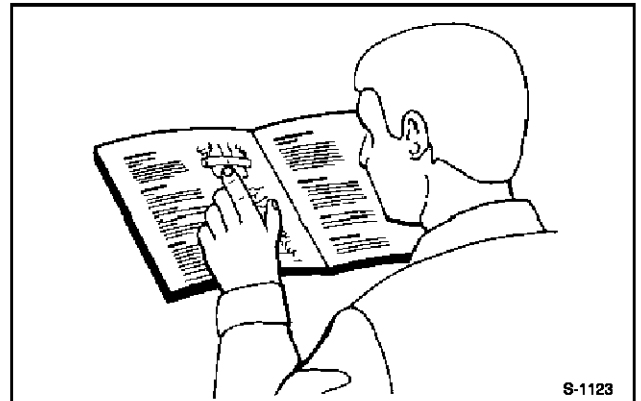

FIG. 9

OPERATOR MANUAL

FIG. 10: The Operator Manual is kept in the Operator Manual container (1) on the baler. After using the Operator Manual, return the manual to the storage container.

The photos, illustrations, and data used in this manual were current at the time of printing, but due to possible in-line production changes, your machine can vary slightly in detail. The manufacturer reserves the right to redesign and change the machine as necessary without notification.



WARNING: In some of the illustrations or photos used in this manual, panels or guards may have been removed for clarity. Never operate the machine with any panels or guards removed. If the removal of panels or guards is necessary to make a repair, they **MUST** be replaced before operation.

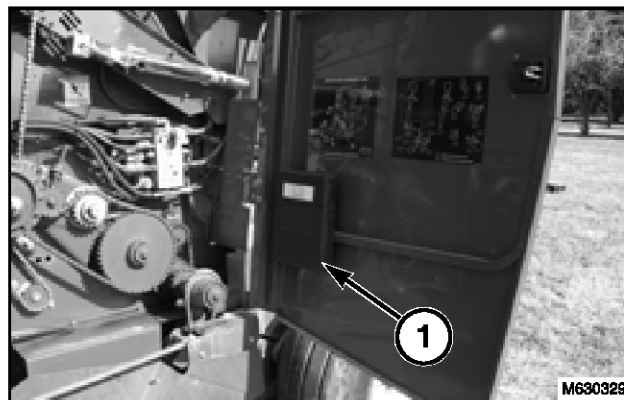

FIG. 10

PREPARE FOR OPERATION

Read this manual completely and make sure you understand the controls. Know the positions and operations of all controls before you operate this machine. Check all controls in an area clear of people and obstacles before starting your work.

All equipment has a limit. Make sure you understand the speed, brakes, steering, stability, and load characteristics of this machine before you start.

Make sure your machine has the correct equipment needed by the local regulations.

OPERATION

Make sure the machine is in the proper operating condition as stated in the Operator Manual.

Make sure the tractor is in proper operating condition with the brakes adjusted, especially when operating on terrain that is not even.

To achieve proper braking capacity, the weight of the baler with a bale must not exceed 1.5 times the weight of the tractor.

FIG. 11: Wear all protective clothing and personal protective equipment issued to you or called for by job conditions. Wear approved hearing protection whenever operating the machine as required by country/local regulations. **DO NOT** wear loose clothing, jewelry, or other items that could entangle in moving parts. Tie up long hair that also could entangle in moving parts. Always keep hands, feet, hair, and clothing away from moving parts.

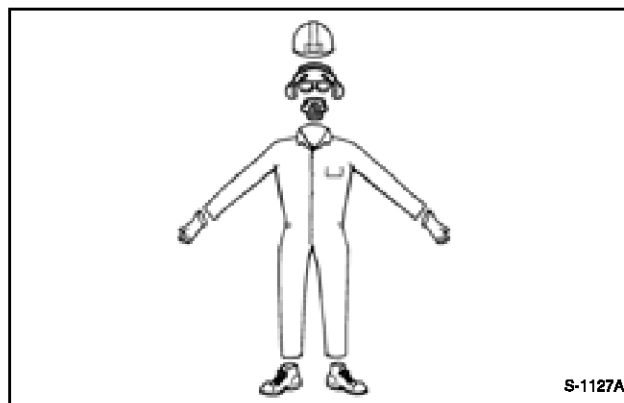

FIG. 11

Safety

FIG. 12: Securely fasten your seat belt before operating the machine. Always remain seated when operating the machine.

Always operate the baler with the control console turned on.

Never start the tractor with PTO engaged or control console turned on.

Always slide the hitch pin lock plate over the hitch pin and install the Klik pin when connecting the baler to the tractor.

Always install the safety transport chain between the baler and tractor drawbar.

- Use a chain with a strength rating equal to or more than the gross weight of the towed machine.
- Supply only enough slack in the chain to permit turning.
- Do not use the safety transport chain as a tow chain for towing.

FIG. 13: Always put the tractor transmission in park and apply the parking brake and remove the tractor key when parking the machine and take the key with you.

DO NOT allow children or unqualified persons to operate your machine.

DO NOT permit others to ride on the machine. Keep others away from your area of work.

FIG. 14: Because of the flammable nature of many hay crops, a water fire extinguisher must be placed within easy reach.

Keep a first aid kit handy for treatment for minor cuts and scratches.

Keep fingers clear of the feed roll pinch point when threading the mesh wrap.

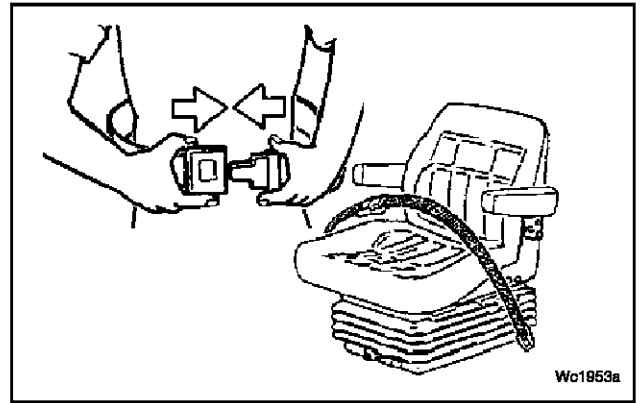

FIG. 12

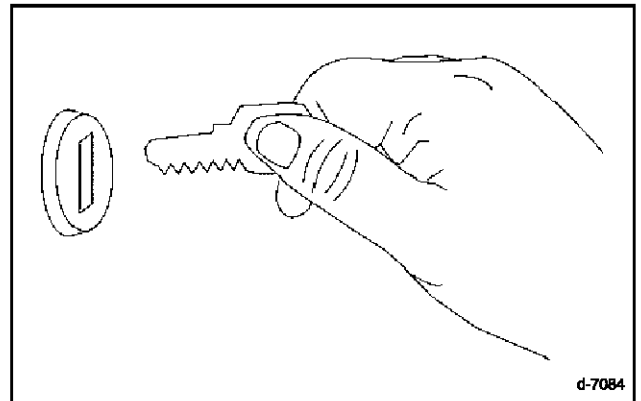

FIG. 13

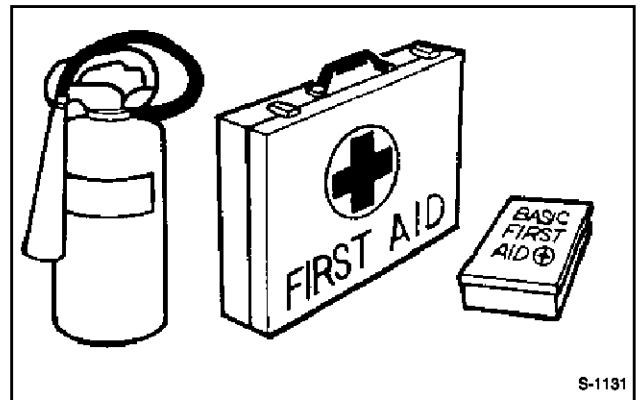

FIG. 14

FIG. 15: Stay at least 3.7 m (12 ft) away from the tailgate and kicker at all times. The tailgate and kicker operate faster than you can move away.

Always make sure the area around the tailgate and the kicker is clear for at least 3.7 m (12 ft) before opening the tailgate and unloading the bale. Keep bystanders away from the baler and the tailgate when unloading a bale.

Before raising the tailgate, make sure the baler is securely fastened to the tractor drawbar. The baler tongue may lift up when the tailgate is raised. This can cause the baler to tip to the rear, causing personal injury or damage to the machine.

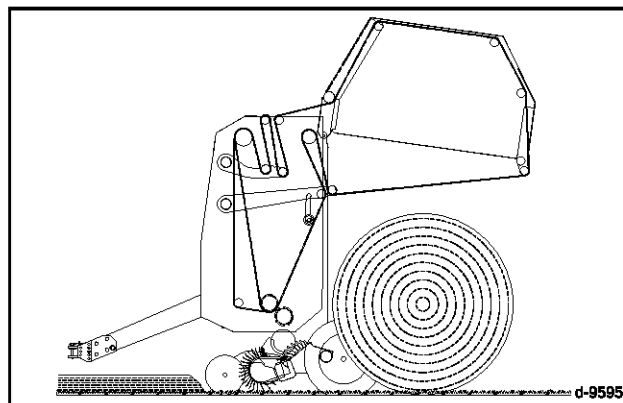

FIG. 15

FIG. 16: When moving bales, never use a tractor front end loader that is not equipped with a grapple or the proper bale handling equipment. Use the grapple to prevent the bale from rolling down the loader frame onto the operator. Always keep the load close to the ground to keep from off-balancing the tractor.

Never unload or store bales on a slope where bales can roll.

Always disengage the tractor PTO, put the tractor transmission in PARK and apply the parking brake before getting off of the tractor. Stop the tractor engine and remove the key before servicing or doing any maintenance on the machine.

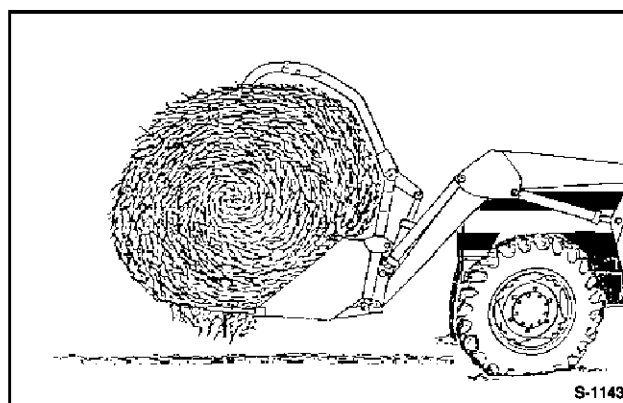

FIG. 16

TRAVEL ON PUBLIC ROADS

FIG. 17: Use the lighting and marking system supplied with the machine when roading.

Make sure reflectors are correctly installed, in good condition, and wiped clean. Be sure the SMV emblem is clean, visible, and correctly mounted on the rear of the machine.

Familiarize yourself with and obey all road regulations that apply to your machine. Consult your local law enforcement agency for local regulations regarding movement of farm equipment on public roads.

Adjust travel speed to maintain control at all times. Limit speeds to 32 km/hr (20 mi/hr).

Be aware of other traffic on the road. Keep well over to your own side of the road and pull over, whenever possible, to let faster traffic pass.

Be aware of the overall width and length of the machine. Be careful when transporting the machine on narrow roads and across narrow bridges.

Do not operate this baler on the road with a bale in the chamber.

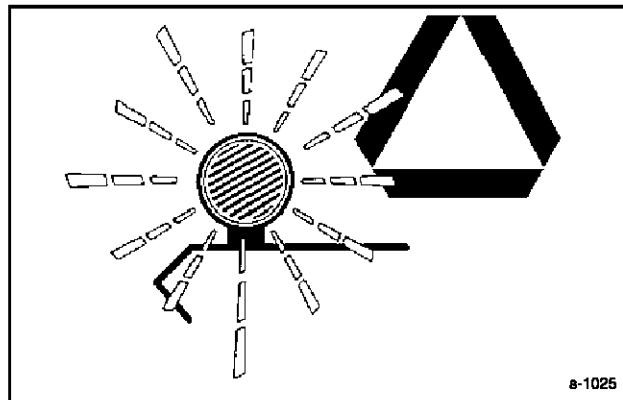

FIG. 17

Safety

FIRE PREVENTION

FIG. 18: Due to the nature of the crops this machine will operate in, the risk of fire is of concern. Regular inspection of the machine can reduce the risk of fire. Keep the machine free of crop debris.

Check the machine daily for any noises that are not normal. Such noises could indicate a failed bearing that can cause heat buildup.

When finished baling and before leaving baler, remove the bale from the bale chamber. Raise the tailgate and put the tailgate lockout valve in the lock position. Check for accumulation of hay or hot spots in the bale chamber and pickup area. Remove hay accumulation. Put the tailgate lockout valve in the unlock position and lower the tailgate.

If a fire occurs while baling, eject the bale, move tractor and baler upwind away from bale 12 m (40 ft). Raise the tailgate. Engage the tailgate lockout valve in the LOCKED position. Use a fire extinguisher or other water source to put out the fire.

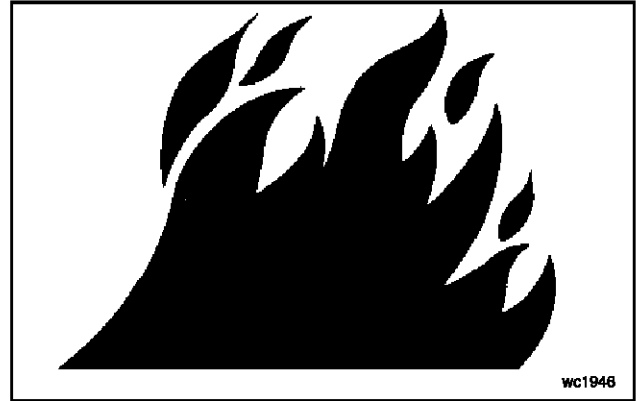

FIG. 18

MAINTENANCE

FIG. 19: Before doing any unplugging, lubricating, servicing, cleaning, or adjusting:

- Park the machine on a solid level surface.
- Close the tailgate.
- Disengage the tractor PTO.
- Put the tractor transmission in PARK and apply the tractor parking brake.
- Turn off the control console.
- Stop the tractor engine and take the key with you.
- Put the tailgate lockout valve into the LOCKED position.
- Look and Listen! Make sure all moving parts have stopped.
- Put blocks in front of and behind the wheels of the tractor and the baler before working on or under the baler.

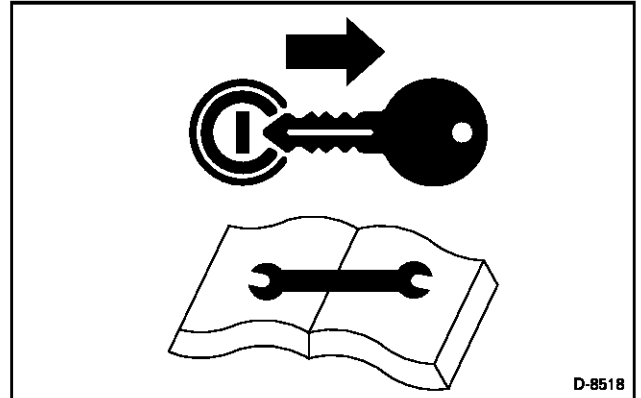

FIG. 19

FIG. 20: Never service, check or adjust drive chains or belts while the tractor engine is running.

Never remove crop, twine, or mesh wrap from the machine while the tractor engine is running. Moving parts can pull you in faster than you can move away.

Check all nuts and bolts periodically for tightness.

After unplugging, lubricating, servicing, cleaning, or adjusting the machine make sure all tools and equipment have been removed.

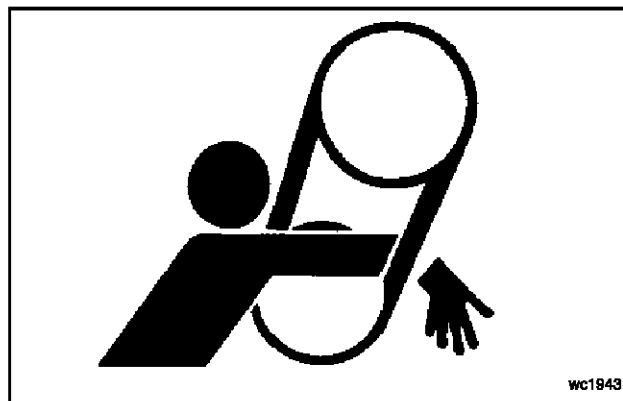

FIG. 20

FIG. 21: DO NOT operate the machine with drive shafts shields open or removed. Entanglement in rotating drive shafts can cause serious injury or death.

Stay clear of rotating components.

Make sure rotating guards turn freely.

A loose yoke can slip off the tractor PTO shaft and result in injury to persons or damage to the machine.

When installing a quick disconnect yoke, the spring activated locking pins must slide freely and be seated in the groove on the PTO shaft.

Pull on the implement driveline to make sure the quick disconnect yoke cannot be pulled off the PTO shaft.



FIG. 21

FIG. 22: When the tailgate is raised for any maintenance or service work, put the tailgate lockout valve (1) into the LOCKED position.

The tailgate can only be lowered when the tailgate lockout valve is released (pulled out).

Always unload the bale from the bale chamber before raising or working under the machine.

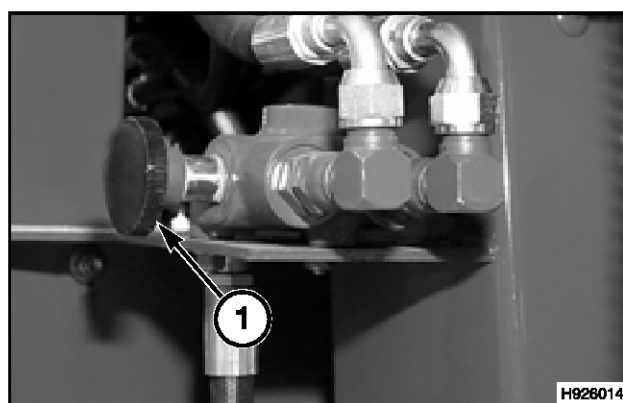

FIG. 22

FIG. 23: The mesh wrap cut off arm can move rapidly without warning. Engage the cut off arm lock (1) to lock the mesh wrap cutoff arm in the up position before servicing or loading mesh wrap.

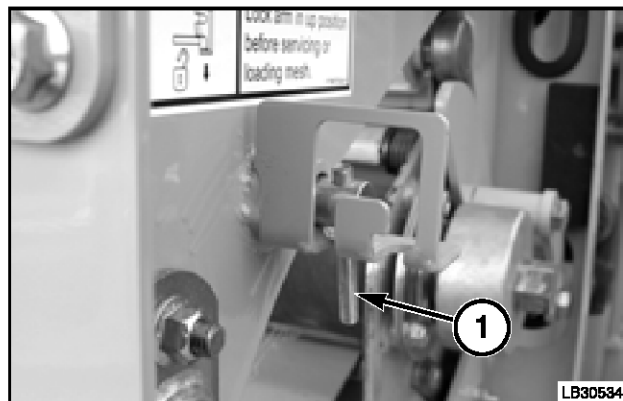
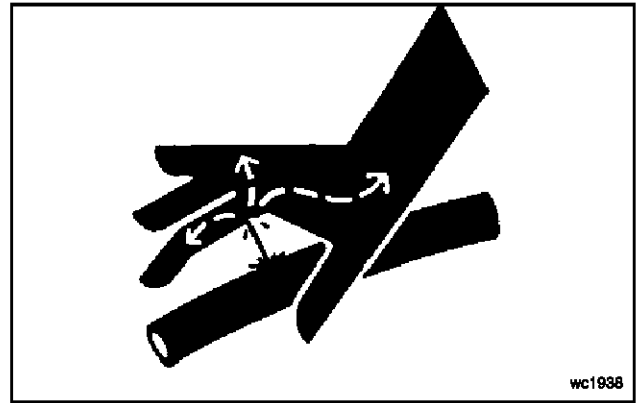

FIG. 23

Safety

FIG. 24: Escaping hydraulic fluid under high pressure can be almost invisible but can penetrate the skin causing serious injury.

Fluid injected into the skin must be surgically removed within a few hours. If not treated immediately, serious infection or reaction can develop. See a doctor familiar with this type of injury immediately.



wc1938

FIG. 24

FIG. 25: Use a piece of cardboard or wood to search for possible leaks, never use your hands. Wear leather gloves for hand protection and safety goggles for eye protection. DO NOT use your bare hand.

Relieve all pressure before disconnecting any hydraulic lines. Make sure all connections are tight and hydraulic lines are not damaged before applying pressure.

Make sure electrical connectors are free of dirt and grease before connecting.

Check for loose, broken, missing, or damaged parts. Have everything in good repair. Make sure all guards and shields are in place.

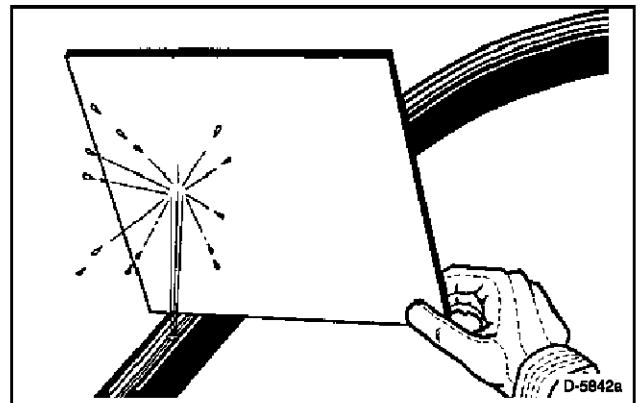

D-5842a

FIG. 25

TIRE SAFETY

FIG. 26: Tire explosion and/or serious injury can result from over inflation. Do not exceed tire inflation pressures. See Tires in the Specifications section for correct tire pressure.

Check tires for cuts and bulges. Replace worn or damaged tires. When tire service is necessary, have a qualified tire mechanic service the tire. See Tires in the Specifications section for correct tire size.

Do not weld on the rim when a tire is installed. Welding will cause an explosive air/gas mixture that will ignite with high temperatures. This can happen to tires that are inflated or deflated. Removing air or breaking the bead is NOT enough.



D-8386

FIG. 26

SAFETY SIGNS

SAFETY ALERT SYMBOL

FIG. 27: The safety alert symbol means ATTENTION! BECOME ALERT! YOUR SAFETY IS INVOLVED!

Look for the safety alert symbol both in this manual and on safety signs on this machine. The safety alert symbol will direct your attention to information that involves your safety and the safety of others.



FIG. 27

SAFETY MESSAGES

FIG. 28: The words DANGER, WARNING or CAUTION are used with the safety alert symbol. Learn to recognize these safety alerts and follow the recommended precautions and safety practices.

 **DANGER:** Indicates an imminently hazardous situation that, if not avoided, will result in DEATH OR VERY SERIOUS INJURY.

 **WARNING:** Indicates a potentially hazardous situation that, if not avoided, could result in DEATH OR SERIOUS INJURY.

 **CAUTION:** Indicates a potentially hazardous situation that, if not avoided, may result in MINOR INJURY.



FIG. 28

INFORMATIONAL MESSAGES

The words IMPORTANT and NOTE are not related to personal safety, but are used to give additional information and tips for operating or servicing this equipment.

IMPORTANT: Identifies special instructions or procedures which, if not strictly observed, could result in damage to or destruction of the machine, process, or its surroundings.

NOTE: Identifies points of particular interest for more efficient and convenient repair or operation.

