

JCB VMS 71 , 71-20 , 71-30 Single Drum Roller Service Repair Manual (VMS71 Series)

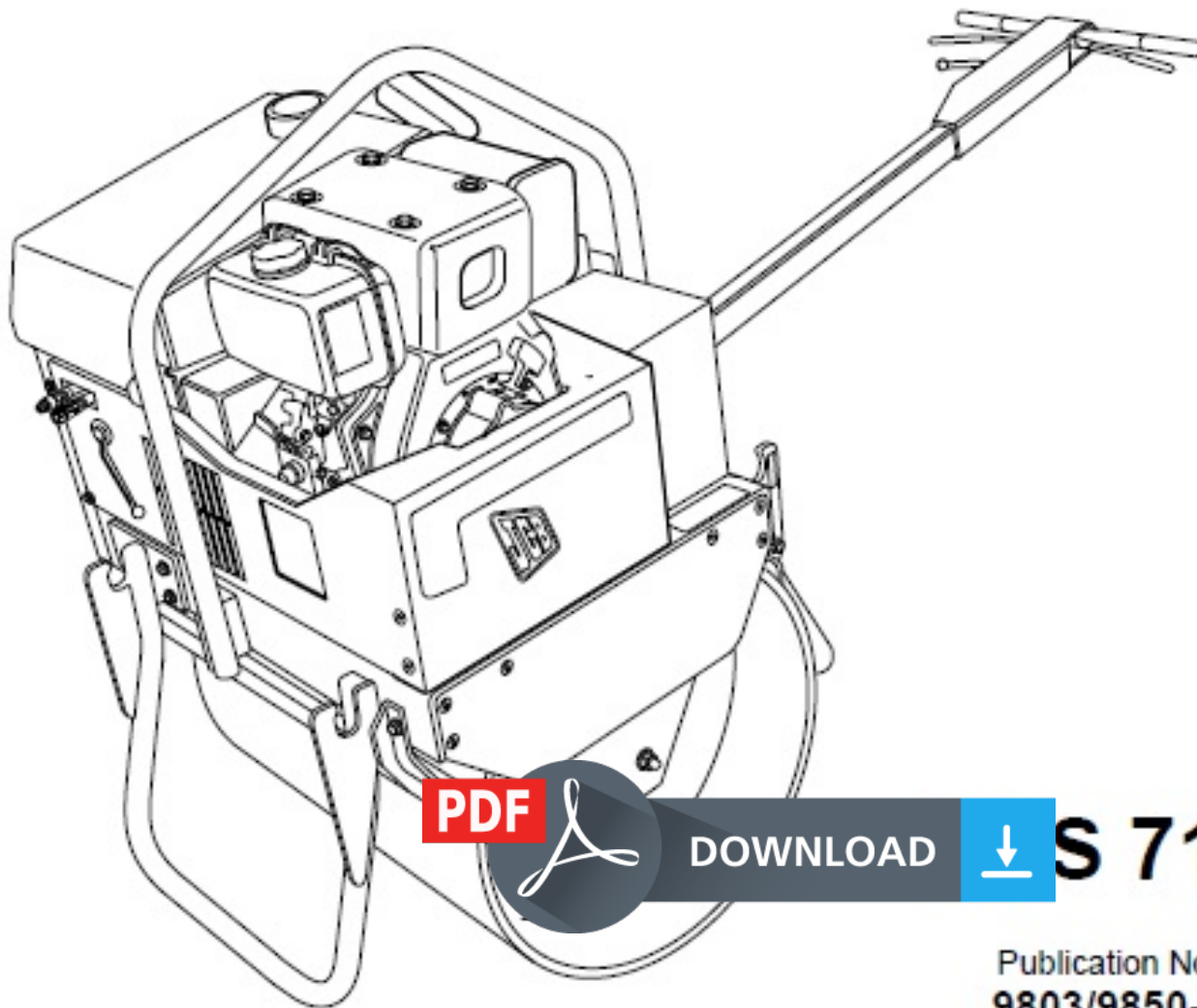

PDF  **DOWNLOAD**  **S 71**

Publication No.
9803/9850-1

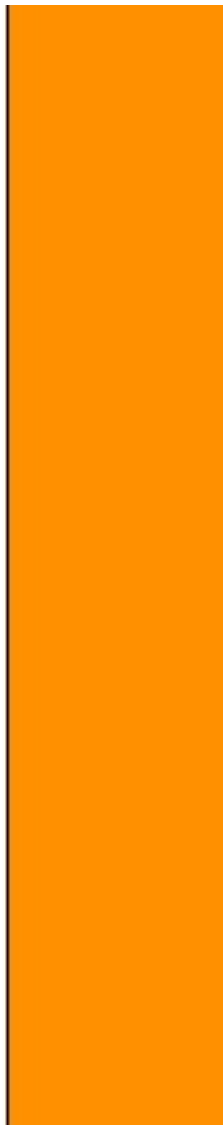

JCB VMS 71 , 71-20 , 71-30 Single Drum Roller Service Repair Manual (VMS71 Series)

Download Complete Service Repair Manual for JCB VMS 71 Single Drum Roller.

Publication No. 9803/9850-1

This Factory Workshop Service Manual offers all the service and repair information for JCB VMS 71 Single Drum Roller . With this in-depth & highly detailed manual you will be able to work on your vehicle with the absolute best resources available, which will not only save you money in repair bills but will also help you to look after your investment. The information on this manual covered everything you need to know when you want to repair or service JCB VMS 71 Single Drum Roller.

Models Covered:

This manual provides information for the following model(s) in the JCB machine range:

◆◆◆◆◆◆◆ VMS 71 from SN 1450000 to SN 1450499

◆◆◆◆◆◆◆ VMS 71-20 (20 litre breaker version) from SN 1450500 to SN 1450999

◆◆◆◆◆◆◆ VMS71-30 (30 litre breaker version) from SN 1450500 to SN 1450999

This manual is INSTANT DOWNLOAD. It means no shipping cost or waiting for getting a CD package for several days. You will receive this manual today via instant download on completion of payment via our secure payment processor.

Manual Contents:

Section 1 ◆◆◆ General Information

Section 2 ◆◆◆ Care and Safety

Section 3 ◆◆◆ Routine Maintenance

Section A ◆◆◆ Attachments

Section C ◆◆◆ Electrics

Section E ◆◆◆ Hydraulics

Section F ◆◆◆ Transmission

Section G ◆◆◆ Brakes

Section K ◆◆◆ Engine

Section L ◆◆◆ Vibration

Total Pages: 217

This manual can be used by anyone from a first time owner/amateur to a professional technician. Even the most novice mechanic can also easily follow the step-by-step guides which are made simple by the illustrations and drawings. Keep this manual handy and use it often. Performing routine, preventive maintenance will save you time & money by helping to prevent premature failure and unnecessary repairs.

Your email inbox will receive a download link immediately after your payment is completed

So please make sure your email address is correct.

File Format: PDF

Compatible: All Versions of Windows & Mac



Thank you very much
for your reading.
Please click here
to get more information.