



OPERATOR'S MANUAL

4894 Tractor



REPAIR MANUAL FOR ENGINES

F4GE0484E - F4GE0684F - F4HE0684J



F4GE0484E

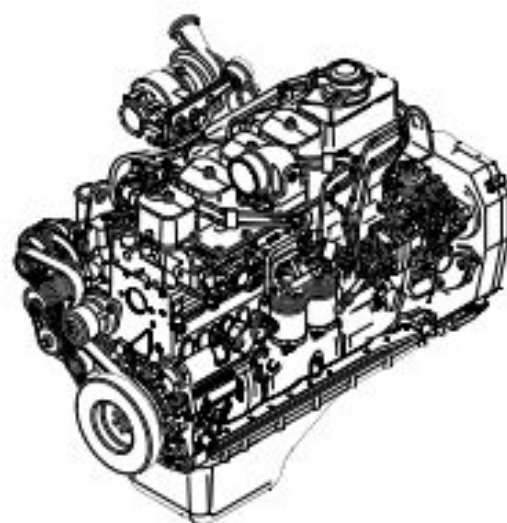

F4GE0684F

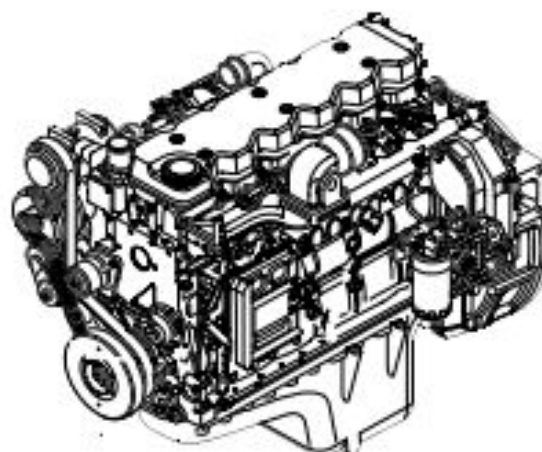

F4HE0684J

Every information, illustration and specification contained in the present manual is based on the most recent information available at the time of printing.

CNH France S.A. reserves the right, to modify the text at any time without prior communication.

ENGINE F4GE0484E OVERHAUL

ENGINE F4GE0484E

Figure 1

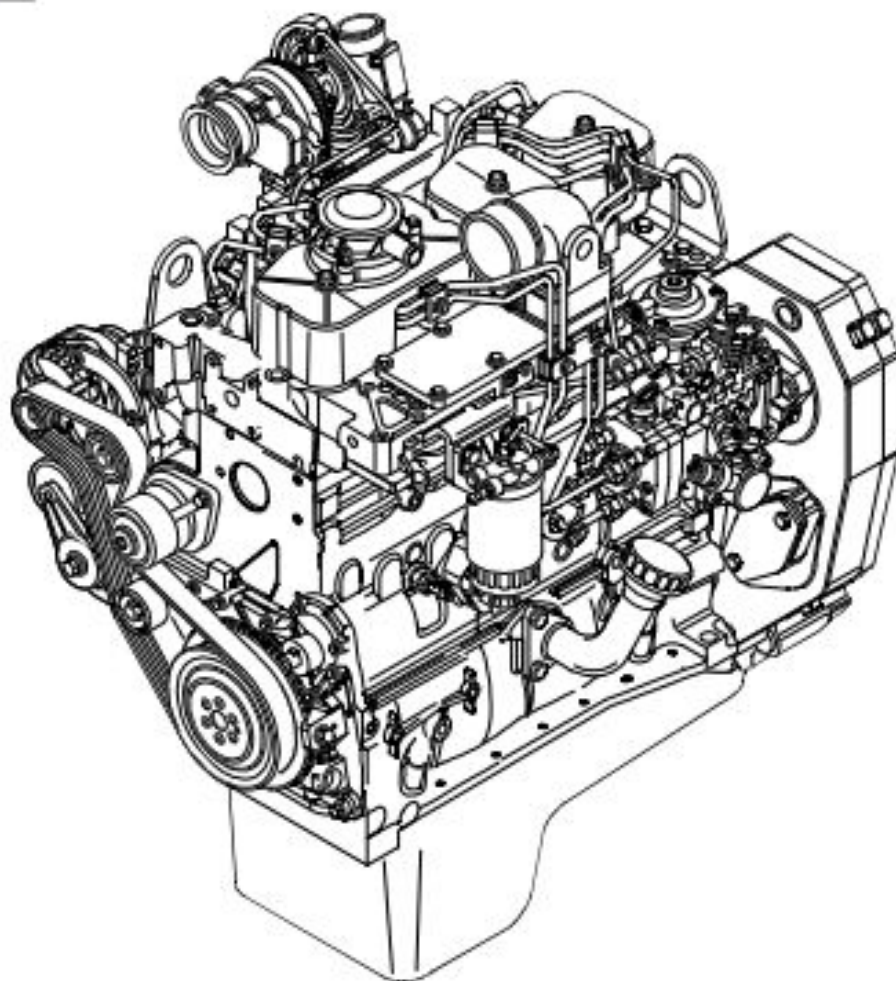

86597

Auxiliary component drive

A Poly-V belt (4) transmits the movement of the crankshaft (5) to the water pump (1) and to the alternator (2).

The belt is stretched by means of automatic belt stretcher (3).

Figure 14

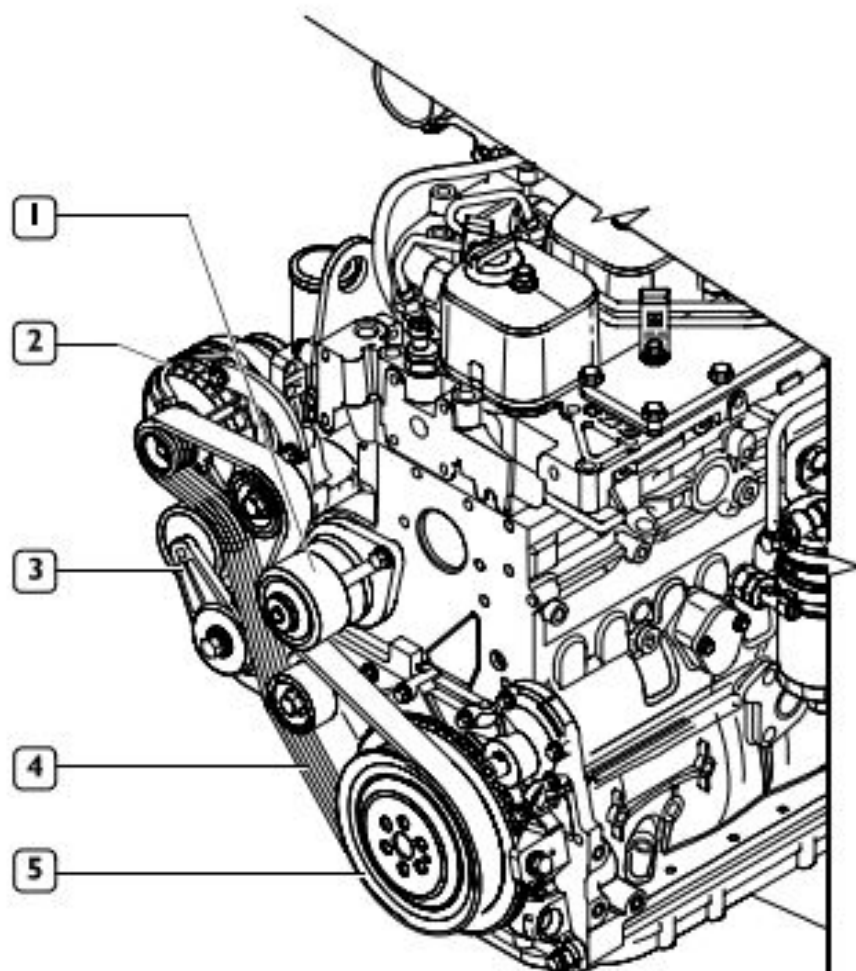

86455

1. Water pump - 2. Alternator - 3. Belt stretcher - 4. Poly-V belt - 5. Drive shaft



Thank you very much
for your reading.
Please click here
to get more information.