



No. 55 Combine



SERVICE MANUAL No. 55 Combine

SM2014 01AUG54 English



SM2014 01AUG54

LITHO IN U.S.A.
ENGLISH



SERVICE MANUAL FOR
JOHN DEERE DEALERS

No. 55 COMBINE

TABLE OF CONTENTS

	Page
INDEX.....	1-4
	Section
Description and Specifications.....	10
Trouble Shooting.....	20
Lubrication.....	30
Tune-Up and Adjustment.....	40
Platform.....	50
Threshing Unit.....	60
Separating Unit.....	70
Cleaning Unit.....	80
Augers and Elevators.....	90
Steering and Rear Axle.....	100
Selective Ground Speed Control.....	105
Axle.....	110
Hydraulic Systems.....	120



INTRODUCTION

This Service Manual contains maintenance instructions on the John Deere No. 55 Combine. Included are complete instructions for adjustment, removal, inspection, repair, assembly, and installation of all assemblies.

The manual contains brief descriptions of the more complicated units of the combine. A comprehensive trouble shooting section has been included that will enable a serviceman to trace the cause of trouble easily and quickly. Adjustments required to keep the combine operating at full efficiency are explained in detail.

Service of the engine used on the No. 55 Combine is covered in SM-2014 which is on the Hercules QXD-3 engine used on both the No. 55 Combine and the No. 8 Cotton Picker.

This Service Manual was planned and written for the Service Department; its place is in the shop. Use the manual whenever in doubt about correct maintenance procedures. Use it as a text book for training new Service Department personnel who may be unfamiliar with John Deere combines.

Daily use of the Service Manual as a guide for any and all service problems will reduce error and costly delay to the minimum and assure you the best in finished service work. In many instances your customer's confidence in your work will be improved when he sees you using the Service Manual. He knows you are following approved maintenance procedures and making proper adjustments. There is no guesswork when you use the Manual.

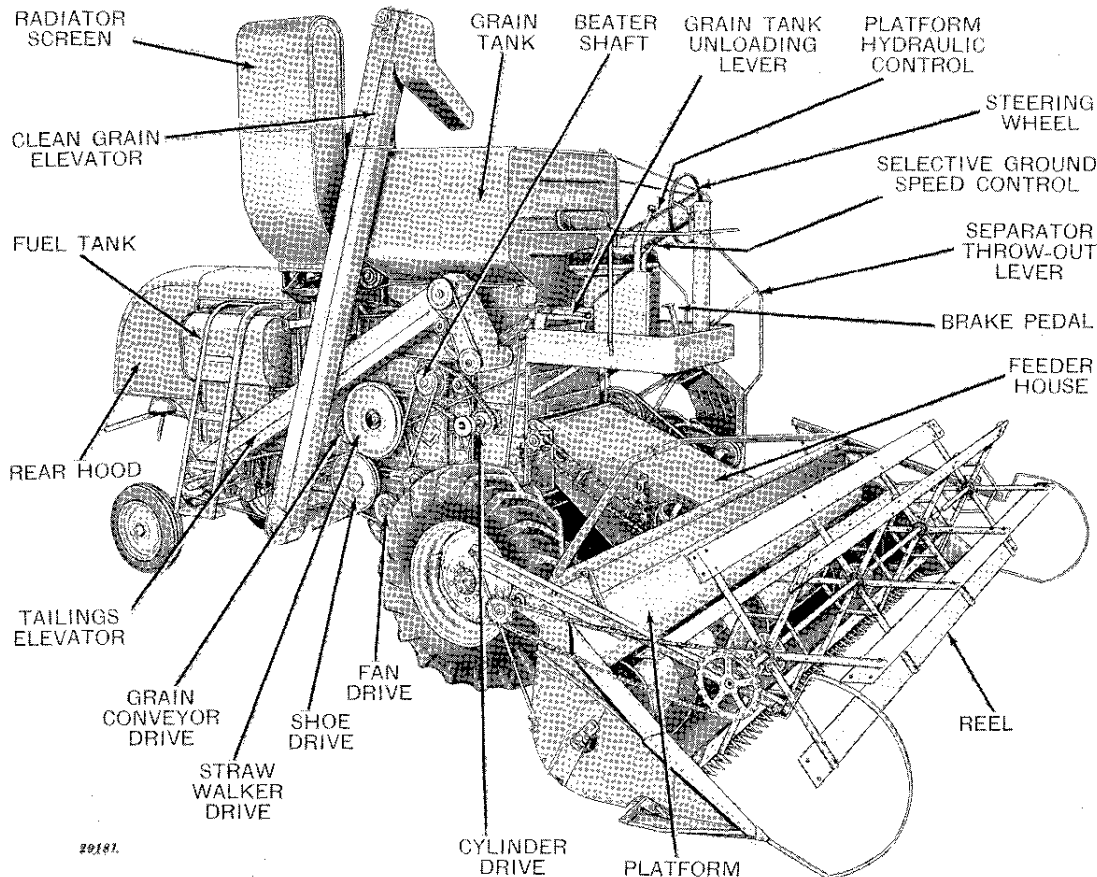

John Deere No. 55 Self-Propelled Combine

INDEX

A	<i>Page</i>		<i>Page</i>
Air Cleaner	30-5-2	Cleaning Fan	80-15-1
Auger Adjustments	50-20-2, 90-10-1	Cleaning Fan Repair	80-15-2
Augers and Elevators	40-5-1	Cleaning, Inspection and Repair, Steering Gear	100-10-5
Auger and Sickle Speeds	50-5-3	Cleaning Unit Adjustments	80-10-2
Auger Drive	90-5-3	Cleaning Unit, Description	80-5-1
Auger Drive Belts	40-5-10	Clean-Out Doors	90-5-1
Auger Drive Belt Adjustments	90-10-1	Clutch	110-5-2
Auger, Platform	50-20-1	Clutch Adjustment	40-5-21, 110-20-4
Auger, Repair	50-20-5	Clutch Assembly	110-20-3
Auger Replacement	50-20-5	Clutch Disassembly	110-20-2
Auger Shaft Shield	40-5-9	Clutch Inspection and Repair	110-20-3
Auger Slip Clutches	40-5-10	Clutch Installation	110-20-4
Auger Stripper	40-5-4	Clutch Plate, Centering	40-5-11
Axle Description	110-5-1	Clutch Removal	110-20-1
Axle Inspection and Diagnosis	110-10-1	Clutch, Unloading Auger	90-10-2
Axle Installation	110-15-2	Concave Grate, Description	60-15-1
Axle with Planetary Gears	110-35-3	Concave Grate, Inspection and Repair	60-15-3
Axle, Regular	110-35-1	Concave Grate Removal	60-15-1
Axle Removal	110-15-1	Controls	10-5-8
Axles and Wheel Hubs	110-5-5	Conveyor Chain Tension	40-5-9, 90-5-2
		Conveyor Feeder	40-5-5, 50-30-1
B		Conveyor, Grain	70-5-2
Backlash of Studs in Cam Groove	40-5-15	Crankshaft Replacement	70-20-3
Ball Sockets, Knife Drive	40-5-2	Cutter Bar	40-5-1
Ball Thrust Bearings Adjustment	40-5-5	Cutter Bar Knife	50-15-1
Bearing Preload	110-30-8	Cutter Bar Knife Register	40-5-1
Beater	70-10-1	Cutter Bar Repair	50-15-2
Beater Behind the Cylinder	40-5-7	Cylinder	40-5-6
Beater, Feeder, Replacement	50-25-2	Cylinder Adjustments	60-10-1
Beater Replacement	70-10-1	Cylinder Drive	60-10-10
Beater Speed	40-5-7	Cylinder Installation	60-10-5
Blackhawk Cylinder Service	120-25-3	Cylinder, Platform Lift	120-25-1
Brakes, Hydraulic	40-5-20	Cylinder Removal	60-10-5
Brakes, Mechanical	40-5-19	Cylinder Repair	60-10-10
Brake, Transmission	110-25-1	Cylinder Replacement	60-10-4
Bushings, Rubber, Shoe Hanger, and Pitman	80-10-5	Cylinder Shaft Replacement	60-10-9
		Cylinder Speeds	60-10-11 – 60-10-13
C		Cylinder Stripper Adjustment	40-5-6
Capacities, Lubricant	30-5-1		
Centering the Clutch Plate	40-5-11	D	
Cessna Cylinder Service	120-25-4	Description and Specifications	10-5-1
Chaffer and Sieve Equipment, Special	80-10-3	Differential	110-5-5
Chaffer and Sieve Replacement	80-10-4	Differential Assembly	110-30-4
Chaffers	80-5-2	Differential Bearing Preload, Adjusting	110-30-8
Chain, Feeder Conveyor	80-30-6	Differential Carrier Disassembly	110-30-2
		Differential Inspection and Repair	110-30-3



Thank you very much
for your reading.
Please click here
to get more information.