

John Deere 470GLC (SN.from D473001) Excavator Service Repair Technical Manual (TM14155X19)

470GLC Excavator Repair

(PIN: 1FF470GX__D473001—)



JOHN HARE



COLLECTION

REPAIR TECHNICAL MANUAL 470GLC Excavator (PIN: 1FF470GX__D473001—)

TM14155X19 01DEC18 (ENGLISH)

For complete service information also see:

470GLC Excavator Operation and Test..... TM14154X19



Worldwide Construction and
Forestry Division

Covers: 470GLC,1FF470GX__,D473001 (???)

Type: Service Manual

Language: English

Pages: 386

Format: PDF

Features: Bookmarked, searchable, printable

Compatibility: Windows/Mac/Tablet/Mobile

This service manual contains important information for the maintenance, troubleshooting and servicing of the **John Deere 470GLC (SN.from D473001) Excavator Service Repair Technical Manual (TM14155X19)**

In this manual you will find detailed specifications, illustrations, schematics, diagrams and step-by-step procedures to properly service and diagnose the machine to the manufacturer's standards.

Contents:

- General Information
- Specifications
- Serial Number Location
- Engine Specifications
- Engine Diagnostics
- Engine Tests and Adjustments
- Engine Repair
- Power Train
- Transmission
- Axles
- Differential
- PTO
- Hydraulic System
- Electrical System
- Electrical Tests and Diagnostics
- Wiring Diagram / Schematic
- Ignition and Charging
- Steering
- Brakes
- Wheels
- Operator's Platform
- Body Panels
- Disassembly and Assembly
- Diagnostics, Tests and Adjustments
- Troubleshooting
- and much more...

Please note this manual is in **downloadable PDF format only**. If you have any questions about this product or would like to request sample pages, please contact us and reference the product name or SKU.

Track Chain Repair to Replace Broken Part

NOTE:

This procedure is to address a broken track pin or broken track link.

Broken Track Pin Replacement

1. Remove three track shoes surrounding damaged area. [See Track Shoe Remove and Install](#). (Group 0130.)

2. NOTE:

All track pins, bushings, and links will be discarded and replaced with new parts.

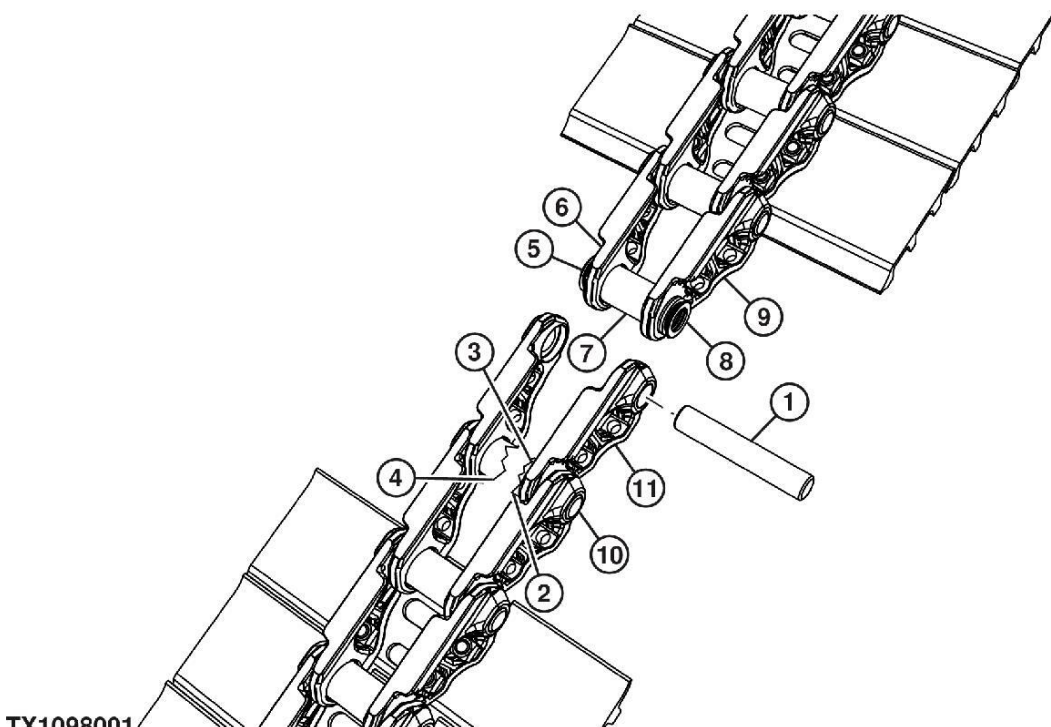

TX1098001

TX1098001-UN: Track Pin

LEGEND:

1-Broken Track Pin
2-Bushing
3-Cut Point
4-Cut Point
5-Grind Point
6-Track Link

7-Bushing
8-Grind Point
9-Track Link
10-Track Pin
11-Track Link Assembly

Remove broken track pin (1).

IMPORTANT:

3. **Avoid damage to good parts. Use care when operating cutting torch.**

Cut bushing (2) and pin at cut points (3 and 4).



Thank you very much
for your reading.
Please click here
to get more information.