

John Deere 325G Compact Track Loader Repair Technical Manual - TM14297X19

325G Compact Track Loader Repair

PIN: 1T0325G__G328658—



JOHN HARE



COLLECTION

REPAIR TECHNICAL MANUAL 325G Compact Track Loader

(PIN: 1T0325G__G328658—)

TM14297X19 01DEC19 (ENGLISH)

For complete service information also see:

325G Compact Track Loader Diagnostic	TM14293X19
4TNV98 and 4TNV98T Diesel Engines	ctm130319
Hydraulic Cylinders	ctm120519



Worldwide Construction and
Forestry Division

Covers: 325G,1T0325G__,G328658(???)

Type: Service Manual

Language: English

Pages: 262

Format: PDF

Features: Bookmarked, searchable, printable

Compatibility: Windows/Mac/Tablet/Mobile

This service manual contains important information for the maintenance, troubleshooting and servicing of the **John Deere 325G Compact Track Loader Repair Technical Manual - TM14297X19**

In this manual you will find detailed specifications, illustrations, schematics, diagrams and step-by-step procedures to properly service and diagnose the machine to the manufacturer's standards.

Contents:

- General Information
- Specifications
- Serial Number Location
- Engine Specifications
- Engine Diagnostics
- Engine Tests and Adjustments
- Engine Repair
- Power Train
- Transmission
- Axles
- Differential
- PTO
- Hydraulic System
- Electrical System
- Electrical Tests and Diagnostics
- Wiring Diagram / Schematic
- Ignition and Charging
- Steering
- Brakes
- Wheels
- Operator's Platform
- Body Panels
- Disassembly and Assembly
- Diagnostics, Tests and Adjustments
- Troubleshooting
- and much more...

Please note this manual is in **downloadable PDF format only**. If you have any questions about this product or would like to request sample pages, please contact us and reference the product name or SKU.

Track Remove and Install

SPECIFICATIONS

Engine Speed	Slow Idle
Individual Track Weight (approximate)	214 kg 471 lb.

SERVICE EQUIPMENT AND TOOLS

38—51 mm (1.5—2.0 in.) Diameter Steel Pipe (3 used)

1. Remove front attachment and park machine on flat, level surface.
2. Raise and block machine. [See Raising and Blocking Machine](#). (Group 1740.)
3. Raise boom and engage boom lock. See Boom Lock - document OMT396975X19 - (Operators Manual.)
4. Remove track adjuster cover plate from track frame.



5. **CAUTION:** Prevent possible injury from high pressure grease in track adjuster cylinder. DO NOT loosen track adjuster valve (2) too quickly or too much. Never loosen grease fitting (1) to release grease.



T211663A-UN: Track Adjuster Valve

LEGEND:

- 1-Grease Fitting
- 2-Track Adjuster Valve

Slowly loosen track adjuster valve (2) 1—2 turns to discharge grease from track adjuster cylinder. Allow track to sag completely.

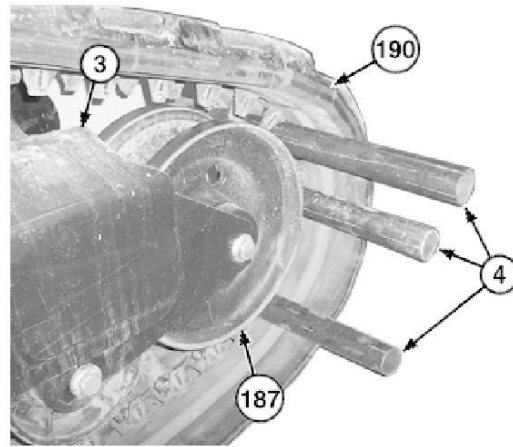

6. TX1132015A-UN: Track Removal

LEGEND:

- 3-Track Frame
- 4-Steel Pipe (3 used)
- 187-Front Idler
- 190-Track

Lay three 38—51 mm (1.5—2.0 in.) diameter steel pipes (4) evenly spaced on track (190), below track frame (3).



7. **CAUTION:** Prevent possible injury from moving tracks or steel pipes. Run engine at slow idle and have any bystanders stand at a safe distance from steel pipes while moving drive sprocket.

Start engine and run at specification.

Item	Measurement	Specification
Engine	Speed	Slow Idle

8. Slowly rotate drive sprocket in reverse direction until track is raised off of front idler (187) by steel pipes.
9. Stop engine.



10. **CAUTION:** Prevent possible crushing injury from heavy component. Use appropriate lifting device.

Using appropriate lifting device, pry and slide track away from front idler and track frame to remove.

Item	Measurement	Specification
Individual Track	Weight (approximate)	213 kg 471 lb.

11. Clean and inspect track components.
 - a. Inspect lugs and area between lugs for cracks that exceed 3 mm (0.1 in.) in depth, reach steel core, or exceed 30 mm (1.2 in.) in length.
 - b. Inspect for any signs of exposed steel core.
 - c. Inspect roller side of track for cracks that reach steel core. Inspect for separation of steel core anywhere on track.
12. Install track on drive sprocket teeth and rear idler. Slip front end over front idler.
13. Lay three 38—51 mm (1.5—2.0 in.) diameter steel pipes evenly spaced on track, below track frame.

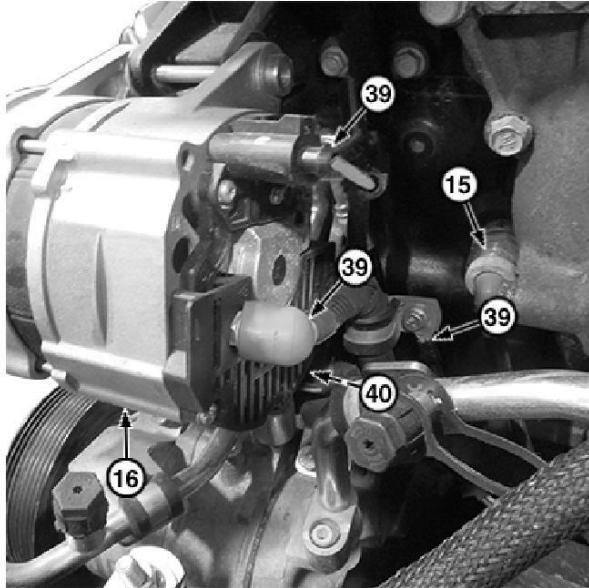

9. TX1257419A-UN: Alternator Electrical Connectors

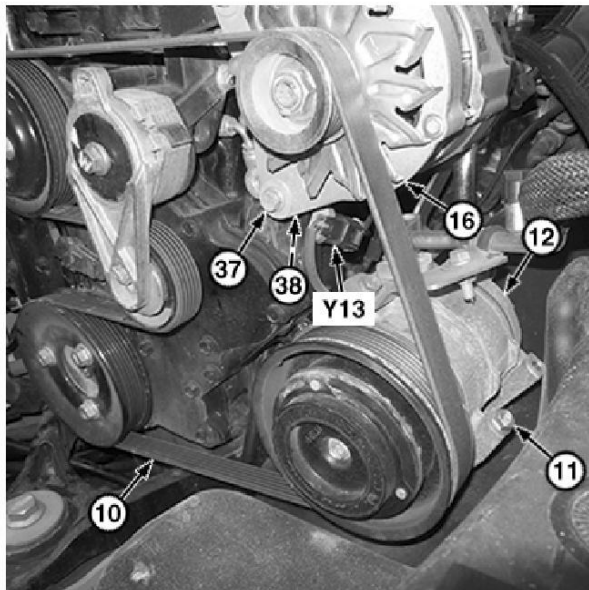

TX1257406A-UN: Air Conditioner Compressor (if equipped)

LEGEND:

- 10-Accessory Drive Belt**
- 11-Cap Screw (3 used)**
- 12-Air Conditioner Compressor (if equipped)**
- 15-Block Heater (if equipped)**
- 16-Alternator**
- 37-Cap Screw (2 used)**
- 38-Spacer (2 used)**
- 39-Electrical Connector (3 used)**
- 40-Nut**
- Y13-Air Conditioner Compressor Clutch Solenoid**

Disconnect electrical connectors (39) from alternator (16).

10. Remove nut (40).
11. Disconnect block heater (if equipped) (15) from engine.
12. Remove accessory drive belt (10). See Replacing Accessory Drive Belt - document OMT396975X19 - (Operator's Manual.)
13. Remove cap screws (37), spacers (38), and alternator.
14. Disconnect air conditioner compressor clutch solenoid (Y13).

15. NOTE:

It is not necessary to disconnect air conditioner lines when removing compressor from engine.

Remove cap screws (11) and set air conditioner compressor (if equipped) (12) aside.

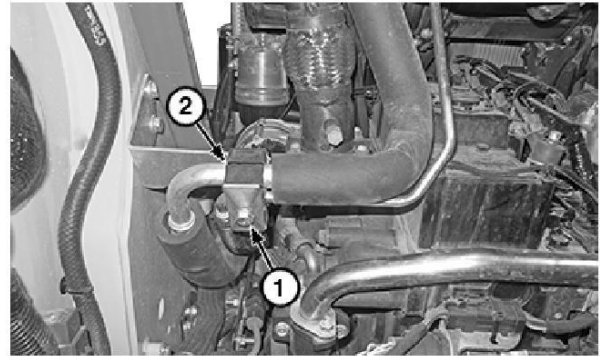

16. TX1255873A-UN: Air Conditioner Lines

LEGEND:

- 1-Cap Screw**
- 2-Clamp**

Remove cap screw (1) and clamp (2).

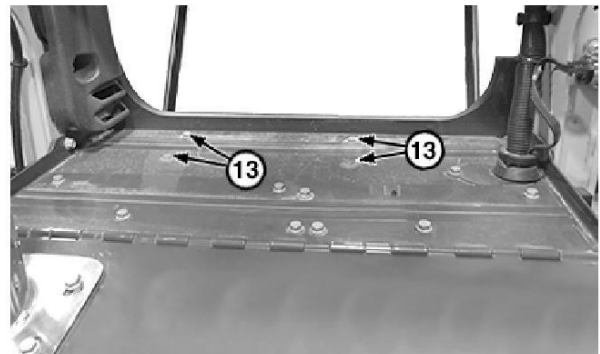

17. TX1255897A-UN: Air Conditioner and Heater (top view)



TX1255898A-UN: Air Conditioner and Heater (left side view)

LEGEND:

- 13-Cap Screw (5 used)**
- 14-Air Conditioner and Heater Assembly**

Using appropriate lifting device, support air conditioner and heater assembly (14).

18. Remove cap screws (13) and set air conditioner and heater assembly aside.



Thank you very much
for your reading.
Please click here
to get more information.