

Book code No.

S7L00017E

KOBELCO

Hydraulic Excavator

MARK V

SERVICEMAN HANDBOOK

SK60v LE-17701 ~

SK100v YW-06501 ~

SK120v LP-11001 ~

SK120LCV YP-02301 ~

SK200v  **DOWNLOAD** 

SK200LCV YQ-02301 ~

SK220v LQ-03301 ~

SK220LCV LL-02301 ~

PRINTED IN JAPAN.
1997/04

CONTENTS

| | |
|--|------|
| 1. GENERAL DIMENSIONS | 1 |
| 2. MACHINE SPECIFICATION TABLE | 2 |
| 3. MAJOR SPECIFICATIONS | |
| 3-1 ENGINE SPECIFICATIONS, CHARACTERISTIC CURVE..... | 4 |
| 3-2 HYDRAULIC COMPONENTS | 14 |
| 3-3 HYDRAULIC CYLINDER LIST | 16 |
| 4. PERFORMANCE TABLE | 18 |
| 5. WEIGHT OF COMPONENTS | 19 |
| 6. CAPACITY TABLE OF LUBRICATION OIL AND COOLANT | 23 |
| 7. LIST OF FILTER AND ELEMENT | 23 |
| 8. SPECIFIED OIL AND GREASE, AND FILTER ELEMENT LIST | 24 |
| 9. PROCEDURES FOR MEASURING AND ADJUSTING PRESSURE | 34 |
| 10. HYDRAULIC OIL PUMP CONTROL CURVE | 51 |
| 11. MECHATRO CONTROLLER | |
| 11-1 INDICATION OF MULTI-PURPOSE DISPLAY SERVICE DIAGNOSIS..... | 55 |
| 11-2 CLUSTER GAUGE CONNECTOR | 56 |
| 11-3 SERVICE DIAGNOSIS INDICATION ITEMS..... | 57 |
| 11-4 INDICATION OF MULTI-PURPOSE DISPLAY SELF DIAGNOSIS... | 59 |
| 11-5 FAILURE HISTORY FUNCTION | 63 |
| 11-6 MECHATRO "A" ADJUSTMENT | 64 |
| 11-7 TROUBLE-SHOOTING | 67-1 |
| 12. HYDRAULIC SYSTEM DIAGRAM..... | 68 |
| 13. ELECTRIC CIRCUIT DIAGRAM | 82 |
| 14. DIMENSIONS OF ATTACHMENTS | 92 |
| 15. MAINTENANCE STANDARD | |
| 15-1 PIN AND BUSHING TABLE OF ATTACHMENT | 102 |
| 15-2 RESINOID SHIM TABLE OF ATTACHMENT | 123 |
| 15-3 UNDER CARRIAGE..... | 124 |
| 16. WORKING RANGES OF ATTACHMENT | 130 |
| 17. LIFTING CAPACITY DIAGRAM | 140 |
| 18. REFERENTIAL DATUM | |
| 18-1 TIGHTNING TORQUES FOR NUTS AND SLEEVES..... | 153 |
| 18-2 PIPE JOINT TIGHTENING TORQUE | 154 |
| 18-3 "ORS" JOINT TIGHTENING TORQUE AND HANDLING | 157 |
| 18-4 SPECIAL SPANNER FOR TUBE | 158 |
| 19. CONVERSION TABLE..... | 159 |

SK60v SK120v SK200v SK220v
SK100v SK120LCV SK200LCV SK220LCV

1. GENERAL DIMENSIONS

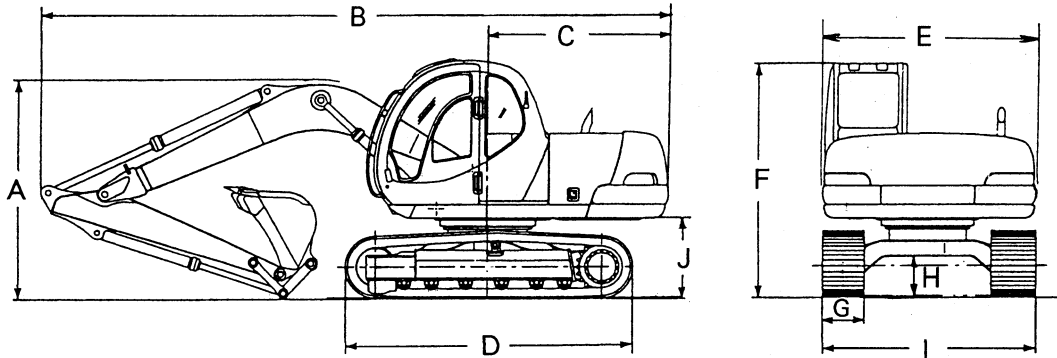

Unit : mm

| MODEL | GENERAL DIMENSIONS | | | | | | | | | | |
|--------------------|--------------------------|-------|--------|--------|---------|-------|-------|-------|---------|---------|-------|
| | ARM | A | B | C | D | E | F | G | H | I | J |
| SK60v | 1,730 (STD) | 2,680 | 6,060 | R1,700 | 2,785 | 2,170 | 2,590 | 450 | 380 | 2,150 | 770 |
| | 2,150 (LONG) | 3,040 | 6,045 | | | | | 600 | | 2,450 | |
| | 1,730+500 (EXTENTION) | 2,890 | 6,055 | | | | | | | | |
| SK100v | 2,220 (STD) | 2,510 | 7,200 | R2,050 | 3,320 | 2,490 | 2,725 | 500 | 455 | 2,490 | 905 |
| | 1,900 (SHORT) | 2,515 | 7,215 | | | | | 600 | | 2,590 | |
| | 2,700 (LONG) | 2,915 | 7,155 | | | | | 700 | | 2,690 | |
| SK120v SK120LCV | 2,500 (STD) | 2,670 | 7,560 | R2,100 | 3,570 | 2,490 | 2,725 | 500 | 455 | 2,490 | 905 |
| | 2,100 (SHORT) | 2,600 | 7,550 | | (3,740) | | | 600 | | 2,590 | |
| | 3,000 (LONG) | 3,050 | 7,520 | | (700) | | | 700 | | (2,490) | |
| | | | | | | | | (600) | | (2,590) | |
| SK200v SK200LCV | 2,940 (STD) | 2,840 | 9,380 | R2,700 | 4,170 | 2,715 | 2,900 | 600 | 465 | 2,800 | 1,055 |
| | 2,400 (SHORT) | 2,995 | 9,470 | | (4,450) | | | 700 | | 2,900 | |
| | 3,300 (LONG) | 2,835 | 9,390 | | (800) | | | 800 | | 3,000 | |
| | | | | | | | | (600) | | (2,990) | |
| SK220v SK220LCV | 2,980 (STD) | 3,080 | 9,990 | R2,850 | 4,350 | 2,840 | 2,930 | 600 | 480 | 2,990 | 1,080 |
| | 2,500 (SHORT) | 3,245 | 10,050 | | (4,650) | | | 700 | | 3,090 | |
| | 3,660 (LONG) | 3,065 | 9,960 | | (800) | | | 800 | | 3,190 | |
| | | | | | | | | (600) | | (3,190) | |
| | | | | | | | (700) | (465) | (2,290) | | |
| | | | | | | | (800) | | (3,390) | | |

NOTE : The values in () shows LC type.

SK60v SK120v
SK100v SK120Lcv

2. MACHINE SPECIFICATION TABLE

| ITEM | MODEL | SK60v | | | SK100v | | | SK120v / SK120Lcv | | |
|--------------------------------------|---|---|----------|-----------|---|----------|-------|---|---------------------|---------------------|
| PERFORMANCE | | | | | | | | | | |
| STD bucket capacity | m ³ | 0.25 | | | 0.4 | | | 0.45 | | |
| Bucket capacity range | m ³ | 0.1~0.3 | | | 0.15~0.45 | | | 0.22~0.6 | | |
| Travel speed | km/h | 5.5/3.5/2.5 (Low speed, FC mode) | | | 7.0~1.0 | | | 7.0~1.0 | | |
| Swing speed | rpm | 13/6.5 | | | 12/4.0 | | | 12/4.0 | | |
| Gradeability | ° (%) | 35 (70%) | | | 35 (70%) | | | 35 (70%) | | |
| Travelling | ton | 5.2 | | | 8.5 | | | 9.0 | | |
| Digging force | Bucket | 4.8 | | | 7.7 | | | 8.0 | | |
| | Arm | 3.7 | 3.4 | 3.2 | 6.5 | 5.8 | 5.2 | 7.0 | 6.3 | 5.7 |
| | Arm length | 1,730 | 2,150 | 1,730+500 | 1,900 | 2,220 | 2,700 | 2,100 | 2,500 | 3,000 |
| DIMENSIONS AND WEIGHT | | | | | | | | | | |
| Operating weight | ton | 6.5 (450mm Shoes) | | | 10.6 (500mm Shoes) | | | 11.8 (500mm) | | 12.0 (500mm) |
| Dimensional for Transportation | Arm length | 1,730 | 2,150 | 1,730+500 | 1,900 | 2,220 | 2,700 | 2,100 | 2,500 | 3,000 |
| | Full length | 6,060 | 6,045 | 6,055 | 7,215 | 7,200 | 7,155 | 7,550 | 7,560 | 7,520 |
| | Full width | 2,170 | 2,170 | 2,170 | 2,490 | 2,490 | 2,490 | 2,490 | 2,490 | 2,490 |
| | Full height | 2,680 | 3,040 | 2,890 | 2,725 | 2,725 | 2,915 | 2,725 | 2,725 | 3,050 |
| Upper | Cab height from G.L. | 2,590 | | | 2,725 | | | 2,725 | | |
| | Tail height from G.L. | 770 | | | 905 | | | 905 | | |
| | Tail swing radius | 1,700 | | | 2,050 | | | 2,100 | | |
| | Min. front swing radius | 1,625 | | | 2,340 | | | 2,390 | | |
| Lower | Overall length of crawlers | 2,785 | | | 3,320 | | | 3,570 | | 3,740 |
| | Crawler wheel centers | 2,160 | | | 2,610 | | | 2,865 | | 3,035 |
| | Track gauge | 1,700 | | | 1,990 | | | 1,990 | | 1,990 |
| | Overall width of crawlers | 2,150 | | | 2,490 | | | 2,490 | | 2,490 |
| | Width of shoes ground pressure mm/kgf/cm ² | Grouser | 450/0.30 | | Grouser | 500/0.37 | | Grouser | 500/0.39 : 500/0.37 | |
| | | | 600/0.23 | | | 600/0.32 | | | 600/0.33 : 600/0.31 | |
| Flat | | 450/0.31 | | Flat | 500/0.38 | | Flat | 500/0.39 : 500/0.37 | | |
| | | Triangle | 600/0.23 | | 700/0.20 | Triangle | | 800/0.24 | Triangle | 800/0.25 : 800/0.24 |
| Ground clearance | mm | 380 | | | 455 | | | 455 | | |
| ENGINE | | | | | | | | | | |
| Model | | ISUZU 4JB1 | | | ISUZU 4BD1 | | | ISUZU 4BDIT | | |
| Rated power output | PS/rpm | 57/2,200 | | | 76/2,300 | | | 85/2,100 | | |
| Max. torque | kgf·m/rpm | 19.2/1,600 | | | 24/1,600 | | | 30.5/1,600 | | |
| Displacement | cc | 2,771 | | | 3,856 | | | 3,856 | | |
| Capacity of fuel tank | ℓ | 130 | | | 250 | | | 250 | | |
| HYDRAULIC SYSTEM | | | | | | | | | | |
| Type of pumps | | Two axial-piston, variable displacement pumps+gear pump | | | Two axial-piston, variable displacement pumps+gear pump | | | Two axial-piston, variable displacement pumps+gear pump | | |
| Set pressure of system | kgf/cm ² | 260/320 (Travel) | | | 330 | | | 350 | | |
| Swing motor | | Axial piston | | | Axial piston | | | Axial piston | | |
| Travel motor | | Axial piston | | | Axial piston | | | Axial piston | | |
| Control valves | | 6-spool | | | 6-spool | | | 6-spool | | |
| Capacity of HYD. oil tank | ℓ | 50 | | | 100 | | | 100 | | |
| WORKING RANGES | | | | | | | | | | |
| Length of Arm | mm | STD | LONG | EXT. | SHORT | STD | LONG | SHORT | STD | LONG |
| | | 1,730 | 2,150 | 1,730+500 | 1,900 | 2,220 | 2,700 | 2,100 | 2,500 | 3,000 |
| Bucket capacity | m ³ | 0.25 | 0.2 | 0.2 | 0.45 | 0.4 | 0.32 | 0.5 | 0.45 | 0.33 |
| Max. digging reach | mm | 6,390 | 6,780 | 6,840 | 7,400 | 7,700 | 8,160 | 7,920 | 8,270 | 8,730 |
| Max. digging depth | mm | 4,200 | 4,610 | 4,690 | 4,780 | 5,100 | 5,580 | 5,200 | 5,600 | 6,100 |
| Max. vertical wall digging depth | mm | 3,600 | 3,960 | 4,090 | 4,230 | 4,560 | 5,020 | 4,600 | 4,980 | 5,400 |
| Max. digging height | mm | 7,400 | 7,720 | 7,760 | 7,820 | 8,040 | 8,350 | 8,350 | 8,520 | 8,800 |
| Max. dumping clearance | mm | 5,340 | 5,650 | 5,690 | 5,440 | 5,650 | 5,960 | 5,900 | 6,090 | 6,370 |

SK 200v SK 220v
SK 200Lcv SK 220Lcv

| ITEM | MODEL | SK200v/SK200Lcv | | | SK220v/SK220Lcv | | | | |
|----------------------------------|--|--|-------------|--------------|--|--------------|-------------|--------------|----------|
| PERFORMANCE | | | | | | | | | |
| STD bucket capacity | m ³ | 0.7 | | | 0.9 | | | | |
| Bucket capacity range | m ³ | 0.45~1.1 | | | 0.7~1.2 | | | | |
| Travel speed | km/h | 7.0~1.0 | | | 7.0~1.0 | | | | |
| Swing speed | rpm | 11/4.0 | | | 11/4.0 | | | | |
| Gradeability | ° (%) | 35 (70%) | | | 35 (70%) | | | | |
| Travelling | ton | 16.3 | | | 18.4 | | | | |
| Digging force | Bucket | 11.8 (Power boost 12.8) | | | 14.2 (Power boost 15.0) | | | | |
| | Arm | ton | 11.3 (12.3) | 9.6 (10.4) | 8.8 | 13.0 (13.7) | 11.2 (11.9) | 9.5 | |
| | Arm length | mm | 2,400 | 2,940 | 3,300 | 2,500 | 2,980 | 3,660 | |
| DIMENSIONS AND WEIGHT | | | | | | | | | |
| Operating weight | ton | 19.0 (600mm) | | 19.5 (600mm) | | 23.0 (600mm) | | 23.6 (600mm) | |
| Dimensions for Transportation | Arm length | mm | 2,400 | 2,940 | 3,300 | 2,500 | 2,980 | 3,660 | |
| | Full length | mm | 9,470 | 9,380 | 9,390 | 10,050 | 9,990 | 9,960 | |
| | Full width | mm | 2,800 | | 2,990 | | 2,990 | | 3,190 |
| | Full height | mm | 2,995 | 2,900 | 2,900 | 3,245 | 3,080 | 3,065 | |
| Upper | Cab height from G.L. | mm | 2,900 | | | 2,930 | | | |
| | Tail height from G.L. | mm | 1,055 | | | 1,080 | | | |
| | Tail swing radius | mm | 2,700 | | | 2,850 | | | |
| | Min. front swing radius | mm | 3,460 | | | 3,900 | | | |
| Lower | Overall length of crawlers | mm | 4,170 | | 4,450 | | 4,350 | | 4,650 |
| | Crawler wheel centers | mm | 3,370 | | 3,650 | | 3,500 | | 3,800 |
| | Track gauge | mm | 2,200 | | 2,390 | | 2,390 | | 2,590 |
| | Overall width of crawlers | mm | 2,800 | | 2,990 | | 2,990 | | 3,190 |
| | Width of shoes ground pressure mm/kgf/cm ² | Grouser | 600/0.43 | 600/0.41 | | Grouser | 600/0.50 | | 600/0.48 |
| | | | 700/0.38 | 700/0.36 | | | 700/0.44 | | 700/0.42 |
| | | | 800/0.33 | 800/0.32 | | | 800/0.39 | | 800/0.37 |
| Flat | | 600/0.44 | | 600/0.42 | | Flat | 600/0.51 | | 600/0.48 |
| Triangle | 900/0.30 | | 900/0.29 | | Triangle | | | | |
| Ground clearance | mm | 465 | | | 480 | | 465 | | |
| ENGINE | | | | | | | | | |
| Model | | MITSUBISHI 6D31-T | | | MITSUBISHI 6D15-T | | | | |
| Rated power output | PS/rpm | 140/2,200 | | | 165/2,100 | | | | |
| Max. torque | kgf·m/rpm | 47/1,700 | | | 60/1,600 | | | | |
| Displacement | cc | 4,948 | | | 6,919 | | | | |
| Capacity of fuel tank | ℓ | 315 | | | 315 | | | | |
| HYDRAULIC SYSTEM | | | | | | | | | |
| Type of pumps | | Two axial-piston, variable displacement pumps+ gear pump | | | Two axial-piston, variable displacement pumps+ gear pump | | | | |
| Set pressure of system | kgf/cm ² | 350 (Power boost 380) | | | 350 (Power boost 370) | | | | |
| Swing motor | | Axial piston | | | Axial piston | | | | |
| Travel motor | | Axial piston | | | Axial piston | | | | |
| Control valves | | 6-spool | | | 6-spool | | | | |
| Capacity of HYD. oil tank | ℓ | 142 | | | 160 | | | | |
| WORKING RANGES | | | | | | | | | |
| Length of Arm | mm | SHORT | STD | LONG | SHORT | STD | LONG | | |
| | | 2,400 | 2,940 | 3,300 | 2,500 | 2,980 | 3,660 | | |
| Bucket capacity | m ³ | 0.8 | 0.7 | 0.6 | 1.0 | 0.9 | 0.7 | | |
| Max. digging reach | mm | 9,420 | 9,900 | 10,220 | 9,890 | 10,310 | 10,970 | | |
| Max. digging depth | mm | 6,190 | 6,700 | 7,090 | 6,530 | 7,010 | 7,690 | | |
| Max. vertical wall digging depth | mm | 5,550 | 6,080 | 6,460 | 5,830 | 6,180 | 6,790 | | |
| Max. digging height | mm | 9,400 | 9,660 | 9,770 | 9,630 | 9,770 | 10,170 | | |
| Max. dumping clearance | mm | 6,560 | 6,830 | 6,970 | 6,710 | 6,870 | 7,250 | | |



Thank you very much
for your reading.
Please click here
to get more information.