



PDF



DOWNLOAD



DX300LC

Shop Manual

K1006409AE

Serial Number 7440 and Up

DOOSAN reserves the right to improve our products in a continuing process to provide the best possible product to the market place. These improvements can be implemented at any time with no obligation to change materials on previously sold products. It is recommended that consumers periodically contact their distributors for recent documentation on purchased equipment.

This documentation may include attachments and optional equipment that is not available in your machine's package. Please call your distributor for additional items that you may require.

Illustrations used throughout this manual are used only as a representation of the actual piece of equipment, and may vary from the actual item.

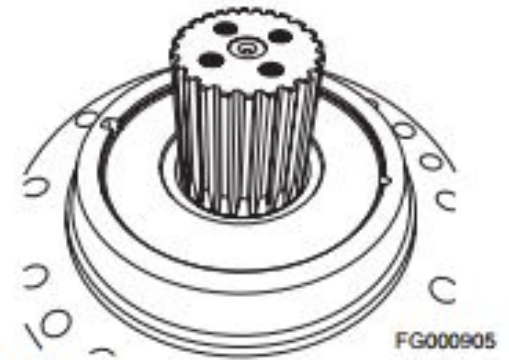

Figure 60

3. Install lock ring in groove of gear case.

NOTE: *Make sure lock ring is inserted completely into groove.*



Figure 61



Figure 62

4. Insert collar on shaft, making sure it is properly seated. Install pinion gear and special jig on shaft, and press collar and pinion gear into place on shaft and case.



Figure 63

4. Tighten bolts to specified torque. Mark them with paint marker.

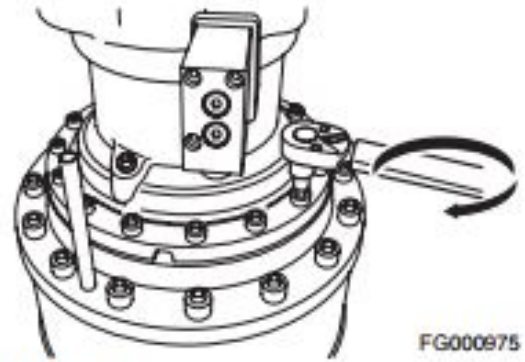

Figure 121



Figure 122

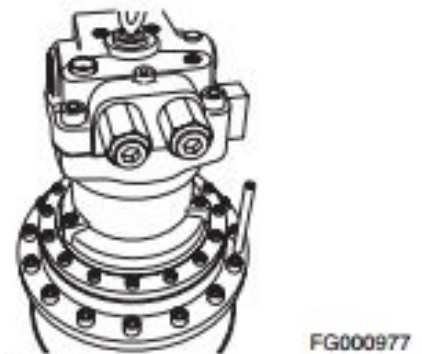

Figure 123

Supply of Grease

1. Install grease fitting in grease inlet and add grease through grease until it starts to be discharged from the opposite hole.

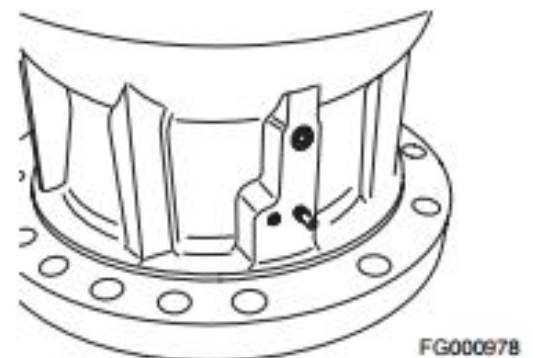

Figure 124



Thank you very much
for your reading.
Please click here
to get more information.