

# 2008 Doosan DX480LC/DX520LC Crawled Excavator Service Repair Workshop Manual



**DOOSAN**

EN

---

# Shop Manual

## DX19 Compact Excavator

---

S/N DBMB3Y8AVF0E11001 & Above

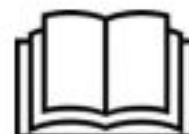
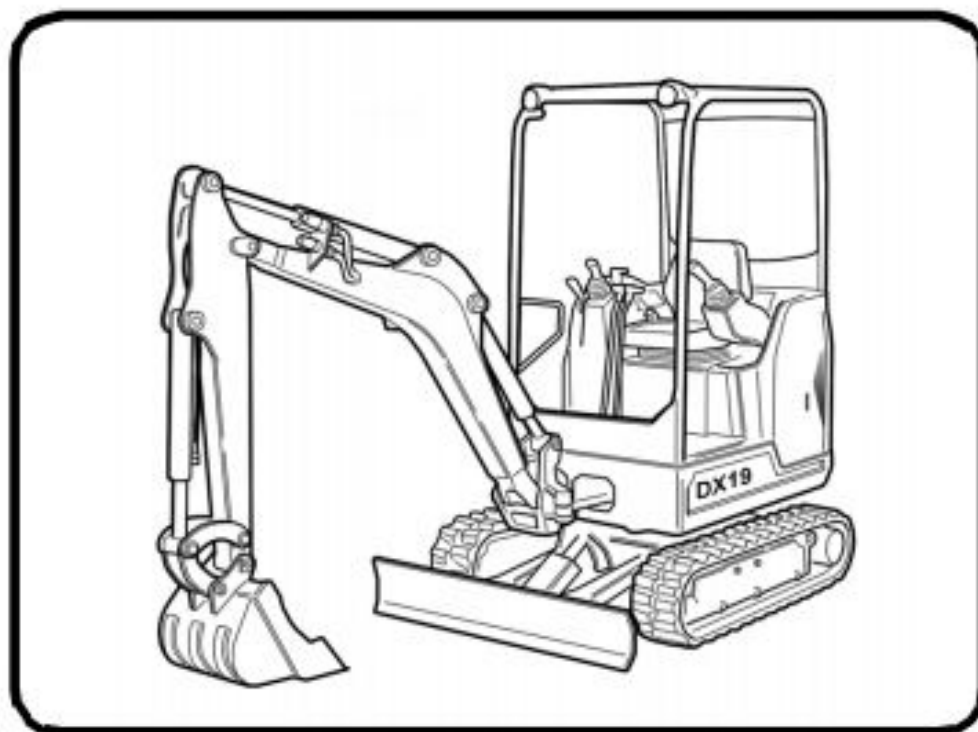

## EXCAVATOR IDENTIFICATION

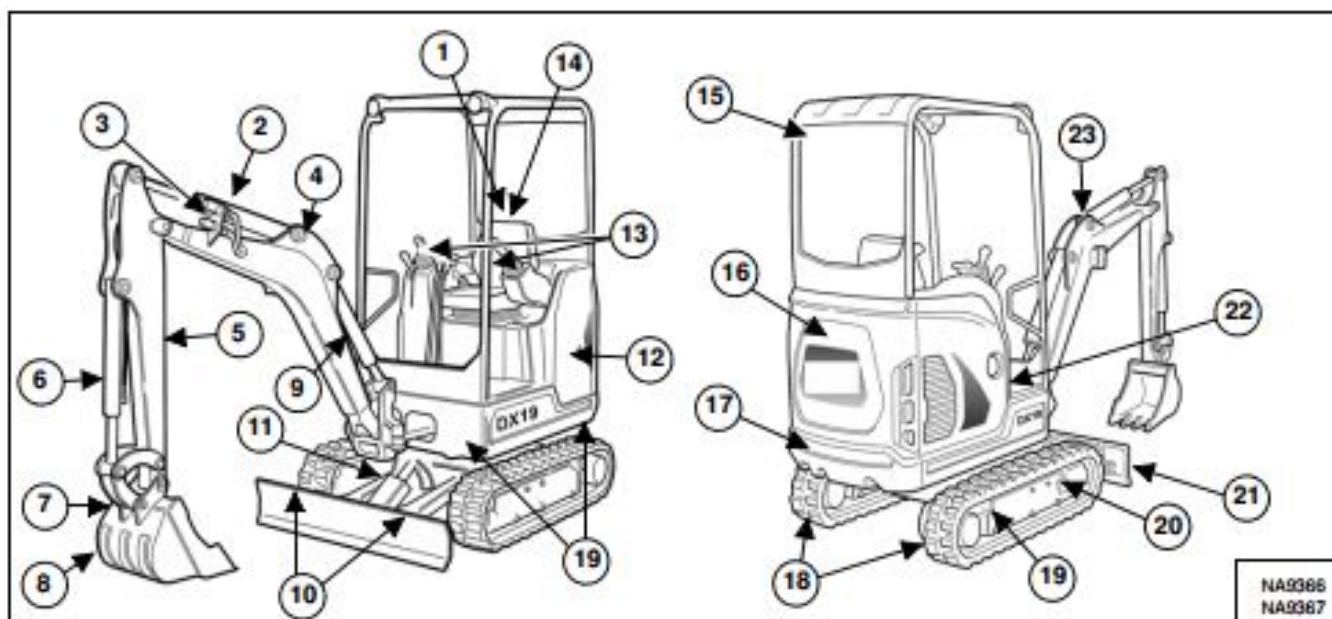

ITEM	DESCRIPTION	ITEM	DESCRIPTION
1	Operator's Handbook (optional)	15	Cab / Canopy (ROPS / TOPS) [B]
2	Arm Cylinder	16	Rear Cover
3	Auxiliary Quick Couplers	17	Counterweight
4	Boom	18	Tracks
5	Arm	19	Tie Downs (Both Sides)
6	Bucket Cylinder	20	Track Frames
7	Bucket Link / Attachment Coupler (If Equipped)	21	Blade
8	Bucket [A]	22	Right Side Cover
9	Boom Cylinder	23	Lift Point
10	Tie Downs / Lift Points		
11	Blade Cylinder		
12	Upperstructure		
13	Control Levers (Joysticks)		
14	Operator's Seat with Seat Belt		

[A] BUCKET - Several different buckets and other attachments are available for the Doosan excavator.

[B] ROPS, TOPS - (Roll-Over Protective Structure / Tip-Over Protective Structure) as standard equipment. The ROPS / TOPS meets ISO 12117-2 AND ISO 12117.



## AIR CLEANER SERVICE

See the service schedule for the correct service interval. (See Maintenance Intervals on Page 10-70-1.)

### Daily Check

The air cleaner is located in the engine compartment. Open the tailgate to access the air cleaner for service.

Figure 10-80-1

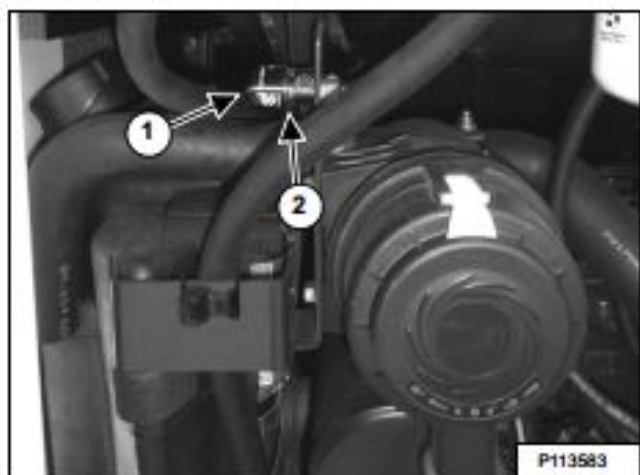

Check the condition indicator (Item 1). If the red ring (Item 2) [Figure 10-80-1] shows in the condition indicator, the filter needs to be replaced.

Replace the inner filter every third time the outer filter is replaced or as indicated.

## Replacing The Filter Elements

### Outer Filter

Figure 10-80-2

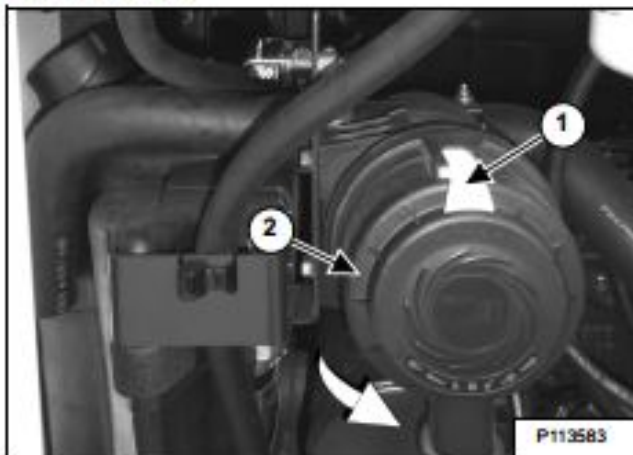

Pull out on the latch (Item 1). Rotate the cover counter clockwise and remove the dust cover (Item 2) [Figure 10-80-2].

Figure 10-80-3

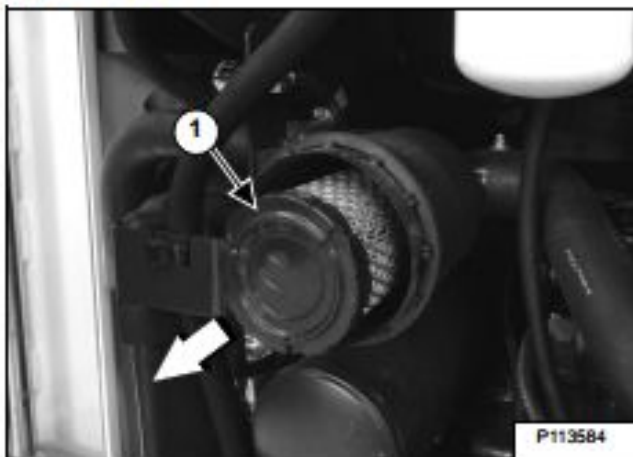

Slightly rotate the filter and pull the outer filter (Item 1) [Figure 10-80-3] from the air cleaner housing.

Check the housing for damage.

Clean the housing and the seal surface. DO NOT use compressed air.

Install a new filter.



Thank you very much  
for your reading.  
Please click here  
to get more information.