

KFA

KFAS with control unit

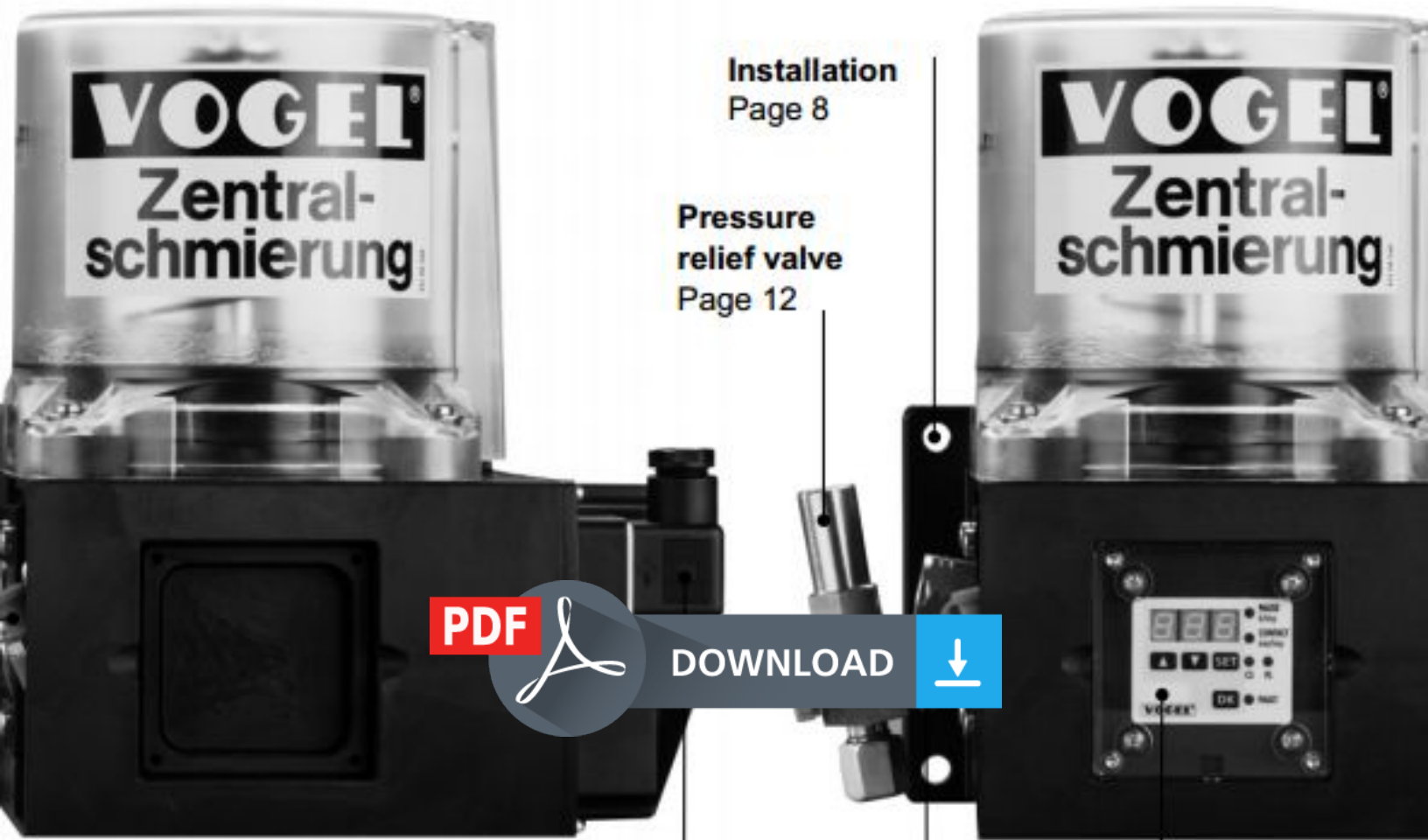

Installation
Page 8

Pressure
relief valve
Page 12

Electrical connection Industrial
applications Page 17

Control general
Page 22

Elect
Page

Pump elements
Page 10

SHOP MANUAL

KOMATSU

PC210, 210LC, 210NLC PC240LC, 240NLC-7K

MACHINE MODEL

PC210-7K

PC210LC-7K

PC210-NLC-7K

PC240LC-7K

PC240NLC-7K

SERIAL NUMBER

K40001 AND UP

K40001 AND UP

K40001 AND UP

K40001 AND UP

K40001 AND UP

- This shop manual may contain attachments and optional equipment that are not available in your area. Please consult your local Komatsu distributor for those items you may require. Materials and specifications are subject to change without notice.

CONTENTS

	No. of page
01 GENERAL	01-1
10 STRUCTURE, FUNCTION AND MAINTENANCE STANDARD	10-1
20 TESTING AND ADJUSTING	20-1
30 DISASSEMBLY AND ASSEMBLY	30-1
90 OTHERS	90-1

ENGINE RELATED PARTS

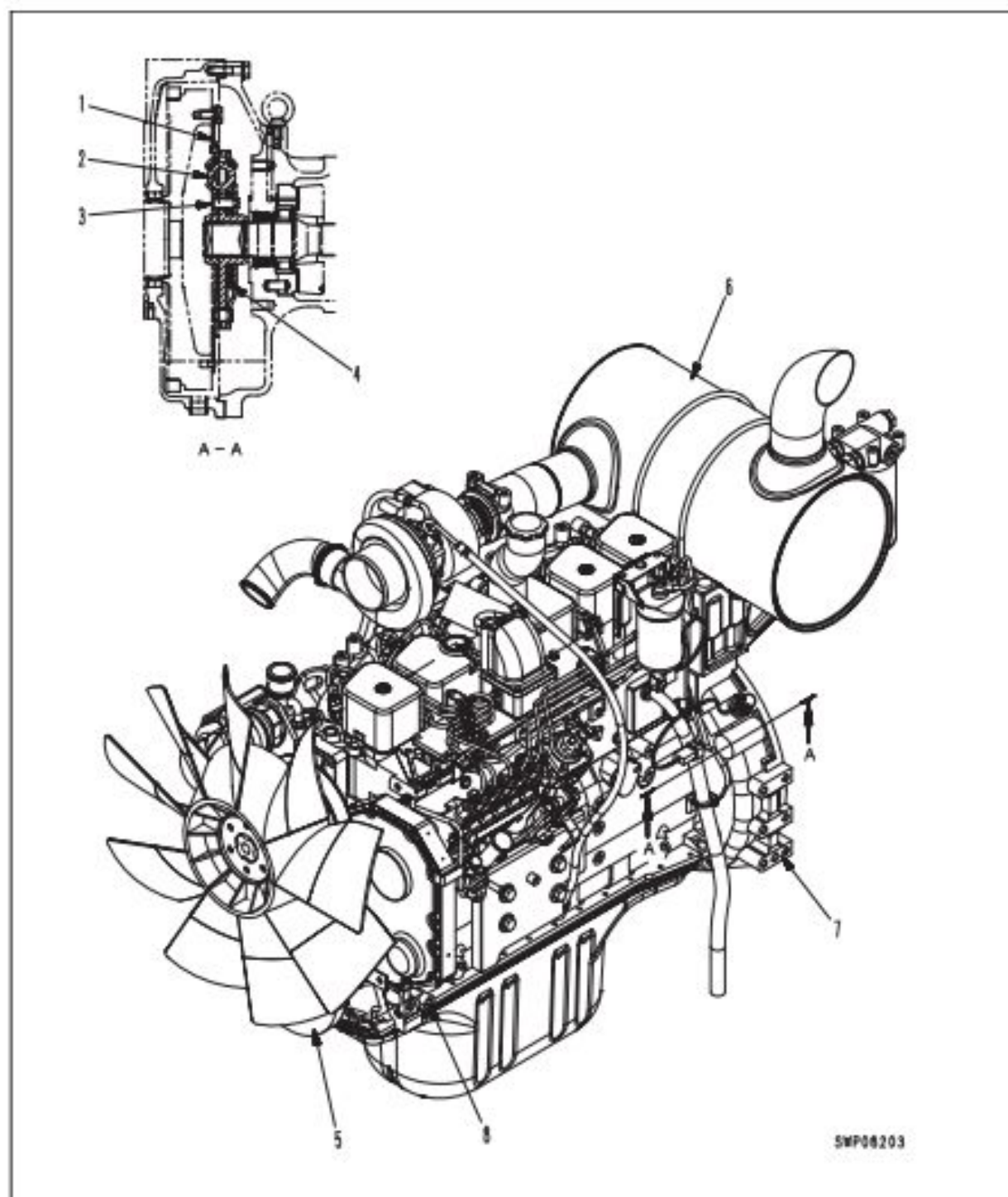

1. Drive plate
2. Torsion spring
3. Stopper pin
4. Friction plate

5. Damper assembly
6. Muffler
7. Rear engine mount
8. Front engine mount

OUTLINE

- The damper assembly is a wet type.
Oil capacity: 0.75 l



Thank you very much
for your reading.
Please click here
to get more information.