

# John Deere 2700, 2800, 2900 Tractors All Inclusive Technical Service Manual (tm1564)

**2700, 2800  
and 2900  
Tractors**



**TECHNICAL MANUAL**  
2700, 2800 and 2900  
Tractors

TM1564 (08FEB95) English



**JDI GmbH-ISB**  
**TM1564 (08FEB95)**

LITHO IN U.S.A.  
ENGLISH



**Covers:** 2700,2800,2900

**Type:** Service Manual

**Language:** English

**Pages:** 1120

**Format:** PDF

**Features:** Bookmarked, searchable, printable

**Compatibility:** Windows/Mac/Tablet/Mobile

This service manual contains important information for the maintenance, troubleshooting and servicing of the **John Deere 2700, 2800, 2900 Tractors All Inclusive Technical Service Manual (tm1564)**

In this manual you will find detailed specifications, illustrations, schematics, diagrams and step-by-step procedures to properly service and diagnose the machine to the manufacturer's standards.

**Contents:**

- General Information
- Specifications
- Serial Number Location
- Engine Specifications
- Engine Diagnostics
- Engine Tests and Adjustments
- Engine Repair
- Power Train
- Transmission
- Axles
- Differential
- PTO
- Hydraulic System
- Electrical System
- Electrical Tests and Diagnostics
- Wiring Diagram / Schematic
- Ignition and Charging
- Steering
- Brakes
- Wheels
- Operator's Platform
- Body Panels
- Disassembly and Assembly
- Diagnostics, Tests and Adjustments
- Troubleshooting
- and much more...

Please note this manual is in **downloadable PDF format only**. If you have any questions about this product or would like to request sample pages, please contact us and reference the product name or SKU.

2. Supporting front of crankcase and sides of front bearing (A), install front of crankshaft to front bearing. Press crankshaft (B) through bearing until bearing seats to shoulder of crankshaft.

*NOTE: Make sure ID of front bearing is not supported on press.*

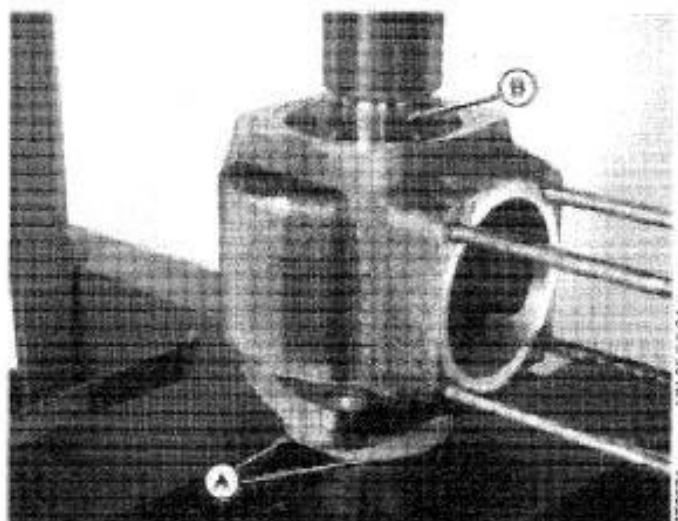

TM1564,2055,AE -19-08FEB95

3. With front bearing being supported to press, install rear bearing (A) onto crankshaft and crankcase. Press rear bearing until it is flush with the crankshaft (B).

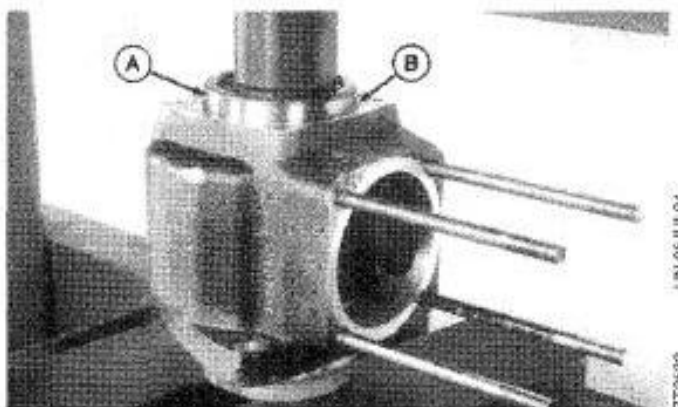

TM1564,2055,AF -19-08FEB95

4. Turn crankcase over and support rear bearing and crankcase (A) to press. Press front bearing (B) to shoulder of crankcase using a 27 mm deep well socket (C).



TM1564,2055,AG -19-08FEB95

**DISASSEMBLE ALTERNATOR**

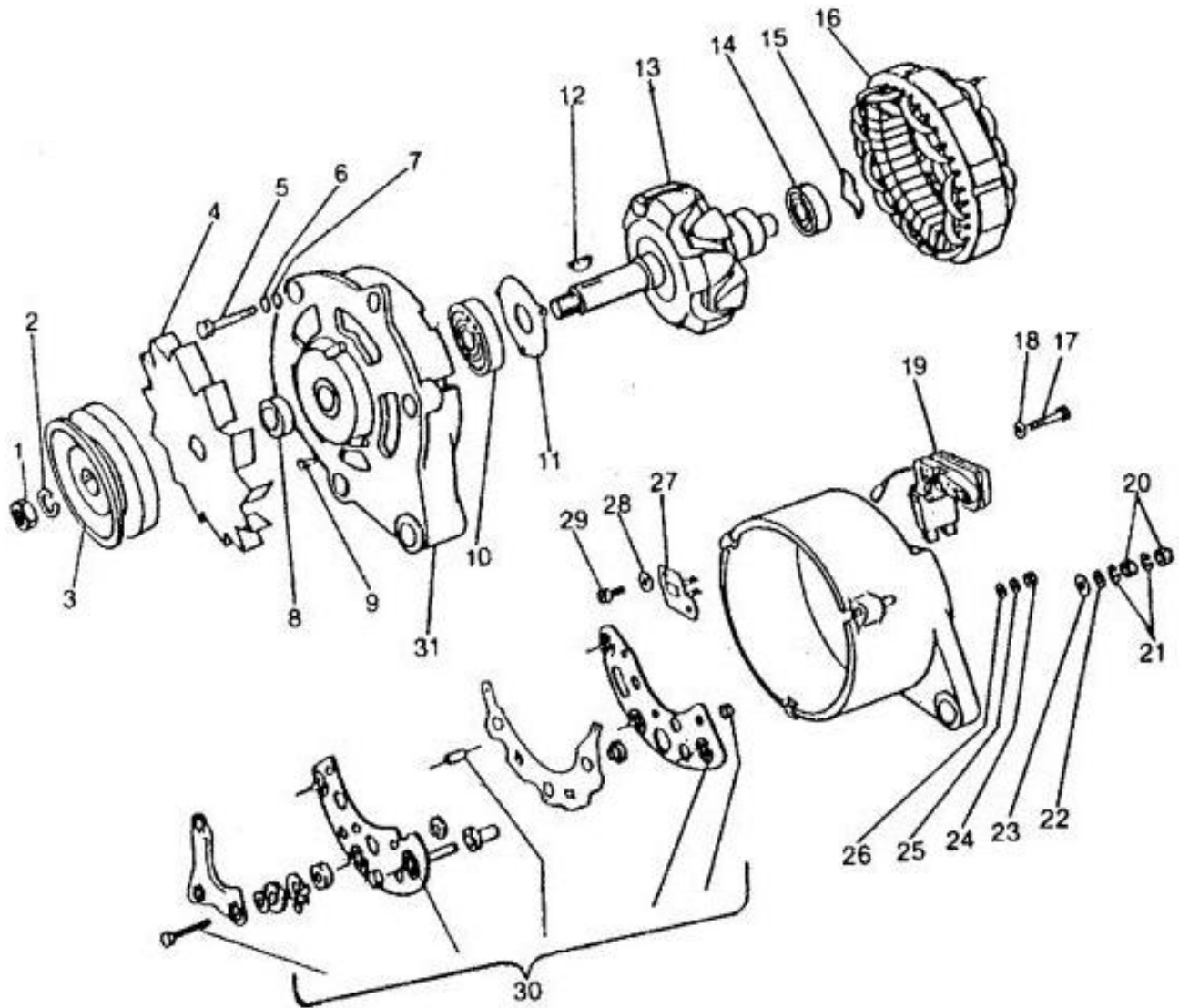

- 1—Nut, M14 x 1.5
- 2—Lock Washer
- 3—Pulley
- 4—Fan
- 5—Bolt, M5 x 60
- 6—Lock Washer
- 7—Flat Washer
- 8—Spacer

- 9—Rivet
- 10—Front Bearing
- 11—Bearing Plate
- 12—Shaft Key
- 13—Rotor
- 14—Rear Bearing
- 15—Ring
- 16—Stator

- 17—Bolt, M5 x 18
- 18—Washer
- 19—Brush/Regulator Assembly
- 20—Nut, M6
- 21—Lock Washer
- 22—Flat Washer
- 23—Insulated Washer

- 24—Nut, M5
- 25—Lock Washer
- 26—Flat Washer
- 27—Field Terminal
- 28—Washer
- 29—Screw, M4 x 10
- 30—Rectifier Bridge Assembly

40  
25  
7

UNIONTECH  
270811



Thank you very much  
for your reading.  
Please click here  
to get more information.