

John Deere 3754D Road Builder Diagnostic, Operation and Test Service Manual (TM10334)

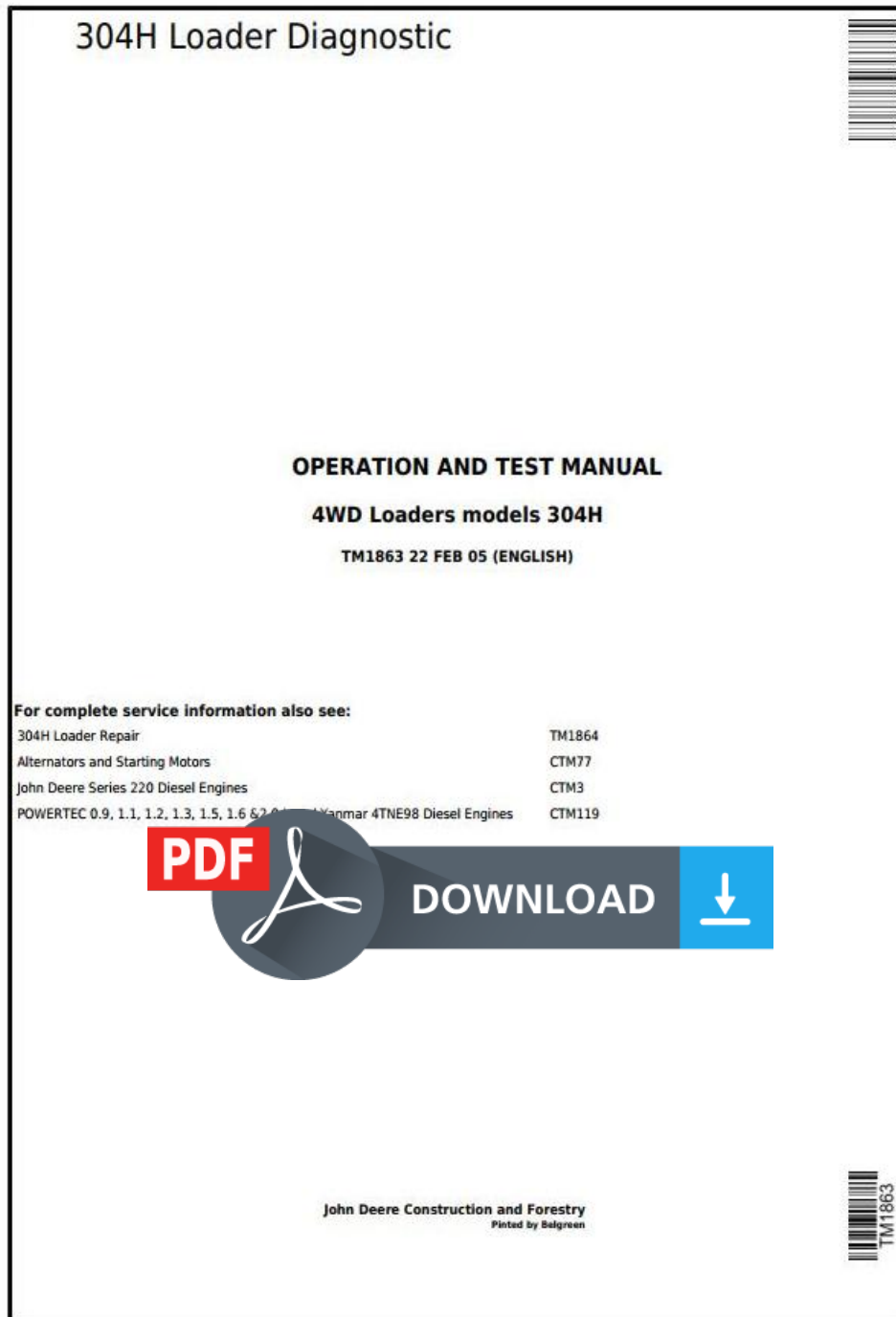

Covers: 3754D

Type: Service Manual

Language: English

Pages: 818

Format: PDF

Features: Bookmarked, searchable, printable

Compatibility: Windows/Mac/Tablet/Mobile

This service manual contains important information for the maintenance, troubleshooting and servicing of the **John Deere 3754D Road Builder Diagnostic, Operation and Test Service Manual (TM10334)**

In this manual you will find detailed specifications, illustrations, schematics, diagrams and step-by-step procedures to properly service and diagnose the machine to the manufacturer's standards.

Contents:

- General Information
- Specifications
- Serial Number Location
- Engine Specifications
- Engine Diagnostics
- Engine Tests and Adjustments
- Engine Repair
- Power Train
- Transmission
- Axles
- Differential
- PTO
- Hydraulic System
- Electrical System
- Electrical Tests and Diagnostics
- Wiring Diagram / Schematic
- Ignition and Charging
- Steering
- Brakes
- Wheels
- Operator's Platform
- Body Panels
- Disassembly and Assembly
- Diagnostics, Tests and Adjustments
- Troubleshooting
- and much more...

Please note this manual is in **downloadable PDF format only**. If you have any questions about this product or would like to request sample pages, please contact us and reference the product name or SKU.

Group 05 - Theory Of Operation

Power Train Description

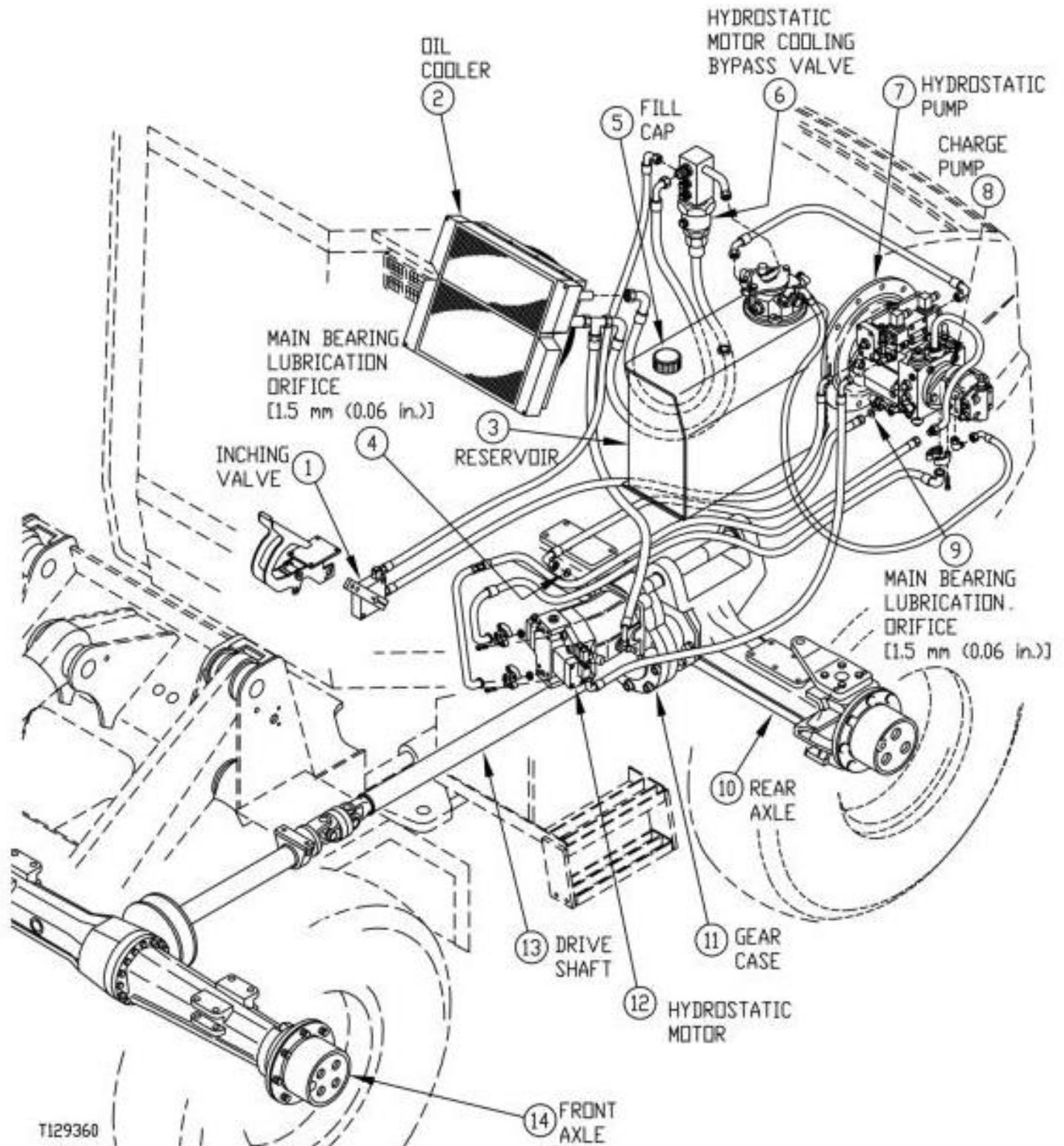

Power Train Components

LEGEND:

- 1 Inching Valve
- 2 Oil Cooler

Hydrostatic Pump Control Operation-Reverse (Engine Speed At Less Than Fast Idle)

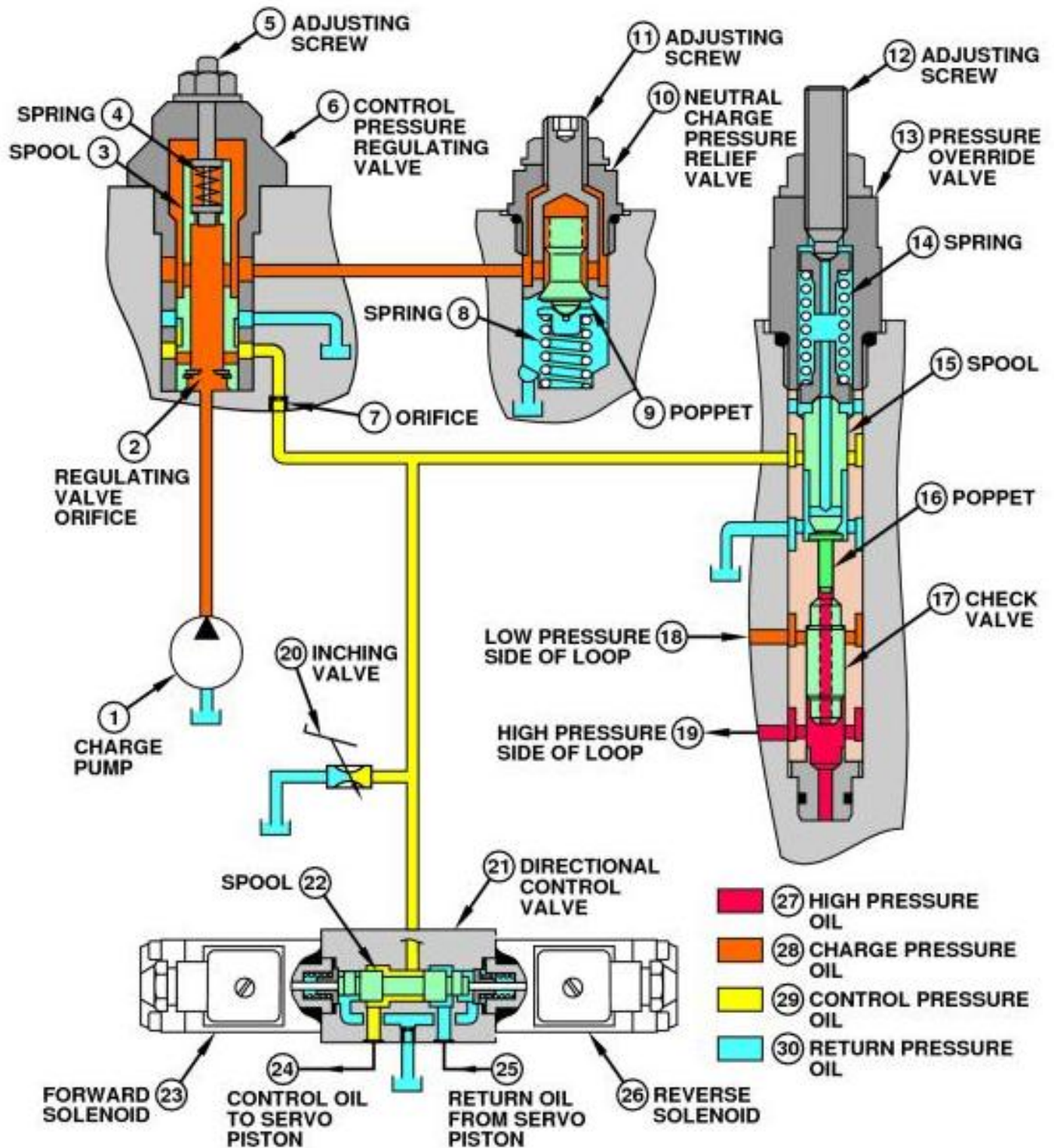

T113286

Hydrostatic Pump Control Circuit

LEGEND:

- 1 Charge Pump
- 2 Regulating Valve Orifice



Thank you very much
for your reading.
Please click here
to get more information.