

John Deere 444K w.Engine 4045HDW54 (T3) 4WD Loader (SN.before 642100) Service Repair Manual (TM10685)

225DLC Excavator Diagnostic

OPERATION AND TEST MANUAL

225DLC

TM10082 24FEB15 (ENGLISH)

For complete service information also see:

225DLC Excavator Repair	TM10085
Super Caddy Oil Cleanup Procedure	CTM310
JDLINK/ZXLINK Machine Monitoring System	CTM10006
JDG10274 Ultrasonic Undercarriage Measurement Gauge	CTM10001



John Deere Construction and Forestry

Covers: 444K,642100)

Type: Service Manual

Language: English

Pages: 532

Format: PDF

Features: Bookmarked, searchable, printable

Compatibility: Windows/Mac/Tablet/Mobile

This service manual contains important information for the maintenance, troubleshooting and servicing of the **John Deere 444K w.Engine 4045HDW54 (T3) 4WD Loader (SN.before 642100) Service Repair Manual (TM10685)**

In this manual you will find detailed specifications, illustrations, schematics, diagrams and step-by-step procedures to properly service and diagnose the machine to the manufacturer's standards.

Contents:

- General Information
- Specifications
- Serial Number Location
- Engine Specifications
- Engine Diagnostics
- Engine Tests and Adjustments
- Engine Repair
- Power Train
- Transmission
- Axles
- Differential
- PTO
- Hydraulic System
- Electrical System
- Electrical Tests and Diagnostics
- Wiring Diagram / Schematic
- Ignition and Charging
- Steering
- Brakes
- Wheels
- Operator's Platform
- Body Panels
- Disassembly and Assembly
- Diagnostics, Tests and Adjustments
- Troubleshooting
- and much more...

Please note this manual is in **downloadable PDF format only**. If you have any questions about this product or would like to request sample pages, please contact us and reference the product name or SKU.

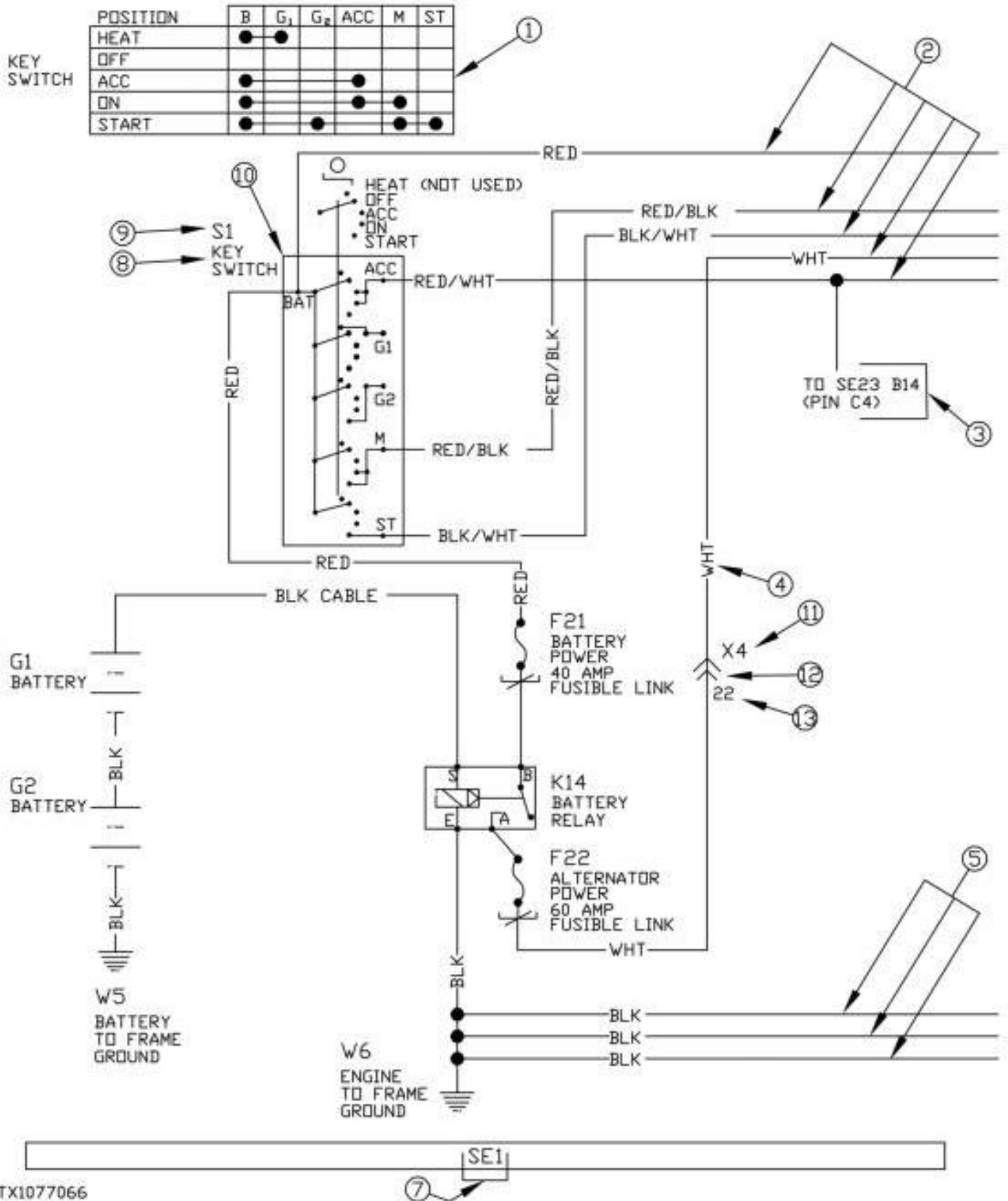

System Functional Schematic Example

LEGEND:

- 1 Continuity Chart
- 2 Power Wires
- 3 Routing Location Information
- 4 Wire Identification
- 5 Ground Wires

Travel Pilot Control Valve Operation

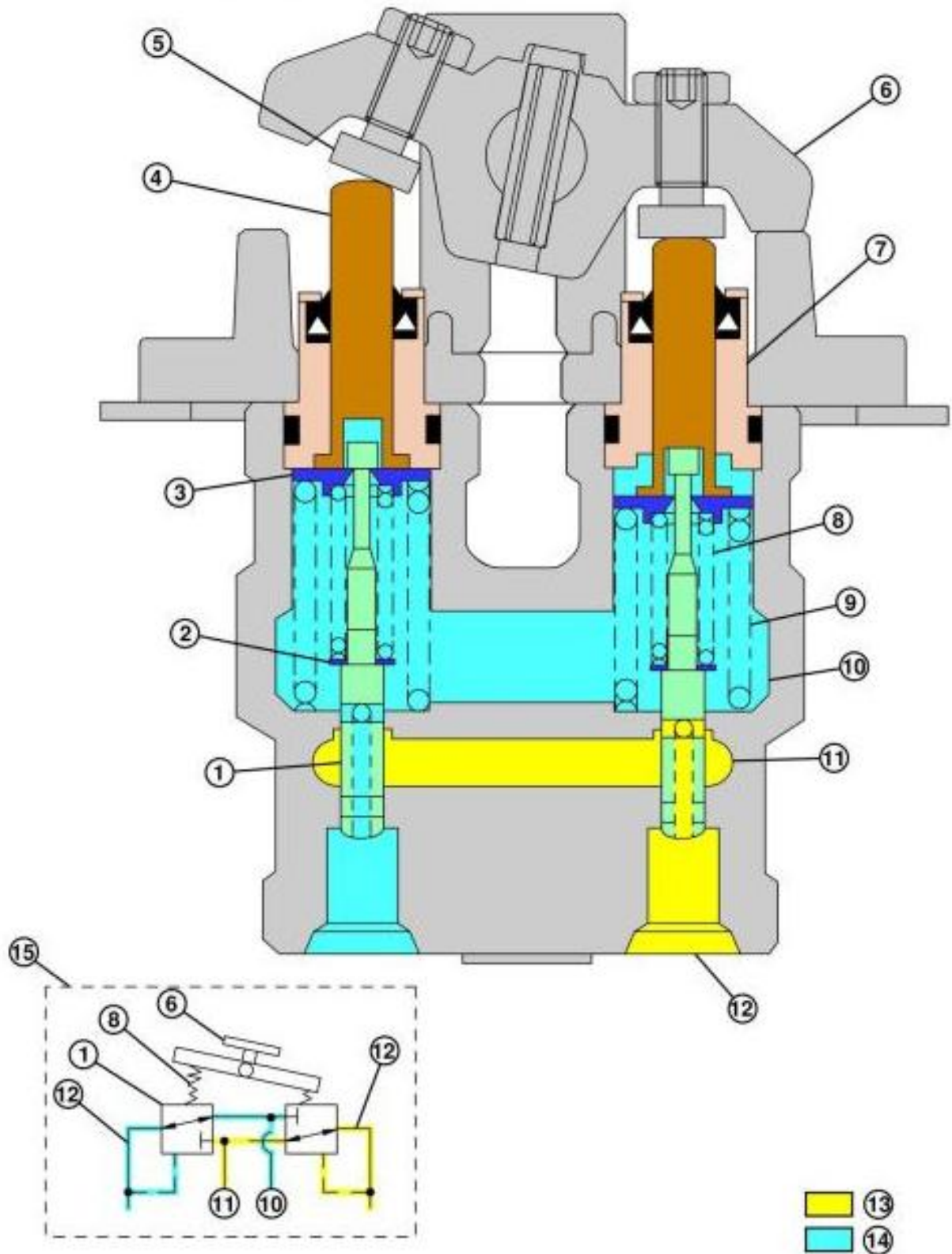

TX1000485

Travel Pilot Control Valve

LEGEND:

- 1 Spool
- 2 Washer
- 3 Spring Guide



Thank you very much
for your reading.
Please click here
to get more information.