

# John Deere 6100B and 6110B China Tractors Service Repair Manual (TM700819)

**6100B and 6110B  
Tractors TM - All  
Inclusive**

**TECHNICAL MANUAL**

**2WD or MFWD - China models 6100B, 6110B**

**TM700819 21JAN13 (ENGLISH)**



John Deere Agriculture

**Covers:** 6100B,6110B

**Type:** Service Manual

**Language:** English

**Pages:** 1286

**Format:** PDF

**Features:** Bookmarked, searchable, printable

**Compatibility:** Windows/Mac/Tablet/Mobile

This service manual contains important information for the maintenance, troubleshooting and servicing of the **John Deere 6100B and 6110B China Tractors Service Repair Manual (TM700819)**

In this manual you will find detailed specifications, illustrations, schematics, diagrams and step-by-step procedures to properly service and diagnose the machine to the manufacturer's standards.

**Contents:**

- General Information
- Specifications
- Serial Number Location
- Engine Specifications
- Engine Diagnostics
- Engine Tests and Adjustments
- Engine Repair
- Power Train
- Transmission
- Axles
- Differential
- PTO
- Hydraulic System
- Electrical System
- Electrical Tests and Diagnostics
- Wiring Diagram / Schematic
- Ignition and Charging
- Steering
- Brakes
- Wheels
- Operator's Platform
- Body Panels
- Disassembly and Assembly
- Diagnostics, Tests and Adjustments
- Troubleshooting
- and much more...

Please note this manual is in **downloadable PDF format only**. If you have any questions about this product or would like to request sample pages, please contact us and reference the product name or SKU.

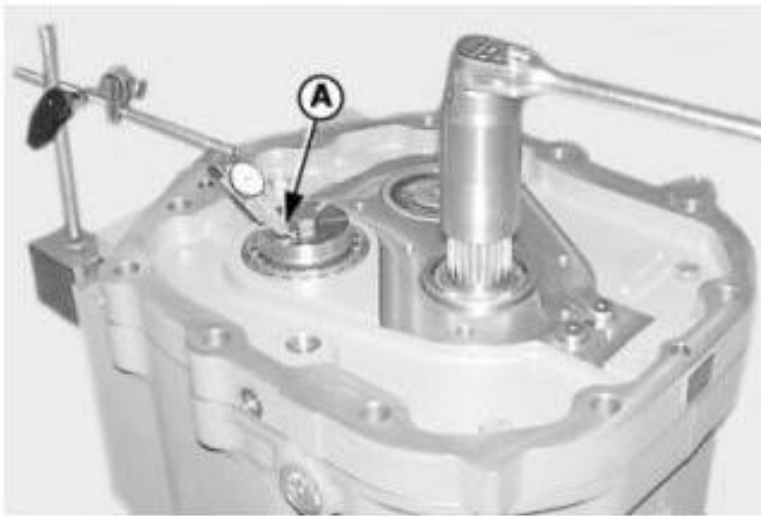

f.

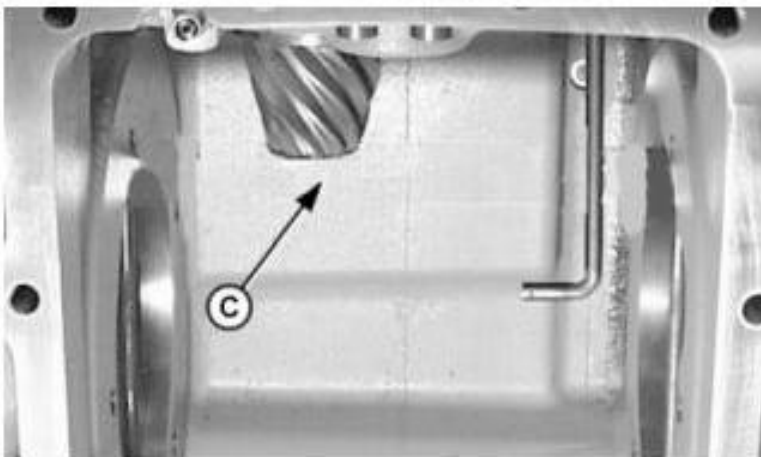
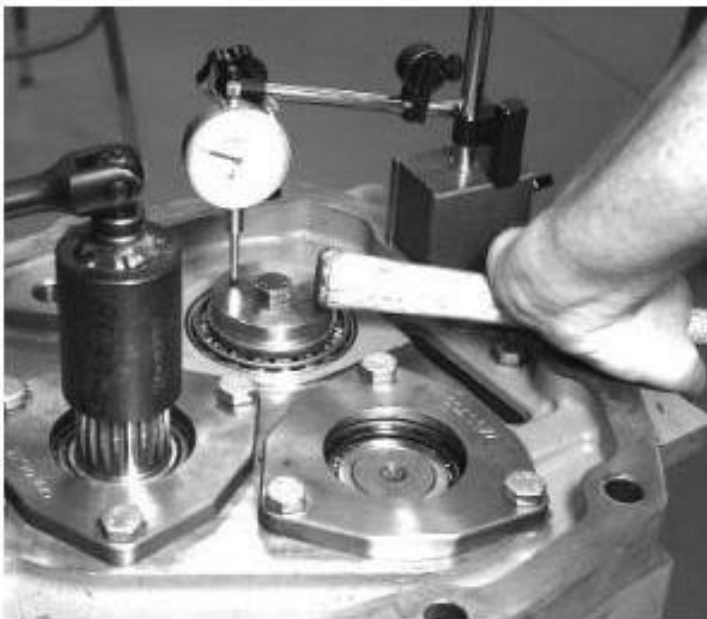
**LEGEND:**

- A Dial Indicator
- B Splined Socket
- C End of Spiral Bevel Gear

Install dial indicator (A). Install JDG1398 Splined Socket (B) to input shaft and rotate five

## Install Front Axle - MFWD

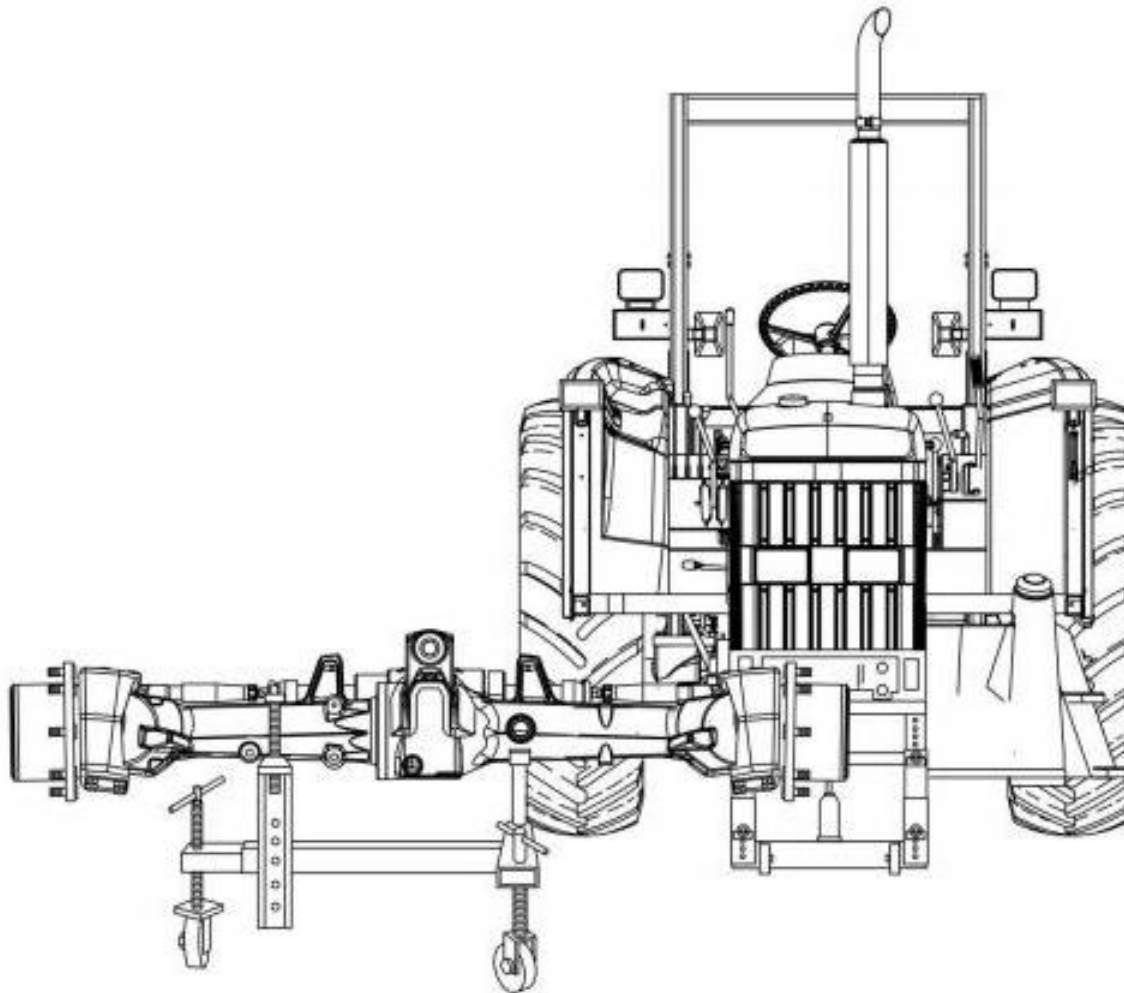

**[1]** - Raise tractor and support safely using JT05725 Universal Support Stand and/or a suitable lifting device.

Universal Support Stand

JT05725

Used to jack front of tractor while servicing axle.

**[2]** - Install D05007ST Rear Tractor Splitting Stand, together with Short Adapter (See DEALER FABRICATED TOOLS in Section 99) and one T25671 Adapter Plate to the front axle.

Rear Tractor Splitting Stand

D05007ST

To support front axle during removal.

Adapter Plate

T25671

[ Can be dealer fabricated. See Section 99 for instructions to make tool. ]

Used in conjunction with tools D05007ST to support front axle.

Short Adapter

Used in conjunction with D05007ST to support front axle.



Thank you very much  
for your reading.  
Please click here  
to get more information.