

John Deere 624K 4WD Loader (SN.642635-658064) w.Engine 6068HDW78 Diagnostic Service Manual (TM12101)

3050, 3350 and
3650 Tractors



John Deere Werke Mannheim
TM4443 (Nov-90)
PRINTED IN GERMANY
ENGLISH

Covers: 624K,1DW624KZ**E642635-658064)

Type: Service Manual

Language: English

Pages: 1518

Format: PDF

Features: Bookmarked, searchable, printable

Compatibility: Windows/Mac/Tablet/Mobile

This service manual contains important information for the maintenance, troubleshooting and servicing of the **John Deere 624K 4WD Loader (SN.642635-658064) w.Engine 6068HDW78 Diagnostic Service Manual (TM12101)**

In this manual you will find detailed specifications, illustrations, schematics, diagrams and step-by-step procedures to properly service and diagnose the machine to the manufacturer's standards.

Contents:

- General Information
- Specifications
- Serial Number Location
- Engine Specifications
- Engine Diagnostics
- Engine Tests and Adjustments
- Engine Repair
- Power Train
- Transmission
- Axles
- Differential
- PTO
- Hydraulic System
- Electrical System
- Electrical Tests and Diagnostics
- Wiring Diagram / Schematic
- Ignition and Charging
- Steering
- Brakes
- Wheels
- Operator's Platform
- Body Panels
- Disassembly and Assembly
- Diagnostics, Tests and Adjustments
- Troubleshooting
- and much more...

Please note this manual is in **downloadable PDF format only**. If you have any questions about this product or would like to request sample pages, please contact us and reference the product name or SKU.

DISASSEMBLING COMPRESSOR

Removing Dust Cap

Remove six attaching screws (A) and lift off dust cap (B).



Z103855-Z129015AE-001084

Removing Clutch Hub

1. Hold drive belt pulley with holding strap JDG217 and remove hex. nut from shaft.

2. Screw part (A) of puller JDG216 into belt pulley. Use screw (B) of puller JDG216 to force clutch hub out of pulley.

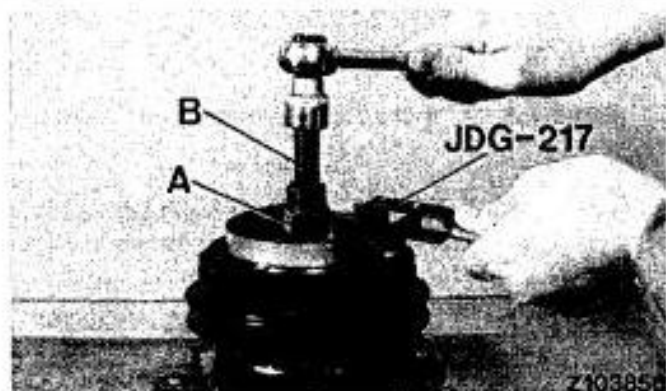

Z103856-Z129015AE-001084

Removing Drive Plate

1. Remove spacers (A) and note number of spacers used for assembly.

2. Remove snap ring (B) and key (C).

3. Pull off drive plate, using thrust piece JDG220 (D) and puller.



A-Spacer
B-Snap ring
C-Drive key
D-Thrust piece JDG220

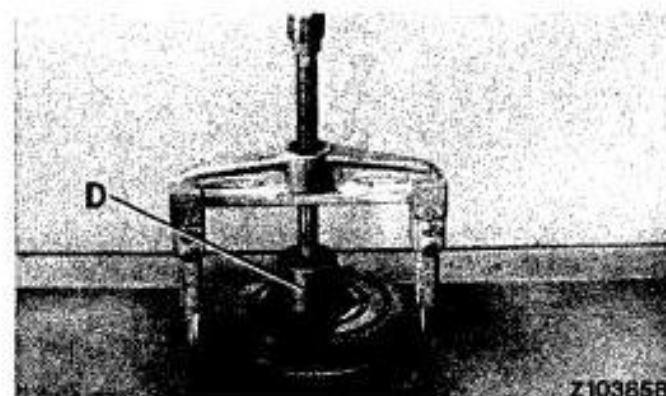

Z103857,Z103858-Z129015AE-001084

HI-LO SHIFT UNIT, SECTIONAL VIEW
 (Tractors 3050 and 3350 up to 40 km/h; 25 mph and 3650)

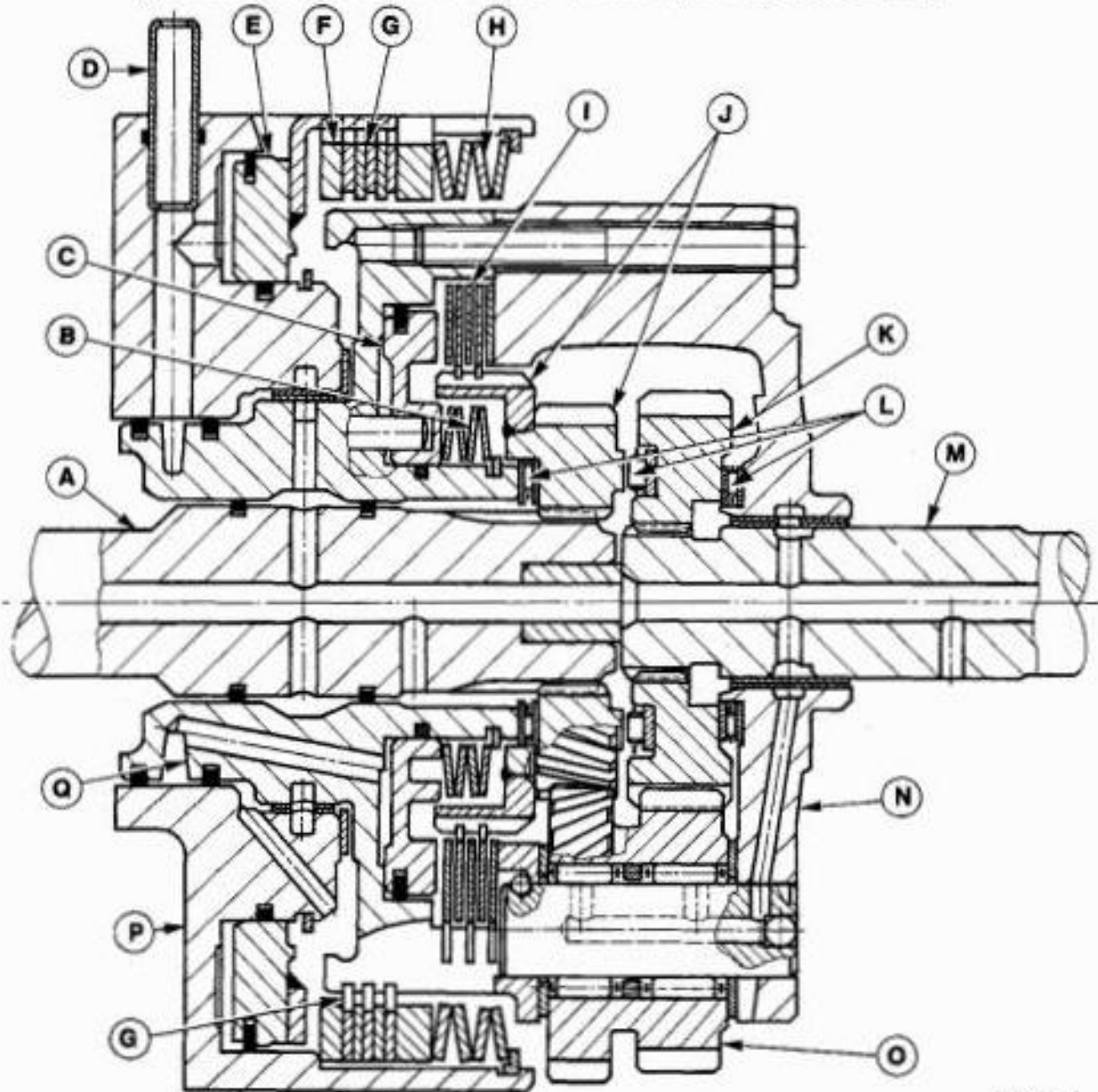

L 108 075

A-Transmission input shaft
 B-Hi-clutch Belleville springs
 C-Hi-clutch piston
 D-Pressure oil passage to Hi-clutch
 and Lo-brake piston
 E-Lo-brake piston

F-External splined brake disks
 G-Internal splined brake disks
 H-Lo-brake Belleville springs
 I-External splined clutch disks
 J-Sun gear with clutch hub
 K-Sun gear

L-Thrust bearing
 M-Solid drive shaft
 N-Planet pinion carrier
 O-Planet gear (3 used)
 P-Brake housing
 Q-Clutch drum

L108075-LB25015AE-010896



Thank you very much
for your reading.
Please click here
to get more information.