

John Deere Sabre 1642HS, 14.542GS, 17.542HS, 1442GS Lawn Tractors Technical Service Manual (tm1948)

724K 4WD Loaders with
Engines 6090HDW13
Repair



REPAIR TECHNICAL MANUAL

4WD Loaders models 724K (PIN: 1DW724KZE634315-658064)**

TM12111 16 FEB 16 (ENGLISH)

For complete service information also see:

| | |
|----------------------------------------------------|-----------|
| 724K 4WD Loaders with Engines 6090HDW13 Diagnostic | TM12109 |
| JDLink (MTG) Technical Manual | TM114519 |
| TMIV1200 - 1400 Series Inboard Planetary Axles | CTM442 |
| 120 Series Hydraulic Cylinders | CTM120519 |
| 185 Series Hydraulic Cylinders | CTM114919 |
| 120 Series Hydraulic Cylinders | |
| 125 Series Hydraulic Cylinders | |
| 6090 PowerTech Diesel Engine | |
| JDLink/ZXLink Machine Monitor | |

PDF  **DOWNLOAD** 

John Deere Construction and Forestry
Printed by Belgreen



TM12111

Covers: 1442GS,1642HS,14.542GS,17.542HS

Type: Service Manual

Language: English

Pages: 260

Format: PDF

Features: Bookmarked, searchable, printable

Compatibility: Windows/Mac/Tablet/Mobile

This service manual contains important information for the maintenance, troubleshooting and servicing of the **John Deere Sabre 1642HS, 14.542GS, 17.542HS, 1442GS Lawn Tractors Technical Service Manual (tm1948)**

In this manual you will find detailed specifications, illustrations, schematics, diagrams and step-by-step procedures to properly service and diagnose the machine to the manufacturer's standards.

Contents:

- General Information
- Specifications
- Serial Number Location
- Engine Specifications
- Engine Diagnostics
- Engine Tests and Adjustments
- Engine Repair
- Power Train
- Transmission
- Axles
- Differential
- PTO
- Hydraulic System
- Electrical System
- Electrical Tests and Diagnostics
- Wiring Diagram / Schematic
- Ignition and Charging
- Steering
- Brakes
- Wheels
- Operator's Platform
- Body Panels
- Disassembly and Assembly
- Diagnostics, Tests and Adjustments
- Troubleshooting
- and much more...

Please note this manual is in **downloadable PDF format only**. If you have any questions about this product or would like to request sample pages, please contact us and reference the product name or SKU.

Clutches and Input and Output Shafts Remove

Essential Tools

ESSENTIAL TOOLS

JDG1129A Transmission Mounting Brackets

[1] -



Remove Output Flange from Shaft

Remove front and rear output flange from output shafts.

[2] - Remove output shaft seals from housing bores.

[3] -

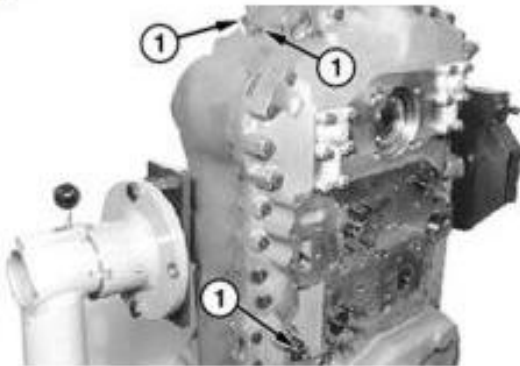

LEGEND:

1 Sensor (3 used)

Sensor Location

Remove torque converter input speed sensor, internal clutch speed sensor, and torque converter output speed sensor.

[4] -

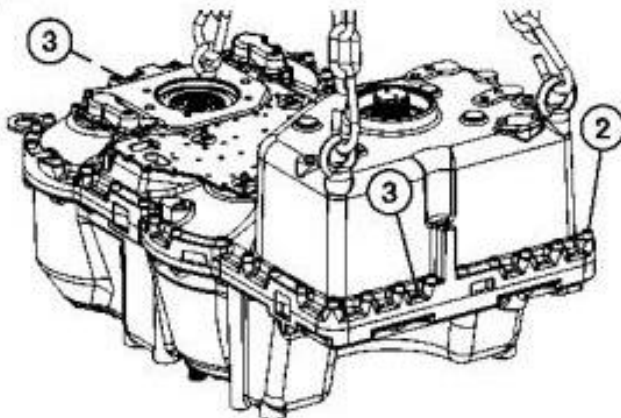

LEGEND:

2 Cap Screw
3 Dowel Pin (2 used)

Cap Screws and Dowel Pins

Remove cap screws (2) from transmission cover

[5] - Drive both dowel pins (3) down far enough to clear cover for removal.

[6] -

Engine Remove and Install

Specifications

| SPECIFICATIONS | |
|----------------------------------|----------------------|
| Engine Weight (approximate) | 1173 kg 2585 lb. |
| Engine Mount Cap Screw Torque | 522 N·m 384 lb·ft |
| Universal Joint Cap Screw Torque | 78 N·m 58 lb·ft |

Essential Tools

| ESSENTIAL TOOLS |
|----------------------------------|
| JDG11256 Lifting Bracket (rear) |
| JDG11252 Lifting Bracket (front) |

Service Equipment and Tools

| SERVICE EQUIPMENT AND TOOLS |
|-----------------------------|
| JDG23 Lifting Sling |

[1] - Prepare machine for service. [See Park and Prepare for Service Safely](#). (Group 0001.)

[2] -



CAUTION:

To avoid injury from escaping fluid under pressure, stop engine and relieve the pressure in the system before disconnecting or connecting hydraulic or other lines. Tighten all connections before applying pressure.

Relieve hydraulic system pressure. [See Hydraulic System Pressure and Accumulators Discharge](#). (Group 9025-25.)

[3] - Remove radiator. [See Radiator Remove and Install](#). (Group 0510.)

[4] -

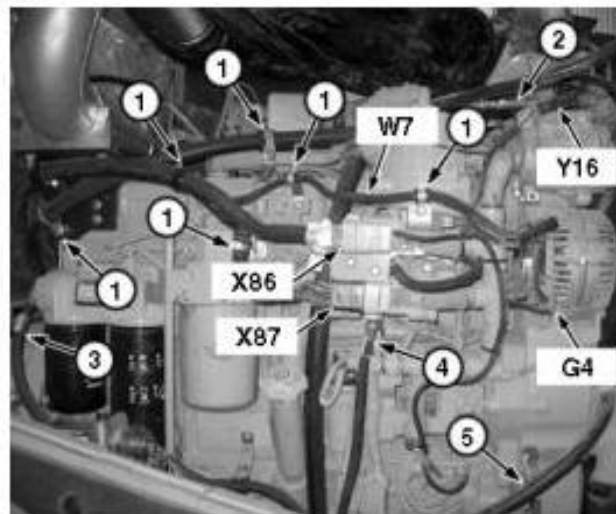

LEGEND:

- 1 Clamp (6 used)
- 2 Air Conditioner Expansion Valve-to-Compressor Line
- 3 Fuel Tank-to-Fuel Transfer Pump Line
- 4 Fuel Return-to-Fuel Cooler Line
- 5 Engine Block-to-Heater Core Line
- G4 Alternator
- W7 Engine Interface Harness
- X86 Engine Interface Harness-to-Engine Harness 40-Pin Connector
- X87 Engine Interface Harness-to-Engine Harness 40-Pin Connector
- Y16 Air Conditioner Compressor Clutch Solenoid

Engine (left side shown)

Disconnect air conditioner compressor clutch solenoid (Y16) electrical connector and alternator (G4) from engine interface harness (W7). [See Engine Interface Harness \(W7\) Component Location](#). (Group 9015-10.)

[5] - Disconnect engine interface harness-to-engine harness electrical connectors (X86 and X87) and remove engine interface harness from engine. [See Engine Interface Harness \(W7\) Component Location](#). (Group 9015-10.)



Thank you very much
for your reading.
Please click here
to get more information.